

AQR253...

AQR257...

Symaro™

Flush-mount room sensor **AQR253...** KNX S-Mode / KNX LTE- **AQR257...** Mode / KNX PL-Link

- Communicating room sensor with KNX S-Mode, KNX LTE-Mode and KNX PL-Link for Desigo™ Total Room Automation
- Combinable multi-sensor to measure temperature, humidity, and CO₂ concentration
- Range 0...+50 °C / 0...95 % r.h. (non-condensing) / 0...5000 ppm
- Air quality indication via LED
- PID room temperature controller and ventilation controller (KNX S-Mode)
- 2 binary inputs for potential-free contacts
- Input for additional, remote passive temperature sensor (NTC 10k)
- Optimized, energy-saving measuring methods ideal for energy-efficient room applications
- Supplied via bus
- Maintenance free

Use

The room sensor is used in heating, ventilating and air conditioning plants to optimize comfort and energy consumption via demand-controlled ventilation.

The room sensor records:

- CO₂ concentration in rooms with varying occupancy due to time or number of people such as in museums, movie theaters, offices, meeting rooms, class rooms, auditoriums, hospitals, living spaces.
- Relative room humidity.
- Room temperature.
- A second room temperature for averaging, or floor or ceiling temperature.

The room sensor helps to control:

- Room temperature via PID controller.
- Air quality:
- Humidity.

As well as

- Switching of electrical devices
- Switching and dimming lights
- Control solar protection systems.
- Monitor window contacts.

Note

Devices featuring CO₂ measurement are not suited to safety applications such as gas or smoke alarm.

Type summary, ordering

An installed sensor comprises front module, base module with mounting plate as well as separate-order design frame (see "Accessories"). Both front and base module can be combined as needed:

Front module

<i>Product number</i>	<i>Stock number</i>	<i>Humidity measuring range</i>	<i>Temperature measuring range</i>	<i>Air quality indication</i>
AQR2530NNW	S55720-S137	–	–	–
AQR2532NNW	S55720-S136	–	0...50 °C	–
AQR2533NNW	S55720-S140	0...100 % r.h.	–	–
AQR2535NNW	S55720-S141	0...100 % r.h.	0...50 °C	–
AQR2535NNWQ	S55720-S219	0...100 % r.h.	0...50 °C	LED

Base module

<i>Product number</i>	<i>Stock number</i>	<i>CO₂ measuring range¹⁾</i>	<i>Format</i>	<i>Dimensions [mm]</i>
AQR2570NF	S55720-S203	–	CEE/VDE	70.8 x 70.8
AQR2570NH	S55720-S204	–	British Std	83 x 83
AQR2570NG	S55720-S205	–	3 Modular	110 x 64
AQR2570NJ	S55720-S206	–	UL	64 x 110
AQR2576NF	S55720-S207	0...5000 ppm	CEE/VDE	70.8 x 70.8
AQR2576NH	S55720-S208	0...5000 ppm	British Std	83 x 83
AQR2576NG	S55720-S209	0...5000 ppm	3 Modular	110 x 64
AQR2576NJ	S55720-S210	0...5000 ppm	UL	64 x 110

All base modules have one input for a remote NTC 10k temperature sensor as well as connections for 2 potential-free contacts to operate lighting and solar protection systems.

1) ppm = Parts per million

Accessories

Siemens Design frames

<i>Type (ASN)</i>	<i>Stock number (SSN)</i>	<i>Frame designation (color)</i>	<i>Format</i>	<i>Dimensions [mm]</i>
AQR2510NFW	S55720-S158	DELTA line (titanium white)	CEE/VDE	80 x 80
AQR2510NHW	S55720-S159	DELTA miro (titanium white)	British Standard	90 x 90
AQR2510NGW	S55720-S160	DELTA azio (titanium white)	3 Modular UL	120 x 80 80 x 120

See "Dimensions" for design frame dimensions.

Third-party design frames

The sensor can be combined with the design frames from the following third manufacturers:

<i>Manufacturer</i>	<i>Product number</i>
Siemens DELTA	DELTA line, DELTA miro, DELTA vita, DELTA profil (with adapter frame for inserts 55 mm x 55 mm)
Berker	B.1, B.7
Feller	EDIZIOdue PRESTIGE (with adapter frame for inserts 55 mm x 55 mm)
Gira	E2, Event
Jung	Ap581, A500, AS500
Merten	System M

We recommend comparing the frame dimensions of third-party frames to the dimensions listed in section "Dimensions".

Sensors and room operator units

The following temperature sensors can be used to record a second temperature as an option. The double pushbutton listed below can be connected to the binary inputs.

<i>Designation</i>	<i>Type</i>	<i>Data sheet</i>
Flush-mount temperature sensor *	AQR2531FNW	1408
Outside sensor	QAC2030	1811
Strap-on temperature sensor	QAD2030	1801
Duct temperature sensor	QAM2130.040	1761
Duct temperature sensor	QAP1030.200	1831
DELTA pushbutton, double	5TD2 111	

* Use with mounting plate as per the regionally common format
See "Mounting plates and design frames" on page 12.

Equipment combinations

The room sensors are KNX certified and can be connected to all suitable devices with KNX, provided the corresponding data points are available.

The room sensors can be used with the following building automation and control systems:

- Desigo TRA V5.1 (KNX PL-Link)
- Synco 700 (KNX LTE-Mode)
- GAMMA Building Management Systems / third-party devices (KNX S-Mode)

Controllers and actuators	Type	Data sheet
KNX PL-Link compact controller	PXC3..	9203
Synco 7... controller	RMS705 / RMK770	3123 / 3132
Synco living central apartment unit	QAX903 / QAX913...	2741 / 2740
Controller (KNX S-Mode)	RXB2x.1..., RXL2x.1	3873 / 3874 / 3877
Climatix controller	POL63x.00 / POL68x.xx	3230 / 3903
Fan coil control, 3-stage	5WG15621AB11	see www.siemens.com/gamma
Motorized valve actuator	5WG15627AB02	
Electrothermal valve actuator	5WG16051AB01, 5WG16051AB11	

Configuration and service tools

USB-KNX interface	OCI700.1	5655
Tool connection cable	RXZ11.1	

Functions

The room sensor allows for measuring the room temperature, relative humidity, and CO₂ concentration in the room. An additional, passive temperature sensor can be connected to measure another temperature. The binary inputs of the room sensor detect the status of up to two connectable, potential-free contacts. As a result, up to four measured values and two states can be transmitted to other members of the building automation and control system via the common KNX bus interface.

Integrated control functions for room temperature and ventilation allow for immediate control of suitable actors to control heating, cooling, and ventilation.

Temperature (AQR2532..., AQR2535...)

The room sensor measures the room temperature via an integrated sensing element. The room temperature serves as control variable of the integrated room temperature controller and can be transmitted to other bus members. If an additional, passive room temperature sensor is connected to the base module, the second measured room temperature can be averaged with the internally measured room temperature.

(AQR257...)

Each base module has an input for a passive NTC 10k sensing element. The measured temperature can be transmitted to the bus members depending on the selected sensor type as either a room temperature weighted at 100%: 0% to 0% (ext.: int) 100% or as a universal temperature, e.g. floor or ceiling temperature.

Relative humidity (AQR2533..., AQR2535...)

The room sensor acquires the relative humidity in the room with the aid of a humidity sensing element integrated in the front module. The relative room humidity serves as control variable of the integrated ventilation controller and can be transmitted to other bus members.

CO₂ concentration (AQR2576...)

The room sensor determines the CO₂ concentration via infrared absorption measurement (NDIR). The sensor provides exact measurements at all times and does not require maintenance or recalibration thanks to an integrated, stable reference light source. The CO₂ concentration serves as control variable of the integrated ventilation controller and can be transmitted to other bus members.

Air quality indication



(AQR2535...Q)

The background-lit symbol informs on the current level of CO₂ in the room. The colors **green** / **orange** / **red** of the background lighting indicate **good** / **mediocre** / **poor** air quality. The display can be switched on or off via communication object, e.g. switch or timer.

Binary inputs

(AQR257...)

The room sensor acquires the states of up to two potential-free contacts. The two inputs can be parameterized freely to switch and dim lighting as well as control solar protection plants via suitable actors. At the same time, window contacts, for example, can also be monitored. The states are transmitted to other bus members.

Control functions

(AQR257...,
KNX S-Mode)

The room sensors can be connected to suitable heating, ventilating, and air conditioning actors with KNX S-Mode via integrated control functions for room temperature, humidity, and air quality.

A proven PID controller for heating and cooling in KNX S-Mode is provided to control the room temperature.

The integrated room humidity controller and room air quality controller can be used for ventilation control.

Design

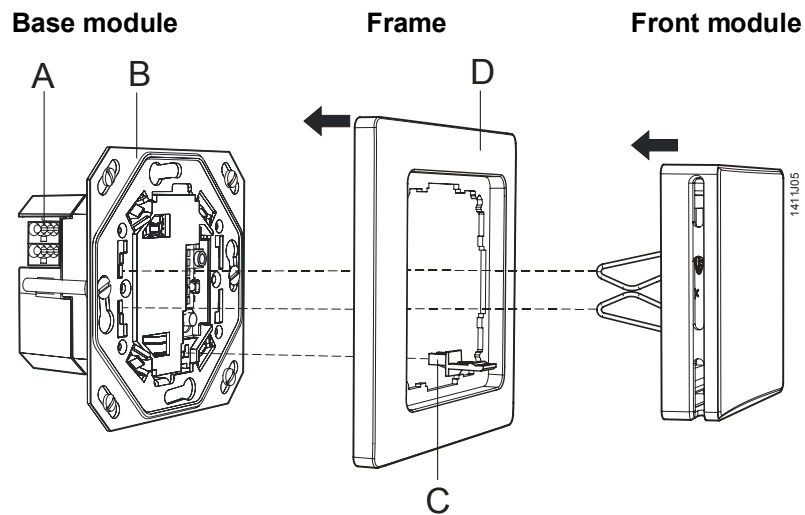

- A KNX bus connection terminal
- B Mounting plate
- C Anti-theft device
- D Design frame

The room sensor comprises:

- One base module with snapped-on mounting plate.
- One design frame (ordered as separate accessory) and
- One front module.

The sensing elements are located in either the base or the front module (see "Type summary").

Engineering notes

Detailed product documentation

For detailed information on engineering, mounting, and commissioning room sensors, see Technical principles CE1P1411en.

Measuring accuracy

Measuring accuracy among other factors depends on the following:

- Prevailing air flow.
- Wall surfaces (rough, smooth).
- Wall texture (wood, plaster, concrete, brick).
- Wall type (interior, exterior).

See also "Mounting notes".

In an installed sensor, measuring inaccuracies are constant after a ca. 1-hour operating time.

Measuring inaccuracies relating to temperature measurements can be corrected as needed.

Mounting and installation notes

Observe the following points when mounting the room sensor:

Mounting location

Sensor mounted on interior wall of room to be conditioned:

- At ca. 1.5 m height in the room and at least 50 cm from the next wall.
- Not on outside walls.
- Not in niches or behind curtains.
- Not above or near heat sources or shelves.
- Not on walls covering heat sources such as a chimney.
- Not in the radiation range of heat sources and lighting bodies e.g. spotlights.
- Not in areas exposed to direct solar radiation.

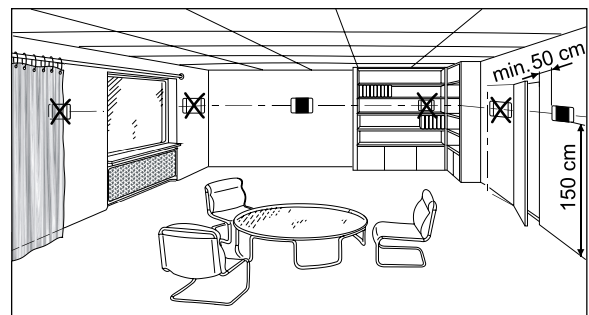

Seal the end of the installation conduit to prevent false measurements due to air drafts.

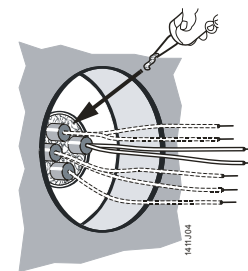

Comply with the various regulations on separating various voltage levels, when mounting the temperature sensor (with extra-low voltage protection) alongside the recessed conduit boxes connected to the low-voltage power. In this case, the mounting frames must be connected to the protective ground wire with a flat plug connector plug designed for grounding.

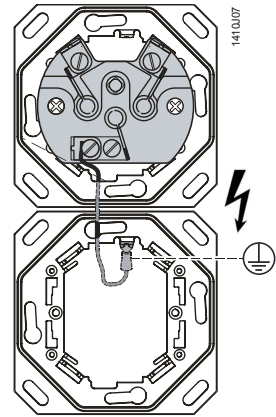

Note the permissible ambient climate (see "Technical data").

Anti-theft device

The front and base module are interconnected via removable snap-on equipment and anti-theft device (red safety plug). Use a screwdriver to easily unlock the anti-theft device. The red safety plug is supplied with the front module.

Mounting instructions

Mounting instructions are enclosed in the device package. Supplementary information on sensor mounting is also available in the following: "Symaro guidelines on sensor mounting" Z-F01040501EN.

Removal

Remove the front module from the base plate, to exchange either front or base module, or to use the tool connection plug.

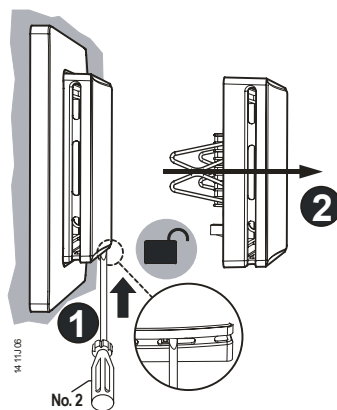

1. Use one hand to unlock the anti-theft device with a screwdriver as needed.
2. Pull out the front module with the other hand.

Installation

The device is designed for flush-mounted cabling. Run the cables from the wall outlet to the sensor base module.

- To cable KNX PL-Link (topology, allowed cables and cable length), read the Designo TRA installation instructions, CM111043.
- Use only suitable, certified cables for the KNX bus.
- Do not swap the wires for the KNX cable.
 - Red terminal is for CE + (KNX+)
 - Gray terminal is for CE - (KNX-)
- Comply with local installation regulations.
- Use a flat plug to connect the ground cable in the plug (same plug in case of switch or mains plug).
- **The device is not protected against inadvertent connection to AC 230 V.**



Caution

Commissioning notes

Service and connection elements

The service elements program button with LED and the tool connection plug as well as the printed KNX ID are available on the base module. The base module contains the measuring switch and connection terminals in addition to service elements (see "Connection terminals").

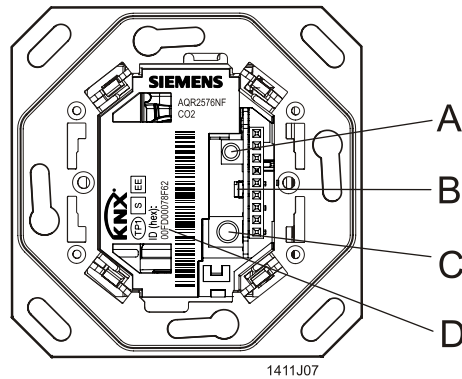

- A Tool connection plug
- B LED status display
- C Programming button
- D KNX ID no.
(hex and barcode)

Commissioning prerequisites

- Prior to commissioning, all devices must be mounted as per mounting instructions M1411 as well as those for the devices to be connected, and connected to voltage supply as well as bus cabling.
- Test both voltage supply and bus cabling.

Recommended commissioning procedure:

- Check the wiring prior to supplying power.
- Install anti-theft protection (red security plug) on the base module as needed.
- Mount the design frame on the mounting plate on the base module and plug in the front module.

Commissioning variants

There commissioning variants are available depending on the system environment:

<i>System/Network environment</i>	<i>Engineering and commissioning tool(s)</i>
KNX PL-Link	Desigo ABT, SSA
KNX LTE-Mode	Synco ACS
KNX S-Mode	ETS3, ETS4

- Basic knowledge of using the tools is prerequisite.
- An interface converter, e.g. OCI700 with tool connection cable RXZ11.1 is required to connect a PC with USB interface to a KNX network.
- Depending on the environment, both type and number of adjustable parameters will vary.

For more information, see basic documentation CE1P1411en.

Response to errors

When combining the front and base module during commissioning, the base module automatically detects the active measure variables of the existing module types.

If a previously unavailable measured variable is parameterized during commissioning, the base module generates an error message.

If an error is present in a sensor module, an error message is output at the corresponding, active sensor object within 10 seconds.

Disposal



The devices are considered electronics devices for disposal in terms of European Directive 2012/19/EU and may not be disposed of as domestic waste.

- Dispose of the device via the channels provided for this purpose.
- Comply with all local and currently applicable laws and regulations.

Technical data

Power	Operational voltage (SELV)	DC 21...29 V, from bus(SELV or class 2 (US))
	Bus load (total, front and base module)	At DC 24 V
	Device without CO ₂ (AQR2570N...) Device with CO ₂ (AQR2576N...)	<5 mA <15 mA
Function data CO ₂ (AQR2576)	Measuring range	0...5000 ppm
	Measuring accuracy at 23 °C and 1013 hPa	≤± (50 ppm +2% of measured value); ≤± (50 ppm +3% of measured value) for measured value >2000 ppm
	Temperature dependency	±2 ppm / °C typical
	Pressure dependency	0.14% of measured value / hPa
	Long-term drift	≤±20 ppm per year
	Time constant t ₆₃	<5 min
	Recalibration-free	For at least 8 years
Function data r.h. (AQR2533, ...34, ...35)	Measuring range	0...100% r.h.
	Field of use	0...95% r.h. (non-condensing)
	Measuring accuracy at 25 °C 20...80% r.h. 0...95% r.h.	±3% r.h. ±5% r.h.
	Time constant	20 s
Function data temperature (AQR2532, ...34 ¹⁾ , ...35 ¹⁾)	Measuring range	0...50 °C
	Measuring accuracy in the range of 25 °C 5...30 °C	<±0.25 K (temperature sensor) <±0.5 K
	Time constant t ₆₃	Ca. 13 min
Function data temperature external (AQR257...)	Sensing elements	Compatible with NTC 10k (B=3988)
	Measuring range	0...50 °C
	Measuring accuracy (without temperature sensor)	<±0.1 K
	Input signal (terminals B, M)	Passive
	Permissible cable length	10 m
Function data binary inputs (AQR257...)	Inputs for potential-free contact	2
	Signal voltage	14...16 V
	Signal current When contact is closed Pulse when closing	0.5 mA 10 mA
	Functions	Parameterizable for: Switch lighting, dim lighting, control blinds, monitor contact, send 8-bit value
Degree of protection	Protection degree of housing	IP30 with front module IP20 without front module according to EN 60529
	Protection class	III according to EN 60730-1
	Electrical connection	Bus connection: Spring terminal Sensor inputs: 4 screw terminals
Environmental conditions	Operation as per Climatic conditions	IEC 60721-3-3 Class 3K3
	Temperature (housing and electronics)	0... 50 °C
	Humidity	0...95% r. h. (non-condensing)
	Mechanical conditions	Class 3M2.

Materials and colors	Transport as per	IEC 60721-3-2
	Climatic conditions	Class 2K3
	Temperature	-25...+70 °C
	Humidity	<95% r.h.
	Mechanical conditions	Class 2M2
	Top part of front module	ASA + PC titanium white (similar to RAL9010).
	Bottom part of front module and housing parts base module	PC light-gray RAL 7035
	Anti-theft device	POM bright red RAL 3000.
Directives and Standards	Siemens Design frames	ASA + PC titanium white (similar to RAL9010).
	Mounting plate	Steel
	Sensor, total	Silicone-free
	Packaging	Corrugated cardboard
	Product standard	EN 60730-1 Automatic electrical controls for household and similar use
		EN 50491-x General requirements for home and building electronic systems (HBES) and building automation and control systems (BACS)
	Electromagnetic compatibility (Applications)	For use in residential, commerce, light-industrial and industrial environments
	EU Conformity (CE)	CE1T1410xx ²⁾ & CE1T1411xx ²⁾
	RCM Conformity	CE1T1410en_C1 ²⁾
	UL	UL873 http://ul.com/database
Environmental compatibility	The product environmental declaration CE1E1410 ¹⁾ contains data on environmentally compatible product design and assessments (RoHS compliance, materials composition, packaging, environmental benefit, disposal).	
Dimensions (weight)	Incl. packaging, depending on module type	
	Front module	Between 30 – 50 g
	Base module	Between 60 – 100 g

1) Possible module combinations, see "Type summary, ordering"

2) The documents can be downloaded from <http://siemens.com/bt/download>.

Connection terminals

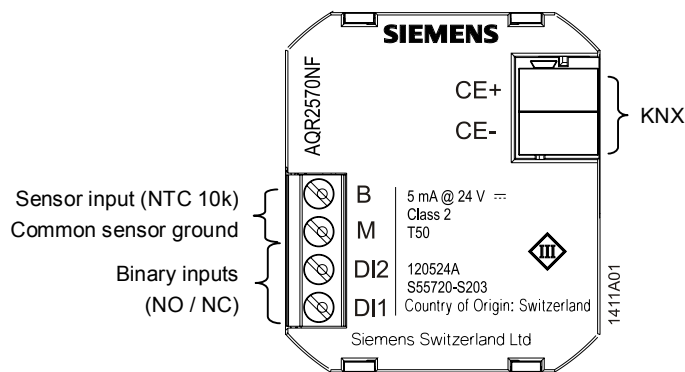

Connection diagram

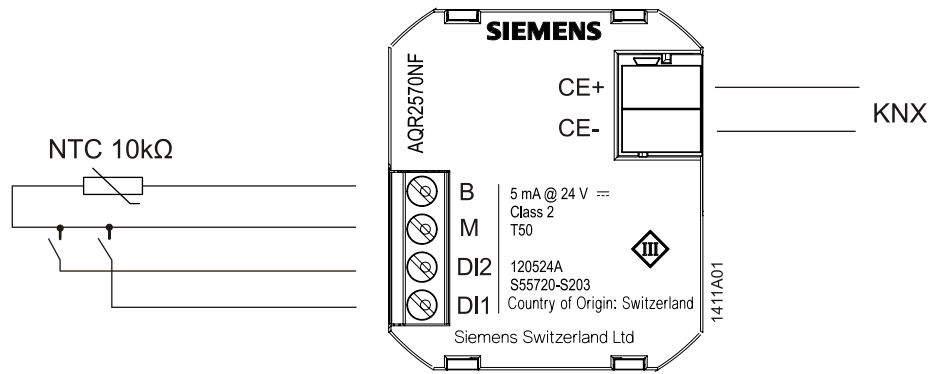

Dimensions (in mm)

Base module

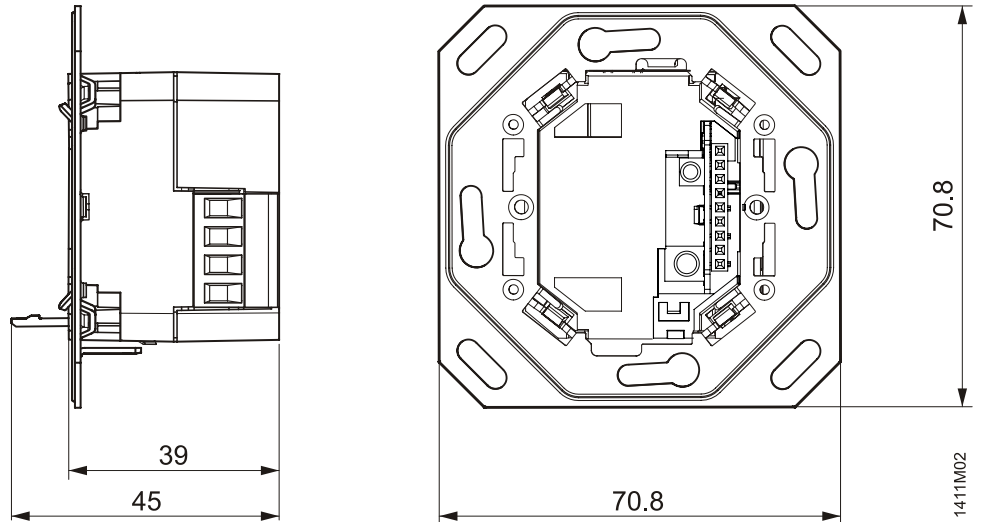

Front and base module (assembled without design frame)

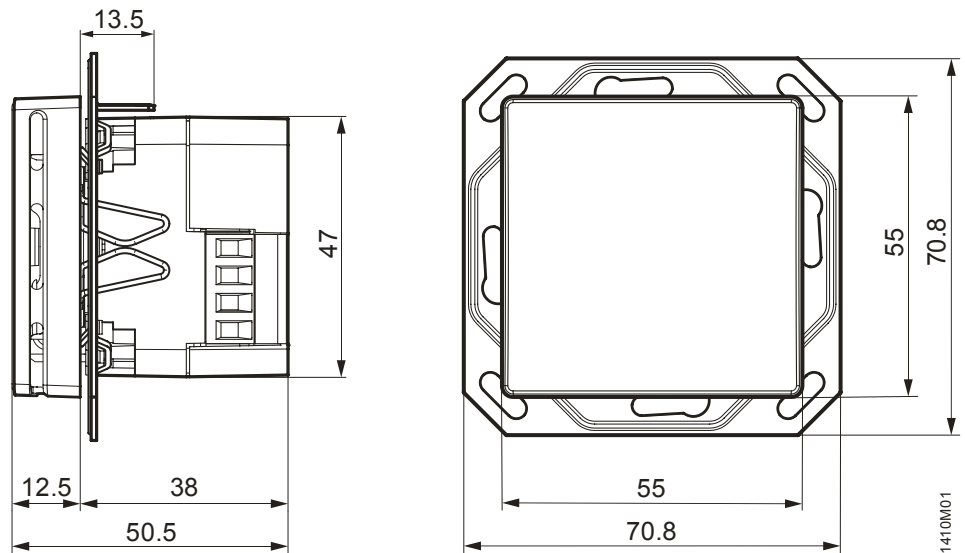

Mounting plate and design frame

Mounting plate "CEE/VDE" (square):

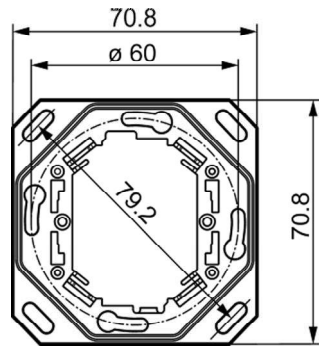

DELTA line design frame:

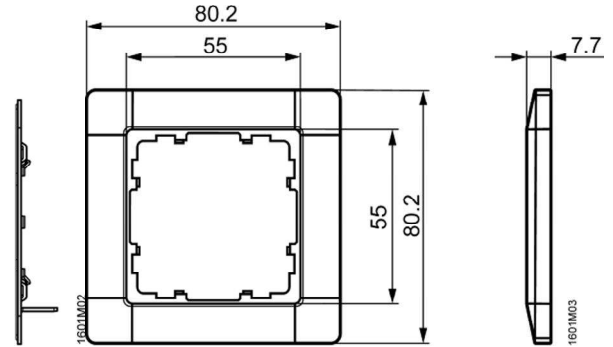

Mounting plate "British standard" (square):

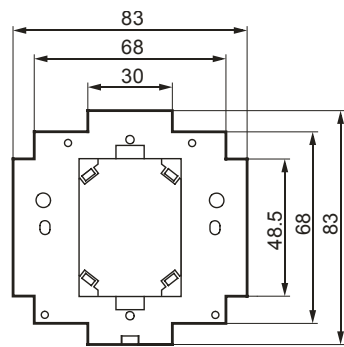

DELTA miro design frame:

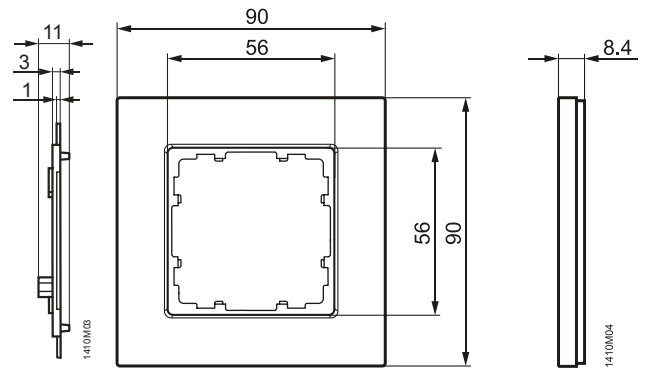

Mounting plate "3 Modular" (horizontal):

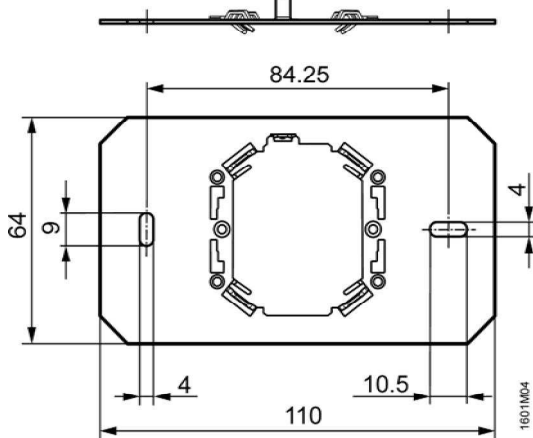

DELTA azio design frame:

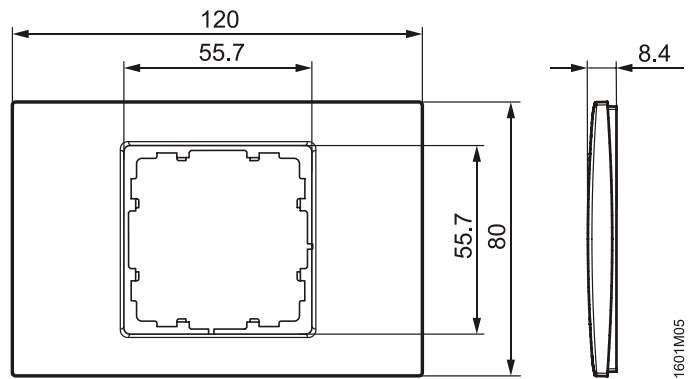

Mounting plate "UL" (vertical):
Dimensions same as for mounting plate "3 Modular" (see above), but vertical

DELTA azio design frame:
Dimensions as for DELTA azio design frame (see above), but vertical