



EN Operating instructions.pages 1 to 6
Translation of the original operating instructions

7 Set-up and maintenance
7.1 Functional testing.4
7.2 Maintenance4

8 Disassembly and disposal
8.1 Disassembly.4
8.2 Disposal4

9 Appendix
9.1 EC Declaration of conformity5

Content

1 About this document
1.1 Function1
1.2 Target group: authorised qualified personnel.1
1.3 Explanation of the symbols used1
1.4 Appropriate use1
1.5 General safety instructions1
1.6 Warning about misuse2
1.7 Exclusion of liability2

2 Product description
2.1 Ordering code2
2.2 Special versions.2
2.3 Destination and use2
2.4 Technical data2
2.5 Safety classification2

3 Mounting
3.1 General mounting instructions3
3.2 Dimensions3

4 Electrical connection
4.1 General information for electrical connection.3
4.2 Wiring requirements.3
4.3 Connection of the safety switchgear3

5 Functions and configuration
5.1 Programming the slave address4
5.2 Configuration of the safety monitor4
5.3 Status signal "safety release"4
5.4 Parameter bit communication monitoring4

6 Diagnostic
6.1 LED indications4

1. About this document

1.1 Function

This operating instructions manual provides all the information you need for the mounting, set-up and commissioning to ensure the safe operation and disassembly of the safety components. The operating instructions must be available in a legible condition and a complete version in the vicinity of the device.

1.2 Target group: authorised qualified personnel

All operations described in this operating instructions manual must be carried out by trained specialist personnel, authorised by the plant operator only.

Please make sure that you have read and understood these operating instructions and that you know all applicable legislations regarding occupational safety and accident prevention prior to installation and putting the component into operation.

The machine builder must carefully select the harmonised standards to be complied with as well as other technical specifications for the selection, mounting and integration of the components.

1.3 Explanation of the symbols used

 **Information, hint, note:**
This symbol is used for identifying useful additional information.

 **Caution:** Failure to comply with this warning notice could lead to failures or malfunctions.
Warning: Failure to comply with this warning notice could lead to physical injury and/or damage to the machine.

1.4 Appropriate use

The products described in these operating instructions are developed to execute safety-related functions as part of an entire plant or machine. It is the responsibility of the manufacturer of a machine or plant to ensure the correct functionality of the entire machinery or plant.

The safety component must be exclusively used in accordance with the versions listed below or for the applications authorised by the manufacturer. Detailed information regarding the range of applications can be found in the chapter "Product description".

1.5 General safety instructions

The user must observe the safety instructions in this operating instructions manual, labelled with the caution or warning symbol above, the country-specific installation standards as well as all prevailing safety regulations and accident prevention rules.

 Further technical information can be found in the Schmersal catalogues or in the online catalogue on the Internet: www.schmersal.net.

The information contained in this operating instructions manual is provided without liability and is subject to technical modifications.

There are no residual risks, provided that the safety instructions as well as the instructions regarding mounting, commissioning, operation and maintenance are observed.

1.6 Warning about misuse



In case of improper use or manipulation of the safety switchgear, personal hazards or damages to machinery or plant components cannot be excluded. The relevant requirements of the standard EN 1088 must be observed.

1.7 Exclusion of liability

We shall accept no liability for damages and malfunctions resulting from defective mounting or failure to comply with this operating instructions manual. The manufacturer shall accept no liability for damages resulting from the use of unauthorised spare parts or accessories.

For safety reasons, invasive work on the device as well as arbitrary repairs, conversions and modifications to the device are strictly forbidden; the manufacturer shall accept no liability for damages resulting from such invasive work, arbitrary repairs, conversions and/or modifications to the device.

2. Product description

2.1 Ordering code

This operating instructions manual applies to the following types:

ASIM-C-M12-①-②

No.	Option	Description
①	4P	4-pole M12 connector for the connection of 2 potential-free NC contacts
	8P	8-pole M12 connector for the connection of 2 potential-free NC contacts or a 24V signal LED
②	0.5M	0.5 m connecting cable with connector
	2M	2 m connecting cable with connector

2.2 Special versions

For special versions, which are not listed in the order code below 2.1, these specifications apply accordingly, provided that they correspond to the standard version.

2.3 Destination and use

The compact ASIM-C-M12 module is a safe input module for safety switchgear with 2 potential-free NC contacts. In the 8-pole M12 connector variant, the module has an additional non-safety-related semi-conductor output for the connection of a 24V LED status indication.

The safety function consists in safely switching off the code transmission when the connected safety contacts are opened and maintaining the safe switched off condition for as long as the contacts are open.

An AS-Interface Safety at Work component functions on the basis of an individual code generator (8 x 4 bit). This safety code is cyclically transmitted over the AS-i network and monitored by a safety monitor.



The user must evaluate and design the safety chain in accordance with the relevant standards and the required safety level.

2.4 Technical data

Standards:	EN 50295, EN/IEC 60204-1
Enclosure:	thermoplastic PBT
Cable:	PUR
Response time:	< 1 ms
Duration of risk:	< 5 ms
Connection:	Cable connector M12, 4/8-pole, A-coded

Ambient conditions

Ambient temperature:	-20 °C ... +60 °C
Storage and transport temperature:	-25 °C ... +80 °C
Resistance to shock:	30 g / 11 ms
Resistance to vibration:	10 ... 57 Hz, Amplitude 0.75 mm
Protection class:	IP67 to IEC/EN 60529
Insulation protection class:	III
Insulation values to IEC/EN 60664-1:	
- Rated impulse withstand voltage U_{imp} :	0.8 kV
- Rated insulation voltage U_i :	32 VDC
- Overvoltage category:	III
- Degree of pollution:	3

Electrical data - AS-Interface

AS-i supply voltage:	26.5 ... 31.6 VDC, protection against polarity reversal
AS-I power consumption:	≤ 90 mA
AS-i specification:	
- Version:	V 3.0
- Profile:	S-7.B.F.0
AS-i inputs:	
- Power supply:	AS-Interface
- Voltage:	20 ... 30 V pulse
- Current:	input current limited ≤ 15 mA, short-circuit proof
- Channel 1	Data bits DI 0/DI 1 = dynamic code transmission
- Channel 2	Data bits DI 2/DI 3 = dynamic code transmission
	Data bits condition static 0 or dynamic code transmission

AS-i Outputs:

- DO 0	LED output (only ASIM-C-M12-8P) Current: 50 mA, overload-proof Voltage: < U-AS-i – 7.0 V
- DO 1 ... DO 3	not used
AS-i Parameter Bits:	
- P0:	communication monitoring
P0 = 1	in case of failure of the AS-i communication the LED output is disabled
P0 = 0	in case of failure of the AS-i communication the status of the LED output is maintained
- P1 ... P3:	not used
Parameter request:	default value parameter request "1111" (0xF)
AS-i Input module address:	0
	- preset to address 0, can be changed through AS-interface bus master or hand-held programming device

LED status display

green LED (AS-i LED):	AS-i supply voltage / Slave address = 0
red LED (AS-i LED):	AS-i communication error / Slave address = 0
yellow LED's:	I1 = Status safety input 1 I2 = Status safety input 2 O1 = Status LED output

2.5 Safety classification

Standards:	EN ISO 13849-1, EN 62061
Control Category:	4
PL:	e
SIL:	suitable for SIL 3 applications
PFH / PFD:	no significant contribution to PFH or PFD of the entire system
Service life:	20 years



Protected wiring!

The cable between the module and the safety switchgear must be protected against mechanical damage in accordance with the requirements of EN/IEC 60204-1

3. Mounting

3.1 General mounting instructions

The mounting holes allow for a mounting with M4 screws onto flat mounting surfaces. The component can be mounted in any position.

3.2 Dimensions

All measurements in mm.

Safety-Input Modul ASIM-C-M12-...

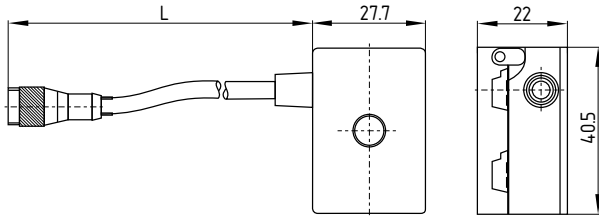

Legend:

L = 0.5 m or 2 m

Enclosure part with mounting holes

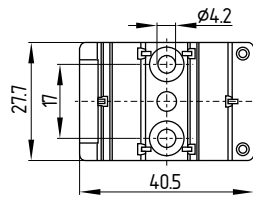

4. Electrical connection

4.1 General information for electrical connection



The electrical connection may only be carried out by authorised personnel in a de-energised condition.

4.2 Wiring requirements

The requirements of EN/IEC 60204-1 regarding protected wiring must always be respected and observed. For the safety assessment of the ASIM-C-M12 input module, the exclusion of faults for a protected wiring has been applied.

4.3 Connection of the safety switchgear

Both safety-related inputs of the module have a cross-wire short monitoring and are designed for 2-channel safety switchgear. At the inputs of the safe input module, only contacts that are designed for safety functions may be connected (refer to the manual of the safety switchgear). Only safety switchgear with 2 potential-free NC contacts can be connected.

Connection of the safety switchgear to ASIM-C-M12-4P-...

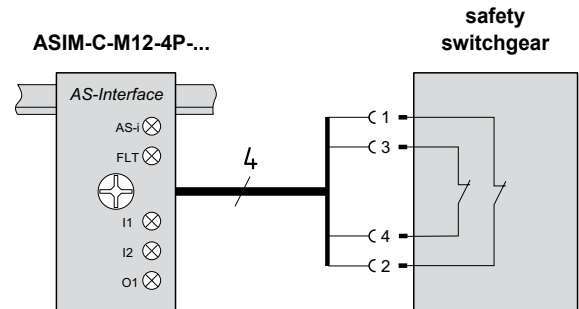

Connection of the safety switchgear to ASIM-C-M12-8P-...

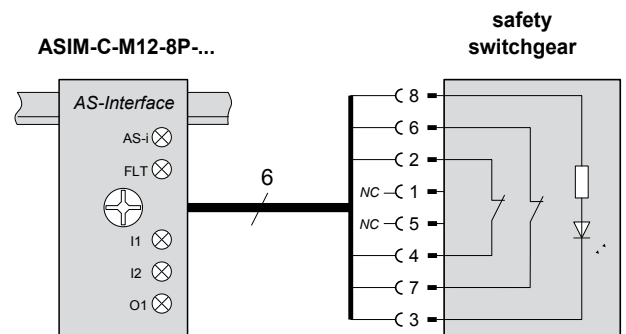

5. Functions and configuration

5.1 Programming the slave address

The slave address is programmed through the AS-i profile cable. Any address from 1 to 31 can be set by means of the AS-i bus master or a hand-held programming device.

5.2 Configuration of the safety monitor

The ASIM-C-M12 can be configured in the ASIMON configuration software with the following monitoring devices (also refer to the ASIMON manual).

Double channel dependent

- Synchronisation time: 0.1 s
- Optionally with startup test
- Optional with local acknowledge

Double channel dependent with filtering

The use of this monitoring device is especially advantageous on safety guards where bounce or vibration against the mechanical stop upon closing is a problem.

- with startup test
- Stabilising time typically 0.5 -1.0 s
- Synchronisation time typically 8.0 – 15.0 s

The safety-monitoring module is only released after expiration of the stabilising time; the synchronization time always must exceed the stabilising time.



The configuration of the safety monitor must be tested and confirmed by a qualified and authorised safety expert/safety engineer.

5.3 Status signal "safety release"

The "safety release" status signal from a Safety at Work slave can be cyclically queried by the control system through the AS-i master. To this effect, the 4 input bits with the varying SaW code of a Safety at Work slave are evaluated through an OR operation with 4 inputs in the control system.

5.4 Parameter bit communication monitoring

The non-safety-related LED output can be configured through parameter port P0 for two types of communication monitoring:

- P0 = 1 (Default) communication monitoring = ON
i.e. in case of failure of the AS-i communication, the LED output is disabled
- P0 = 0 communication monitoring = OFF
i.e. in case of failure of the AS-i communication, the status of the LED output is maintained

6. Diagnostic

6.1 LED indications

The LED's have the following meaning (to EN 50295):

AS-i: (green)	On flashing	AS-Interface voltage OK Slave address = 0
FLT: (red)	On	AS-Interface communication error or slave address = 0

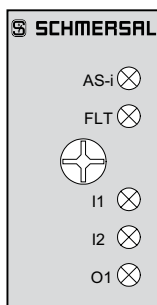

7. Set-up and maintenance

7.1 Functional testing

The safety function of the safe input module and of the connected safety component must be tested.

The following conditions must be previously checked and met:

1. Check the correct fixing of the safe input module and the safety component
2. Protected wiring and fitting and integrity of the power cable
3. The system is free of dirt and soiling

7.2 Maintenance

In the case of correct installation and adequate use, the safe input module features maintenance-free functionality.

A regular visual inspection and functional test, including the following steps, is recommended:

1. Check the safety function
2. Check the fixing and integrity of the safety switchgear, the safe input module and the cable
3. Remove possible dirt and soiling chips

Damaged or defective components must be replaced.

8. Disassembly and disposal

8.1 Disassembly

The safe input module must be disassembled in a de-energised condition only.

8.2 Disposal

The safe input module must be disposed of in an appropriate manner in accordance with the national prescriptions and legislations.

9. Appendix

9.1 EC Declaration of conformity

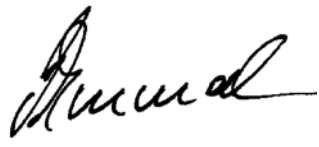
	
<h2>EC Declaration of conformity</h2>	
Translation of the original Declaration of Conformity	K.A. Schmersal GmbH & Co. KG Industrielle Sicherheitssysteme Möddinghofe 30, 42279 Wuppertal Germany Internet: www.schmersal.com
We hereby certify that the hereafter described safety components both in its basic design and construction conform to the applicable European Directives.	
Name of the safety component:	ASIM-C-M12
Type:	See ordering code
Description of the safety component:	Safe AS-i input module for safety switchgear with contact outputs
Relevant EC-Directives:	2006/42/EC-EC-Machinery Directive 2004/108/EC EMC-Directive
Person authorized for the compilation of the technical documentation:	Oliver Wacker Möddinghofe 30 42279 Wuppertal
Place and date of issue:	Wuppertal, December 02, 2013
ASIM-C-M12-A-EN	 Authorised signature Philip Schmersal Managing Director



The currently valid declaration of conformity can be downloaded from the internet at www.schmersal.net.



K. A. Schmersal GmbH & Co. KG
Möddinghofe 30, D - 42279 Wuppertal
Postfach 24 02 63, D - 42232 Wuppertal

Telefon +49 - (0)2 02 - 64 74 - 0
Telefax +49 - (0)2 02 - 64 74 - 1 00
E-mail: info@schmersal.com
Internet: <http://www.schmersal.com>