



EN Operating instructions.pages 1 to 6
Translation of the original operating instructions

Content	
1 About this document	
1.1 Function	1
1.2 Target group: authorised qualified personnel.	1
1.3 Explanation of the symbols used	1
1.4 Appropriate use	1
1.5 General safety instructions	1
1.6 Warning about misuse	2
1.7 Exclusion of liability	2
2 Product description	
2.1 Ordering code	2
2.2 Special versions.	2
2.3 Destination and use	2
2.4 Technical data	2
2.5 Safety classification emergency stop.	3
3 Mounting	
3.1 General mounting instructions	3
3.2 Dimensions	3
3.3 Mounting of the control panel.	3
3.4 Inscription plates with fastening clips.	3
4 Electrical connection	
4.1 General information for electrical connection.	4
5 Functions and configuration	
5.1 Positions of the actuating elements	4
5.2 Emergency stop function	4
5.3 Configuration of the safety monitor	4
5.4 Function of the command and signalling devices	4
5.5 Programming the slave address	5
5.6 Status signal "safety release"	5
6 Set-up and maintenance	
6.1 Functional testing.	5
6.2 Maintenance	5

7 Disassembly and disposal	
7.1 Disassembly.	5
7.2 Disposal	5
8 Appendix	
8.1 EC Declaration of conformity	6

1. About this document

1.1 Function
This operating instructions manual provides all the information you need for the mounting, set-up and commissioning to ensure the safe operation and disassembly of the safety switchgear. The operating instructions must be available in a legible condition and a complete version in the vicinity of the device.

1.2 Target group: authorised qualified personnel
All operations described in this operating instructions manual must be carried out by trained specialist personnel, authorised by the plant operator only.

Please make sure that you have read and understood these operating instructions and that you know all applicable legislations regarding occupational safety and accident prevention prior to installation and putting the component into operation.

The machine builder must carefully select the harmonised standards to be complied with as well as other technical specifications for the selection, mounting and integration of the components.

1.3 Explanation of the symbols used

 **Information, hint, note:**
This symbol is used for identifying useful additional information.

 **Caution:** Failure to comply with this warning notice could lead to failures or malfunctions.
Warning: Failure to comply with this warning notice could lead to physical injury and/or damage to the machine.

1.4 Appropriate use
The products described in these operating instructions are developed to execute safety-related functions as part of an entire plant or machine. It is the responsibility of the manufacturer of a machine or plant to ensure the correct functionality of the entire machinery or plant.

The safety switchgear must be exclusively used in accordance with the versions listed below or for the applications authorised by the manufacturer. Detailed information regarding the range of applications can be found in the chapter "Product description".

1.5 General safety instructions
The user must observe the safety instructions in this operating instructions manual, the country-specific installation standards as well as all prevailing safety regulations and accident prevention rules.

 Further technical information can be found in the Schmersal catalogues or in the online catalogue on the Internet: www.schmersal.net.

The information contained in this operating instructions manual is provided without liability and is subject to technical modifications.

There are no residual risks, provided that the safety instructions as well as the instructions regarding mounting, commissioning, operation and maintenance are observed.

x.000 / Mai 2014 / v.A. - 101214289-EN / B / 2014-05-09 / AE-Nr. 2897

1.6 Warning about misuse



In case of improper use or manipulation of the safety switch-gear, personal hazards or damages to machinery or plant components cannot be excluded. The relevant requirements of the standard EN ISO 13850 must be observed.

1.7 Exclusion of liability

We shall accept no liability for damages and malfunctions resulting from defective mounting or failure to comply with this operating instructions manual. The manufacturer shall accept no liability for damages resulting from the use of unauthorised spare parts or accessories.

For safety reasons, invasive work on the device as well as arbitrary repairs, conversions and modifications to the device are strictly forbidden; the manufacturer shall accept no liability for damages resulting from such invasive work, arbitrary repairs, conversions and/or modifications to the device.

2. Product description

2.1 Ordering code

This operating instructions manual applies to the following types:

BDF 200 ①-AS ②-③-④-⑤-⑥

No.	Option	Description	
①	ST1	Connector plug M 12, bottom	
	ST2	Connector plug M12, top (not for option G24)	
②	Pos. 1	Command device	
	NH	Emergency stop without protective collar	
	NHK	Emergency stop with protective collar	
③	Pos. 2	Command and signalling device:	
	WS 2 / 3..	Maintained selector switch, 2 or 3 positions	
	WT. 2 / 3..	Maintained spring-return rotary selector switch, 2 or 3 positions	
	SWS / SWT 20	Key-operated selector switch 2 positions	
LT..		Illuminated pushbutton	
	LM..	Illuminated signal	
	DT..	Pushbutton	
④	Pos. 3	Command and signalling device:	
	LT..	Illuminated pushbutton	
	LM..	Illuminated signal	
DT..		Pushbutton	
	⑤	Pos. 4	Command and signalling device:
		LT..	Illuminated pushbutton
LM..		Illuminated signal	
DT..		Pushbutton	
	⑥		without indicator lamp
G24		Indicator lamp G24, top	



The unused positions 2 - 4 are labelled "B" and are sealed with a blanking plug in factory.



Only if the information described in this operating instructions manual are realised correctly, the safety function and therefore the compliance with the Machinery Directive is maintained.

2.2 Special versions

For special versions, which are not listed in the order code below 2.1, these specifications apply accordingly, provided that they correspond to the standard version.

2.3 Destination and use

The modular BDF 200 AS control panel is installed on the safety guard of a machine or plant. It enables the operator to activate for instance the emergency stop, start/stop and reset functions.

The emergency stop command device is used on machinery and plants as a safe command device to generate a safe signal initiating the shut-down of a hazardous movement when actuated. The emergency stop command device must only be used in combination with the AS-i ASM safety monitor. The integrated AS-i safety module is used to detect safety-relevant switching conditions of mechanical contacts.

An AS-Interface Safety at Work component functions on the basis of an individual code generator (8 x 4 bit). This safety code is cyclically transmitted over the AS-i network and monitored by the ASM safety monitor.



The user must evaluate and design the safety chain in accordance with the relevant standards and the required safety level.



Maintenance: Please observe that the safety function must be triggered at least once a year to test the system!

2.4 Technical data

Standards: EN 60947-5-1, EN ISO 13850, EN ISO 13849-1, IEC 61508, EN 50295

Enclosure: glass-fibre reinforced thermoplastic, self-extinguishing

Mechanical life: command devices: 1 million operations; emergency stop: 100,000 operations

Response time: < 100 ms

Connection: Connector plug M12, 4-pole,

Lamp socket: BA5S, only LED, max. length 17 mm

LED change: from front

Electrical data - AS-Interface:

AS-i supply voltage: 18,0 ... 31.6 VDC, through AS-Interface, reverse polarity-proof (stabilised PELV unit)

AS-I power consumption: ≤ 150 mA

AS-i Device insulation: internal short-circuit proof

AS-i specification Safety-Slave:

Version: V 3.0

Profile: S-7.B.F.F

IO-Code: 0x7

ID-Code: 0xB

ID-Code 1: 0xF

ID-Code 2: 0xF

AS-interface inputs:

Channel 1: DI 0 / DI 1 = dynamic code transmission

Channel 2: DI 2 / DI 3 = dynamic code transmission

AS-interface outputs:

DO 0 indicator lamp G24 red

DO 1 indicator lamp G24 green

DO 2 ... DO 3 not used

AS-Interface parameter port: P0 ... P3: not used

AS-i specification A/B-Slave:

Version: V 3.0

Profile: S-7.A.7.E

IO-Code: 0x7

ID-Code: 0xA

ID-Code 1: 0x7

ID-Code 2: 0xE

AS-interface inputs:

DI 0 button Pos. 4

DI 1 button Pos. 3

DI 2 button / switch Pos. 2

DI 3 button / switch Pos. 2

AS-interface outputs:

DO 0 light element Pos. 4

DO 1 light element Pos. 3

DO 2 light element Pos. 2

DO 3 not used

AS-Interface parameter port: P0 ... P3: not used
 Input module address: 0,
 preset to address 0, can be
 changed through AS-interface bus master
 or hand-held programming device

Ambient conditions:

Ambient temperature:	-25 °C ... +65 °C
Storage and transport temperature:	-25 °C ... +85 °C
Climatic resistance:	to DIN EN 60068 Part 2 - 30
Protection class:	IP65
Protection class:	II □
Resistance to vibration:	10 ... 150 Hz (0.35 mm / 5 g)
Resistance to shock:	15 g / 11 ms
Overvoltage category:	III
Degree of pollution:	3
Rated impulse withstand voltage U_{imp} :	800 V
Rated insulation voltage U_i :	32 VDC

2.5 Safety classification emergency stop

Standards:	EN ISO 13849-1, IEC 61508
PL:	up to e
Control category:	up to 4
PFH-value:	$\leq 1.4 \times 10^{-8}$ /h up to max. 5,000 switching cycles/year
SIL:	up to 3
Service life:	20 years

3. Mounting

3.1 General mounting instructions

For the correct fixing of the BDF 200 AS control panel, the device is provided with two mounting holes for M5 screws are provided. Any mounting position.



Please observe the remarks of the standards EN ISO 12100, EN 953 and EN 1088.

3.2 Dimensions

All measurements in mm.

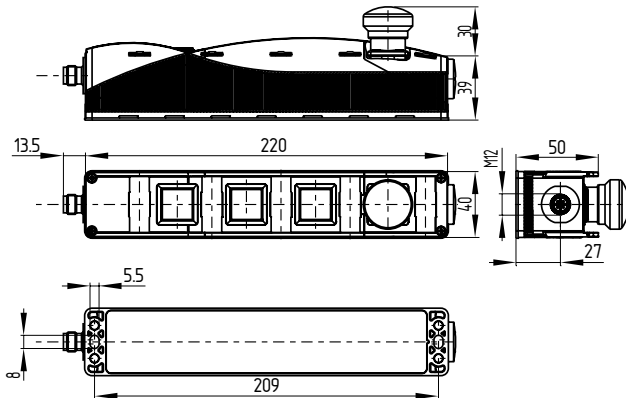

3.3 Mounting of the control panel

Remove the cover of the enclosure a and b (screws: Torx 10).



When opening the enclosure cover, please avoid damage to the connecting cables.



Caution!
 Do not touch electrostatically loaded elements.
 Do not touch the printed circuit board.

Use 2 x M5 cylindrical screws ISO 4762 (DIN 912) for the assembly.



When closing the enclosure cover, please observe that the individual cables are not caught between the command device and the contact element.

After fitting, the cover screws must be tightened with a tightening torque of 0.7 - 0.8 Nm.

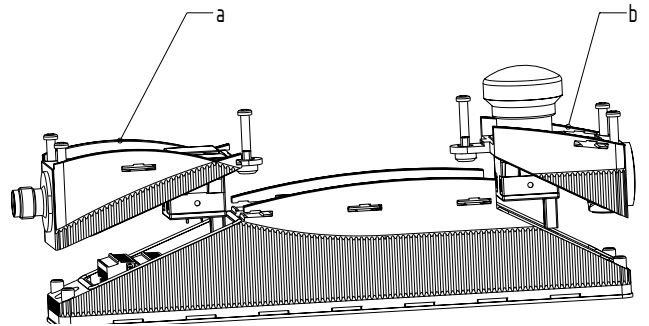

3.4 Inscription plates with fastening clips

The identification fields can be labelled with two-layer plastic inscription fields (included in delivery). After that, they are fixed with the fastening clips (included in delivery).

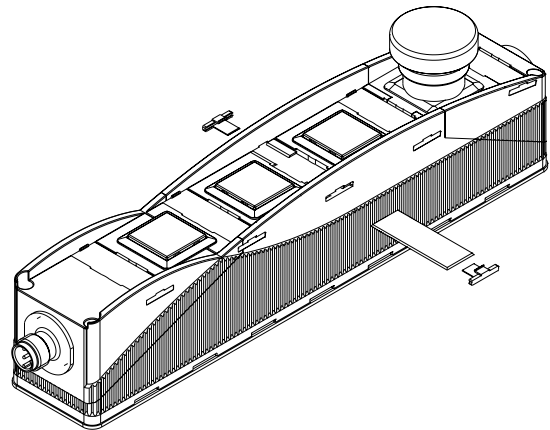

4. Electrical connection

4.1 General information for electrical connection



The electrical connection may only be carried out by authorised personnel in a de-energised condition.

The AS-i Safety Slave with emergency stop function and the AS-i A/B Slave with the functions of the command and signalling devices are supplied by the AS-Interface cable.

The connection to the AS-Interface system is realised through an M12 connector. The connector is A-coded, the wiring configuration is determined as follows (to EN 50295).

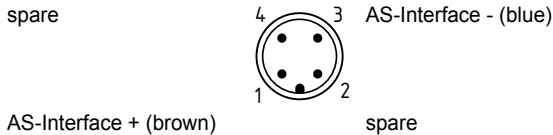

5. Functions and configuration

5.1 Positions of the actuating elements

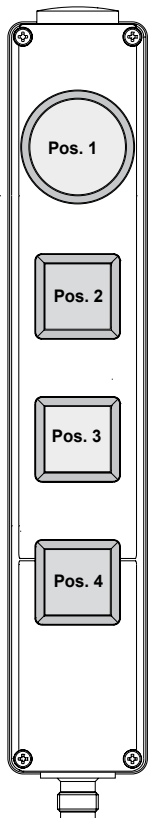

5.2 Emergency stop function

Position 1: AS-i Safety-Slave

Emergency stop pushbutton and G24 indicator lamp:

NH, NHK, G24

- Emergency stop DI 0 ... DI 3, dynamic code transmission
- Indicator lamp DO 0 RED
- Indicator lamp DO 1 GREEN

5.3 Configuration of the safety monitor

The emergency stop function of the BDF 200 AS can be configured in the ASIMON configuration software with the following monitoring devices (also refer to the ASIMON manual).

Double channel forced

- Optionally with startup test
- Optional with local acknowledge



The configuration of the safety monitor must be tested and confirmed by a qualified and authorised safety expert/safety engineer.

5.4 Function of the command and signalling devices

Position 2: AS-i A/B-Slave

Maintained selector switch / spring-return selector switch, 2 positions:

WS20, WT20, SWS20, SWT20

- Position 0 ---
- Position 1 DI 2 and DI 3



Maintained selector switch / spring-return selector switch, 3 positions:

WS30, WT30, WTS30

- Position 1 DI 3
- Position 0 ---
- Position 2 DI 2

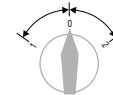

WTS30: position 1 = latching; position 2 = pushbutton function

Illuminated pushbuttons, pushbuttons and indicator lights:

LT., DT., LM..

- Pushbutton function DI 2 and DI 3
- Indicator lights DO 2



Position 3: AS-i A/B-Slave

Illuminated pushbuttons, pushbuttons and indicator lights:

LT., DT., LM..

- Pushbutton function DI 1
- Indicator lights DO 1



Position 4: AS-i A/B-Slave

Illuminated pushbuttons, pushbuttons and indicator lights:

LT., DT., LM..

- Pushbutton function DI 0
- Indicator lights DO 0



5.5 Programming the slave address

The slave addresses for both integrated AS-i slaves are programmed through the M12 connector.

To that effect the lower enclosure cover must be opened. By means of the there-located DIP switches, both AS-i slaves can be individually separated from or connected to the AS-i connection.

- DIP-SW 1 AS-i A/B-Slave
- DIP-SW 2 AS-i Safety-Slave

For the AS-i Safety-Slave an address from 1 to 31 and for the AS-i A/B slave an address from 1A to 31B can be set by means of an AS-i bus master or a hand-held programming device.

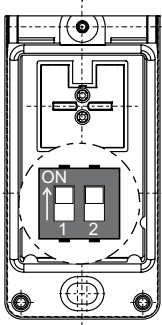

DIP-SW 1: AS-i A/B-Slave
DIP-SW 2: AS-i Safety-Slave



Caution!

Do not touch electrostatically loaded elements.
Do not touch the printed circuit board.

5.6 Status signal "safety release"

The "safety release" status signal from a Safety at Work slave can be cyclically queried by the control system through the AS-i master. To this effect, the 4 input bits with the varying SaW code of a Safety at Work slave are evaluated through an OR operation with 4 inputs in the control system.

6. Set-up and maintenance

6.1 Functional testing

The safety function of the safety components must be tested. The following conditions must be checked and met:

- Correct fixing of the fitted component
- Check the integrity of the cables and connections
- Check the command and signalling devices for damage

6.2 Maintenance

The function of the emergency stop button must be tested in regular intervals.



Maintenance: Please observe that the safety function must be triggered at least once a year to test the system!

In case of correct installation in accordance with the above-described instructions, the component requires little maintenance. Under extreme conditions, we recommend routine maintenance as follows:

- Check the correct fixing of the control panel
- Remove particles of dust and soiling.
- Check the integrity of the cables and connections

Damaged or defective components must be replaced.

7. Disassembly and disposal

7.1 Disassembly

The safety switchgear must be disassembled in a de-energised condition only.

7.2 Disposal

The safety switchgear must be disposed of in an appropriate manner in accordance with the national prescriptions and legislations.

8.1 EC Declaration of conformity

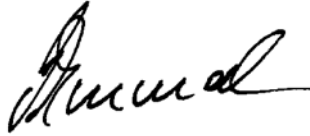
	
<h2>EC Declaration of conformity</h2>	
Translation of the original Declaration of Conformity	K.A. Schmersal GmbH & Co. KG Möddinghofe 30 42279 Wuppertal Germany www.schmersal.com
<p>We hereby certify that the hereafter described safety components both in its basic design and construction conform to the applicable European Directives.</p>	
Name of the safety component:	BDF 200 AS
Type:	Refer to ordering code
Description of the safety component:	Control panel with emergency stop function and integrated AS-i Safety at Work
Relevant EC-Directives:	2006/42/EC-EC-Machinery Directive 2004/108/EC EMC-Directive
Person authorized for the compilation of the technical documentation:	Oliver Wacker Möddinghofe 30 42279 Wuppertal
Place and date of issue:	Wuppertal, May 9, 2014
BDF200AS-B-EN	
	Authorised signature Philip Schmersal Managing Director



The currently valid declaration of conformity can be downloaded from the internet at www.schmersal.net.



K. A. Schmersal GmbH & Co. KG
Möddinghofe 30, D - 42279 Wuppertal
Postfach 24 02 63, D - 42232 Wuppertal

Phone: +49 - (0)2 02 - 64 74 - 0
Telefax: +49 - (0)2 02 - 64 74 - 1 00
E-Mail: info@schmersal.com
Internet: <http://www.schmersal.com>