



**EN** Operating instructions. . . . . pages 1 to 6  
Translation of the original operating instructions

**FR** Vous trouverez la version actuelle du mode d'emploi dans votre langue nationale officielle sur l'Internet, [www.schmersal.net](http://www.schmersal.net).

**ES** Encontrará el manual de instrucciones actual en su idioma oficial de la UE en nuestra página de Internet [www.schmersal.net](http://www.schmersal.net).

**NL** U vindt de huidige versie van de gebruikshandleiding in uw officiële landstaal op het Internet, [www.schmersal.net](http://www.schmersal.net).

**IT** Il manuale d'istruzioni aggiornato nella vostra lingua (lingua ufficiale UE) è scaricabile in Internet all'indirizzo [www.schmersal.net](http://www.schmersal.net).

**JP** EU公用語で書かれた最新の取扱説明書は、インターネット ([www.schmersal.net](http://www.schmersal.net)) からダウンロードできます。

**Content**

**1 About this document**  
1.1 Function . . . . . 1  
1.2 Target group: authorised qualified personnel. . . . . 1  
1.3 Explanation of the symbols used . . . . . 1  
1.4 Appropriate use . . . . . 1  
1.5 General safety instructions . . . . . 1  
1.6 Warning about misuse . . . . . 1  
1.7 Exclusion of liability . . . . . 2

**2 Product description**  
2.1 Ordering code . . . . . 2  
2.2 Special versions. . . . . 2  
2.3 Destination and use . . . . . 2  
2.4 Technical data . . . . . 2  
2.5 Safety classification . . . . . 2

**3 Mounting**  
3.1 General mounting instructions . . . . . 3  
3.2 Dimensions . . . . . 3  
3.3 Mounting of the actuating heads . . . . . 3  
3.4 Actuation of the position switches . . . . . 4

**4 Electrical connection**  
4.1 General information for electrical connection. . . . . 4

**5 Functions and configuration**  
5.1 Programming the slave address . . . . . 5  
5.2 Configuration of the safety monitor . . . . . 5  
5.3 Status signal "safety release" . . . . . 5

**6 Diagnostic**  
6.1 LED indications . . . . . 5  
6.2 Read-out of the parameter ports . . . . . 5

**7 Set-up and maintenance**  
7.1 Functional testing. . . . . 5  
7.2 Maintenance . . . . . 5

**8 Disassembly and disposal**  
8.1 Disassembly. . . . . 5  
8.2 Disposal . . . . . 5

**9 Appendix**  
9.1 EC Declaration of conformity . . . . . 6

**1. About this document**

**1.1 Function**

This operating instructions manual provides all the information you need for the mounting, set-up and commissioning to ensure the safe operation and disassembly of the safety switchgear. The operating instructions must be available in a legible condition and a complete version in the vicinity of the device.

**1.2 Target group: authorised qualified personnel**

All operations described in this operating instructions manual must be carried out by trained specialist personnel, authorised by the plant operator only.

Please make sure that you have read and understood these operating instructions and that you know all applicable legislations regarding occupational safety and accident prevention prior to installation and putting the component into operation.

The machine builder must carefully select the harmonised standards to be complied with as well as other technical specifications for the selection, mounting and integration of the components.

**1.3 Explanation of the symbols used**



**Information, hint, note:**

This symbol is used for identifying useful additional information.



**Caution:** Failure to comply with this warning notice could lead to failures or malfunctions.

**Warning:** Failure to comply with this warning notice could lead to physical injury and/or damage to the machine.

**1.4 Appropriate use**

The products described in these operating instructions are developed to execute safety-related functions as part of an entire plant or machine. It is the responsibility of the manufacturer of a machine or plant to ensure the correct functionality of the entire machinery or plant.

The safety switchgear must exclusively be used in accordance with the versions listed below or for the applications authorised by the manufacturer. Detailed information regarding the range of applications can be found in the chapter "Product description".

**1.5 General safety instructions**

The user must observe the safety instructions in this operating instructions manual, the country-specific installation standards as well as all prevailing safety regulations and accident prevention rules.



Further technical information can be found in the Schmersal catalogues or in the online catalogue on the Internet: [www.schmersal.net](http://www.schmersal.net).

The information contained in this operating instructions manual is provided without liability and is subject to technical modifications.

There are no residual risks, provided that the safety instructions as well as the instructions regarding mounting, commissioning, operation and maintenance are observed.

**1.6 Warning about misuse**



In case of inadequate or improper use or manipulations of the safety switchgear, personal hazards or damage to machinery or plant components cannot be excluded. The relevant requirements of the standard EN 1088 must be observed.

### 1.7 Exclusion of liability

We shall accept no liability for damages and malfunctions resulting from defective mounting or failure to comply with this operating instructions manual. The manufacturer shall accept no liability for damages resulting from the use of unauthorised spare parts or accessories.

For safety reasons, invasive work on the device as well as arbitrary repairs, conversions and modifications to the device are strictly forbidden; the manufacturer shall accept no liability for damages resulting from such invasive work, arbitrary repairs, conversions and/or modifications to the device.

## 2. Product description

### 2.1 Ordering code

This operating instructions manual applies to the following types:

①② 256 ③-AS 2S

No.	Option	Description
①	Z T	Snap action ⊖ Slow action ⊖
②	Actuator selection	refer to main catalogue Safety Technology
③	STL FKL	Connector plug M 12, left IDC connector left



Only if the information described in this operating instructions manual are realised correctly, the safety function and therefore the compliance with the Machinery Directive is maintained.

### 2.2 Special versions

For special versions, which are not listed in the order code below 2.1, these specifications apply accordingly, provided that they correspond to the standard version.

### 2.3 Destination and use

The safety switch is suitable for hinged or sliding guards, which need to be closed in order to provide for the necessary operational safety. The combination of the safety switch and the AS-i ASM safety monitor provides a safe monitoring of the condition of the corresponding safety guard.

The safety function consists in safely switching off the code transmission when the safety guard is opened and maintaining the safe switched off condition for as long as the safety guard is open.

An AS-Interface Safety at Work component functions on the basis of an individual code generator (8 × 4 bit). This safety code is cyclically transmitted over the AS-i network and monitored by the ASM safety monitor. The component status can be evaluated through a PLC with AS-Interface master. The safety-related functions are enabled by means of the AS-i safety monitor.



The user must evaluate and design the safety chain in accordance with the relevant standards and the required safety level.

### 2.4 Technical data

Standards:	EN 60947-5-1, EN 50295, EN ISO 13849-1, IEC 61508
Design:	fixings to EN 50047
Enclosure:	glass-fibre reinforced thermoplastic, self-extinguishing
Switching system:	Slow action or snap action, positive break NC contact ⊖
Mechanical life:	> 1 million operations
Switching frequency:	max. 5000/h
Max. Actuating speed:	1 m/s
Response time:	< 100 ms
Connection AS Interface:	Connector plug M12, 4-pole or flat cable clamp
Termination 2 <sup>nd</sup> switch:	M12 connector plug, 4-pole

### Electrical data - AS-Interface:

AS-i supply voltage:	18.0 ... 31.6 VDC, through AS-Interface, reverse polarity-proof (stabilised PELV unit)
AS-I power consumption:	≤ 0.05 A
AS-i device insulation:	internal short-circuit proof

### AS-I specification:

Version:	V 3.0
Profile:	S-0.B.F.F
IO-Code:	0×0
ID-Code:	0×B
ID-Code 1:	0×F
ID-Code 2:	0×F

### AS-interface inputs:

Channel 2 (Z/T 256 AS):	DI 0 / DI 1 = dynamic code transmission
Channel 2 (2 <sup>nd</sup> switch):	DI 2 / DI 3 = dynamic code transmission

### AS-interface outputs:

DO 0 ... DO 3:	no function
----------------	-------------

### AS-Interface parameter port:

P0:	Channel 2 switched, switching condition 2 <sup>nd</sup> switch
P1 ... P3:	no function
Input module address:	preset to address 0, can be changed through AS-interface bus master or hand-held programming device

### LED status display:

LED yellow:	Channel 1, SaW-Bit 0,1, Z/T 256 AS
LED green-red (AS-i Duo LED):	AS-Interface supply voltage / AS-Interface communication error / slave address = 0 or periphery error detected
LED yellow:	channel 2, SaW bit 2,3, 2 <sup>nd</sup> switch

### Ambient conditions:

Protection class:	IP 67
Ambient temperature:	-25 °C ... +60 °C
Storage and transport temperature:	25 °C ... +85 °C
Relative humidity:	30 ... 95%, no condensation, no icing
Resistance to vibration:	10 ... 150 Hz (0.35 mm / 5 g)
Resistance to shock:	30 g / 11 ms
Protection class:	II □
Overvoltage category:	III
Degree of pollution:	3
Rated impulse withstand voltage $U_{imp}$ :	800 V
Rated insulation voltage $U_i$ :	32 VDC

### 2.5 Safety classification

#### A) Two dependent position switches on a safety guard

Standards:	EN ISO 13849-1, IEC 61508
PL:	up to e
Control category:	up to 4
PFH-value:	≤ 1.4 × 10 <sup>-8</sup> /h up to max. 100,000 switching cycles/year
SIL:	up to 3
Service life:	20 years

#### B) Always one independent position switch on two safety guards

Standards:	EN ISO 13849-1, IEC 61508
PL:	up to c
Control category:	up to 1
PFH-value:	≤ 1.4 × 10 <sup>-6</sup> /h up to max. 100,000 switching cycles/year
SIL:	up to 1
Service life:	20 years

**3. Mounting**

**3.1 General mounting instructions**

The mounting dimensions are mentioned at the rear of the enclosure. The fixing screws must be protected against unauthorised tampering. The switch enclosure must not be used as an end stop. Any mounting position. To ensure a proper functioning, the switch must be installed so that the required switch travel is obtained. For safety functions, at least the positive break travel indicated in the switch travel diagram (refer to catalogue) must be obtained. All components have sufficient after-travel to compensate for inaccuracies in the guidance of the actuating system. The actuation of the switch beyond its end stop however must be avoided.



Please observe the remarks of the standards EN ISO 12100, EN 953 and EN 1088.

**3.2 Dimensions**

All measurements in mm.

**Z/T 256 AS with Connector plug M 12**

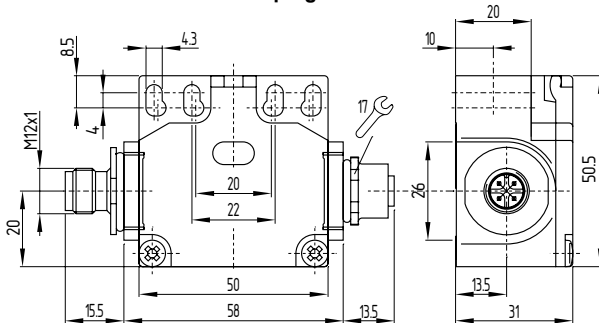

**Z/T 256 AS with IDC connector**

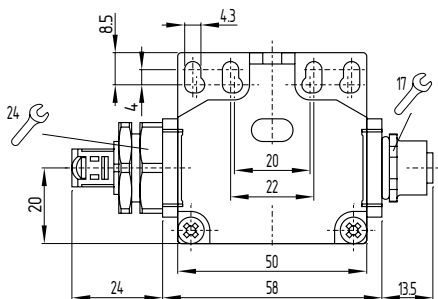

**Actuator heads Z/T.. 256 AS**

Selection and dimensions refer to SCHMERSAL Main catalogue Safety Technology

**3.3 Mounting of the actuating heads**

**Repositioning the actuating heads (R, 1R, K, 3K, 4K, V, V.H)**

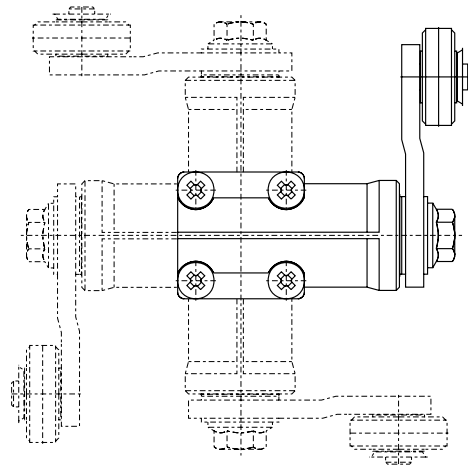

The actuating head can be repositioned by 4 x 90°. Unscrew the four screws of the actuating head, reposition the actuating head in the desired position and retighten the four screws.

**Repositioning the roller lever (H)**

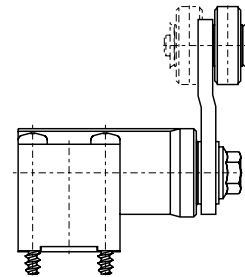

The (offset) roller arm may be reversed, so that the roller faces the inside of the arm.

**Positioning the lever (.H)**

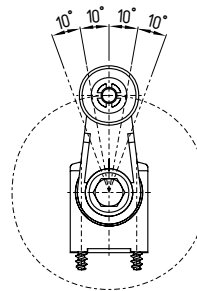

The roller lever can be repositioned over 10° on the toothed shaft in 360° steps. Unscrew the hexagonal screw for approx. 4 mm, position the lever in the desired position and retighten the screw.

**Length-adjustable lever (7H, 10H)**

To adjust the length of the lever, unscrew the fixing screw of the lever. Firmly retighten the screw after the length adjustment.

**3.4 Actuation of the position switches**

**Top plunger**

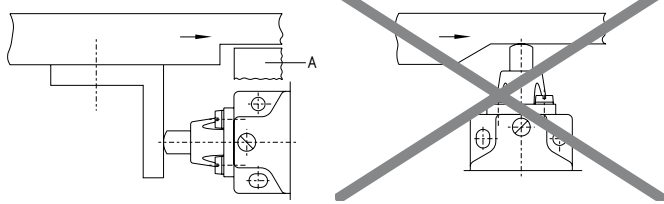

**A Stop**

**Roller plunger**

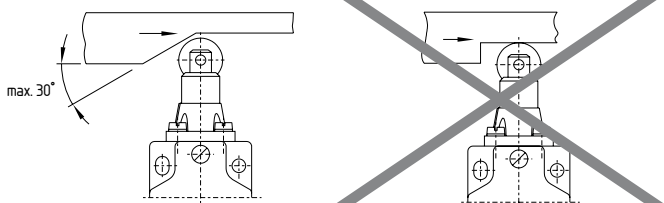

**Cam Leading edge**

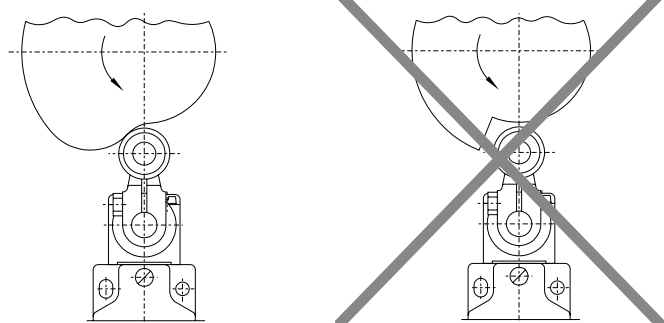

**Cam Trailing edge**

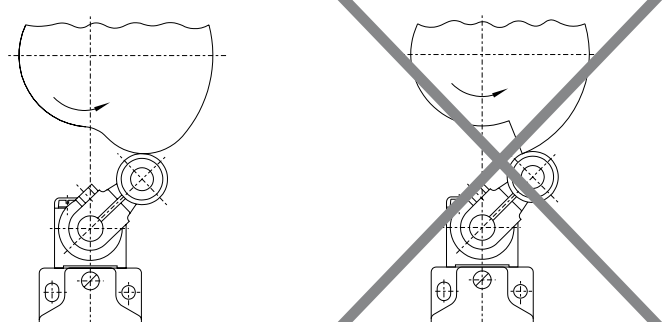

**4. Electrical connection**

**4.1 General information for electrical connection**



The electrical connection may only be carried out by authorised personnel in a de-energised condition.

The connection to the AS-Interface system is realised through an M12 connector or an AS-i flat cable clamp. The wiring configuration of the M12 connector is defined as follows (to EN 50295):

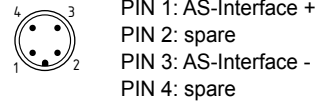

The second position switch is connected through the M12 connector. The wiring configuration is as follows:

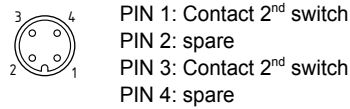

For function variant A) with two position switches on a safety guard, the NO contact of the second position switch must be connected.

For function variant B) with each time one position switch on two safety guards, the positive-break NC contact of the second position switch must be connected.

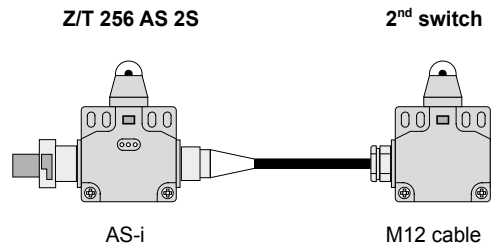

### 5. Functions and configuration

#### 5.1 Programming the slave address

The slave address is programmed through the AS-i connector. Any address from 1 to 31 can be set by means of the AS-i bus master or a hand-held programming device.

#### 5.2 Configuration of the safety monitor

The safety switch can be configured in the ASIMON configuration software with the following safety-monitoring modules (refer to ASIMON manual):

##### A) Two dependent position switches on a safety guard

###### Double channel dependent

- Optionally with startup test
- Synchronisation time typically 0.5 - 2.0 s

###### Double channel dependent with filtering

The use of this safety-monitoring module is especially advantageous on safety guards where bounce or vibration against the mechanical stop upon closing is a problem.

- Optionally with startup test
- Stabilising time typically: 0.5 - 1.0 s
- Synchronisation time typically 5.0 - 10.0 s

The safety-monitoring module is only released after expiration of the stabilising time; the synchronization time always must exceed the stabilising time.

##### B) Always one independent position switch on two safety guards

###### Double channel independent

- Optionally with startup test



The configuration of the safety monitor must be tested and confirmed by a qualified and authorised safety expert/safety engineer.

#### 5.3 Status signal "safety release"

The "safety release" status signal from a Safety at Work slave can be cyclically queried by the control system through the AS-i master. To that effect, the 4 input bits with the varying SaW code of a Safety at Work slave are evaluated through an OR operation with 4 inputs in the control system.

### 6. Diagnostic

#### 6.1 LED indications

The LED's have the following meaning (to EN 50295):

- LED yellow:** Channel 1 / AS-i SaW bit 0,1, Z/T 256 AS
- LED green/red** (AS-i duo LED): AS-Interface supply voltage/  
AS-Interface communication error  
or slave address = 0  
or periphery error
- LED yellow:** Channel 2 / AS-i SaW bit 2, 3, 2<sup>nd</sup> switch

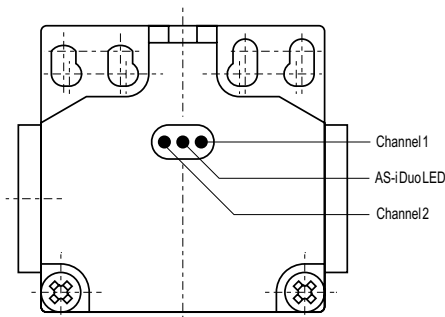

#### 6.2 Read-out of the parameter ports

The parameter port P0 to P3 of an AS-i slave can be read out through the control interface of the AS-i master (see component description) by means of the "Write parameter" instruction (with hexadecimal value F). This (non-safe) diagnostic information from the reflected parameters or the answer to a "Write parameter instruction" can be used by the user for diagnostic purposes or for the control programme.

Table 3: diagnostic information (P0 ... P3)

Parameter bit	Condition = 1	Condition = 0
0	Channel 2 activated	Channel 2 disabled
1	—	—
2	—	—
3	—	—

### 7. Set-up and maintenance

#### 7.1 Functional testing

The safety function of the safety components must be tested. The following conditions must be previously checked and met:

1. Check the switch enclosure for damage.
2. Check the free movement of the actuating element.
3. Check the integrity of the cables and connections.

#### 7.2 Maintenance

We recommend a regular maintenance, including the following steps:

1. Check the free movement of the actuating element.
2. Remove particles of dust and soiling.
3. Check the integrity of the cables and connections.

**Damaged or defective components must be replaced.**

### 8. Disassembly and disposal



#### 8.1 Disassembly

The safety switchgear must be disassembled in a de-energised condition only.

#### 8.2 Disposal

The safety switchgear must be disposed of in an appropriate manner in accordance with the national prescriptions and legislations.

9.1 EC Declaration of conformity

	
<h2>EC Declaration of conformity</h2>	
Translation of the original declaration of conformity	K.A. Schmersal GmbH Industrielle Sicherheitssysteme Möddinghofe 30, 42279 Wuppertal Germany Internet: www.schmersal.com
We hereby certify that the hereafter described safety components both in its basic design and construction conform to the applicable European Directives.	
<b>Name of the safety component / type:</b>	Z/T 256 AS 2S
<b>Description of the safety component:</b>	Positive break position switch for safety functions with integrated AS-i Safety at Work
<b>Harmonised EC-Directives:</b>	2006/42/EC - EC-Machinery Directive 2004/108/EC - EMC-Directive
<b>Person authorized for the compilation of the technical documentation:</b>	Ulrich Loss Möddinghofe 30 42279 Wuppertal
<b>Place and date of issue:</b>	Wuppertal, 10. Dezember 2010
Z/T 256 AS 2S-A-EN	
	Authorised signature <b>Heinz Schmersal</b> Managing Director



The currently valid declaration of conformity can be downloaded from the internet at [www.schmersal.net](http://www.schmersal.net).



**K. A. Schmersal GmbH**  
**Industrielle Sicherheitssysteme**  
Möddinghofe 30, D - 42279 Wuppertal  
Postfach 24 02 63, D - 42232 Wuppertal

Telefon +49 - (0)2 02 - 64 74 - 0  
Telefax +49 - (0)2 02 - 64 74 - 1 00  
E-Mail: [info@schmersal.com](mailto:info@schmersal.com)  
Internet: <http://www.schmersal.com>