



**EN** Operating instructions. . . . .pages 1 to 8  
Translation of the original operating instructions

**Content**

**1 About this document**

1.1 Function . . . . . 1

1.2 Target group: authorised qualified personnel. . . . . 1

1.3 Explanation of the symbols used . . . . . 1

1.4 Appropriate use . . . . . 1

1.5 General safety instructions . . . . . 1

1.6 Warning about misuse . . . . . 1

1.7 Exclusion of liability . . . . . 2

**2 Product description**

2.1 Ordering code . . . . . 2

2.2 Special versions. . . . . 2

2.3 Destination and use . . . . . 2

2.4 Technical data . . . . . 2

**3 Mounting**

3.1 General mounting instructions . . . . . 2

3.2 Dimensions . . . . . 3

**4 Electrical connection**

4.1 General information for electrical connection. . . . . 5

4.2 Switch travel diagrams. . . . . 5

**5 Set-up and maintenance**

5.1 Functional testing. . . . . 6

5.2 Maintenance . . . . . 6

**6 Disassembly and disposal**

6.1 Disassembly. . . . . 6

6.2 Disposal. . . . . 6

**7 Appendix**

7.1 EC Declaration of conformity . . . . . 7

**1. About this document**

**1.1 Function**

This operating instructions manual provides all the information you need for the mounting, set-up and commissioning to ensure the safe operation and disassembly of the switchgear. The operating instructions must be available in a legible condition and a complete version in the vicinity of the device.

**1.2 Target group: authorised qualified personnel**

All operations described in this operating instructions manual must be carried out by trained specialist personnel, authorised by the plant operator only.

Please make sure that you have read and understood these operating instructions and that you know all applicable legislations regarding occupational safety and accident prevention prior to installation and putting the component into operation.

The machine builder must carefully select the harmonised standards to be complied with as well as other technical specifications for the selection, mounting and integration of the components.

**1.3 Explanation of the symbols used**



**Information, hint, note:**

This symbol is used for identifying useful additional information.



**Caution:** Failure to comply with this warning notice could lead to failures or malfunctions.

**Warning:** Failure to comply with this warning notice could lead to physical injury and/or damage to the machine.

**1.4 Appropriate use**

It is the responsibility of the manufacturer of a machine or plant to ensure the correct functionality of the entire machinery or plant.

The switch must be exclusively used in accordance with the versions listed below or for the applications authorised by the manufacturer. Detailed information regarding the range of applications can be found in the chapter "Product description".

**1.5 General safety instructions**

The user must observe the safety instructions in this operating instructions manual, the country-specific installation standards as well as all prevailing safety regulations and accident prevention rules.



Further technical information can be found in the Schmersal catalogues or in the online catalogue on the Internet: [www.schmersal.net](http://www.schmersal.net).

The information contained in this operating instructions manual is provided without liability and is subject to technical modifications.

There are no residual risks, provided that the safety instructions as well as the instructions regarding mounting, commissioning, operation and maintenance are observed.

**1.6 Warning about misuse**



In case of inadequate or improper use or manipulations of the component, personal hazards or damage to machinery or plant components cannot be excluded. The relevant requirements of the standard EN 1088 must be observed.

#### 1.7 Exclusion of liability

We shall accept no liability for damages and malfunctions resulting from defective mounting or failure to comply with this operating instructions manual. The manufacturer shall accept no liability for damages resulting from the use of unauthorised spare parts or accessories.

For safety reasons, invasive work on the device as well as arbitrary repairs, conversions and modifications to the device are strictly forbidden; the manufacturer shall accept no liability for damages resulting from such invasive work, arbitrary repairs, conversions and/or modifications to the device.

## 2. Product description

#### 2.1 Ordering code

This operating instructions manual applies to the following types:

##### EX-① 441-11Y-②-③-1276-2 Belt alignment- and slack-wire switches

No.	Option	Description
①	M.	Snap action
	T.	Slow action
②	UE	Slow action with overlapping contacts
③	Lever selection, refer to catalogue	

##### EX-① 441-11Y-②-1276-2 Position switches

No.	Option	Description
①	M.	Snap action
	T.	Slow action
②	UE	Slow action with overlapping contacts

Lever selection, refer to catalogue (to be ordered separately)



Only if the information described in this operating instructions manual are realised correctly, the compliance with the Explosion Protection Directive is maintained.

#### 2.2 Special versions

For special versions, which are not listed in the order code below 2.1, these specifications apply accordingly, provided that they correspond to the standard version.

#### 2.3 Destination and use

Belt alignment switches and slack-wire switches are suitable for use on material handling equipment. The belt alignment switch is actuated, when the conveyor belt becomes misaligned.

The slack-wire switch monitor the wire tension. If the wire is properly tensioned, the switch is actuated. Depending on the configuration of the plant, these signals can be used to switch off the plant or to provide for an automatic correction of the belt.

Position switches are used wherever moving parts on machinery and plants need to be positioned, controlled and monitored.

The components can be used in explosion-endangered areas of Zone 21 and 22 equipment category 2D and 3D. The installation and maintenance requirements to the standard series EN 60079 (ABNT NBR IEC 60079) must be met.

#### 2.4 Technical data

Equipment category:	⊕ II 2D
Ex protection:	Ex tb IIIC T90°C Db
INMETRO:	DNV 13.0076
Standards:	EN 60947-5-1, EN 60079-0, EN 60079-31, ABNT NBR IEC 60947-5-1, ABNT NBR IEC 60079-0, ABNT NBR IEC 60079-31
Enclosure:	Grey cast iron, galvanized and painted
Actuating speed:	max. 1 ms
Max. impact energy:	7 J
Max. surface temperature:	+90 °C
Protection class:	IP65, IP66 and IP67 to EN 60529 (ABNT NBR IEC 60529)
Contact material:	silver, gold-flashed
Switching system:	snap and slow action with double break
Contact type:	Snap action: change-over contact, Slow action: positive break NC contact ⊕; double break of 2 separated contact bridges
Connection:	screw terminals M 4
Cable section:	max. 2.5 mm <sup>2</sup> (incl. conductor ferrules)
Cable entry:	M20 × 1.5
U <sub>imp</sub> :	Snap action: 4 kV; Slow action: 6 kV
U <sub>i</sub> :	Snap action: 250 V; Slow action: 400 V
I <sub>the</sub> :	16 A
Utilisation category:	AC-15
I <sub>e</sub> /U <sub>e</sub> :	Snap action: 4 A / 230 V; Slow action: 4 A / 400 V
Max. fuse rating:	16 A gG D-fuse
Required short-circuit current:	1000 A
Contact break:	Snap action: max. 2 × 6.0 mm
Switchover time:	Snap action: 35 ms
Bounce duration:	Snap action: 5 ms
Ambient temperature:	-20 °C ... +60 °C
Mechanical life:	10 million operations
Switching frequency:	max. 3000 / h
Belt speed:	max. 30 km / h
Max. operating hours belt alignment switch lever:	25000 hours
Cable glands:	⊕ II 2GD, 1,21 ABNT NBR IEC 60079
Cable cross-section:	min. Ø 7 mm; max. Ø 12 mm
Tightening force:	Cable gland: 8 Nm Blocking screws: 8 Nm Cover screws: 1 Nm

## 3. Mounting

#### 3.1 General mounting instructions



Fitting is only authorised in a de-energised condition

Two mounting holes are available. The use of a protective ground wire is imperative.



Please observe the recommendations regarding maximum belt speed, operating hours, operating speed and tightening torque in the technical data.



Position switch T. 441-... / M. 441-...

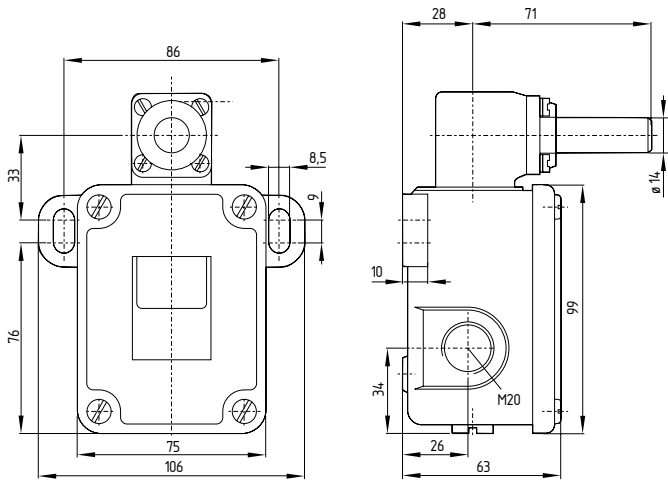

Roller lever L

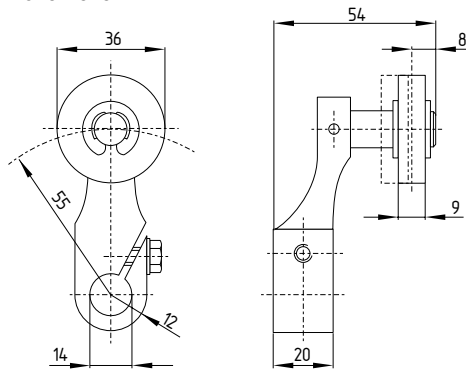

- Actuating speed max. 3 m/s, min. 0.05 m/s with an actuating angle of  $\alpha$  and  $\beta = 30^\circ$
- Continuous adjustment of lever position  $360^\circ$
- Splined shaft and lever available with  $10^\circ$  toothing

Roller lever V

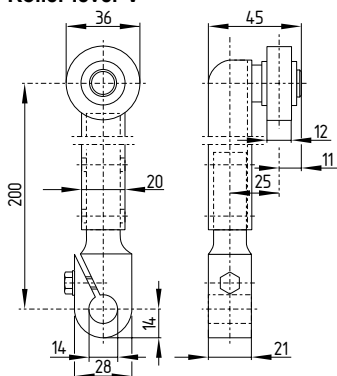

- Actuating speed max. 3 m/s, min. 0.05 m/s with an actuating angle of  $\alpha$  and  $\beta = 30^\circ$
- Continuous adjustment of lever position  $360^\circ$
- Splined shaft and lever available with  $10^\circ$  toothing

Fork lever C

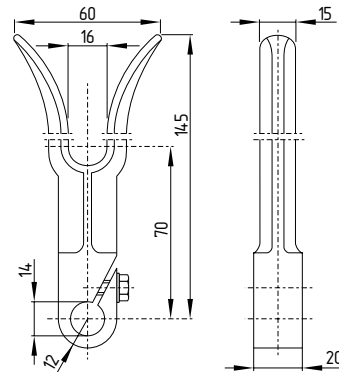

- Continuous adjustment of lever position  $360^\circ$
- Splined shaft and lever available with  $10^\circ$  toothing

Roller lever A

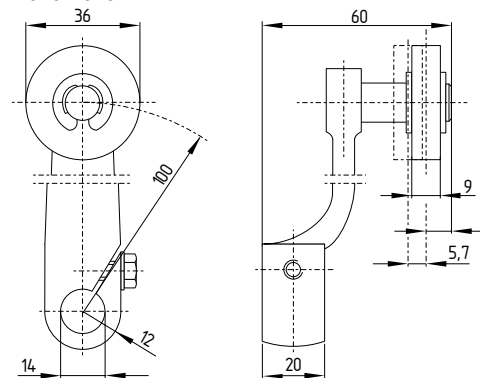

- Actuating speed max. 3 m/s, min. 0.05 m/s with an actuating angle of  $\alpha$  and  $\beta = 30^\circ$
- Continuous adjustment of lever position  $360^\circ$
- Splined shaft and lever available with  $10^\circ$  toothing

Pull lever Z

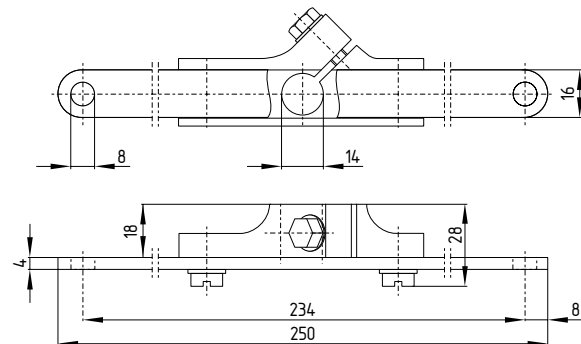

- Continuous adjustment of lever position  $360^\circ$
- Splined shaft and lever available with  $10^\circ$  toothing

Offset roller lever 4D

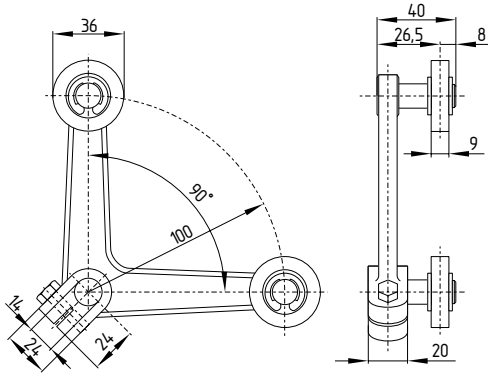

- Continuous adjustment of lever position 360°
- Splined shaft and lever available with 10° tothing

Roller lever 2A

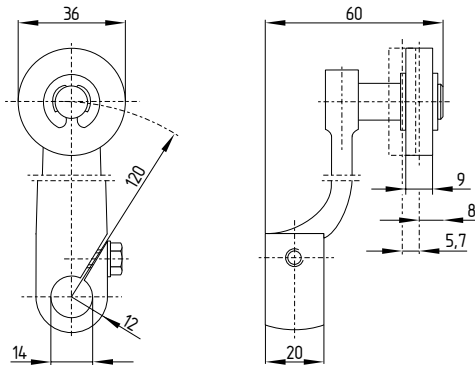

- Actuating speed max. 3 m/s, min. 0.05 m/s with an actuating angle of  $\alpha$  and  $\beta = 30^\circ$
- Continuous adjustment of lever position 360°
- Splined shaft and lever available with 10° tothing

Roller lever D

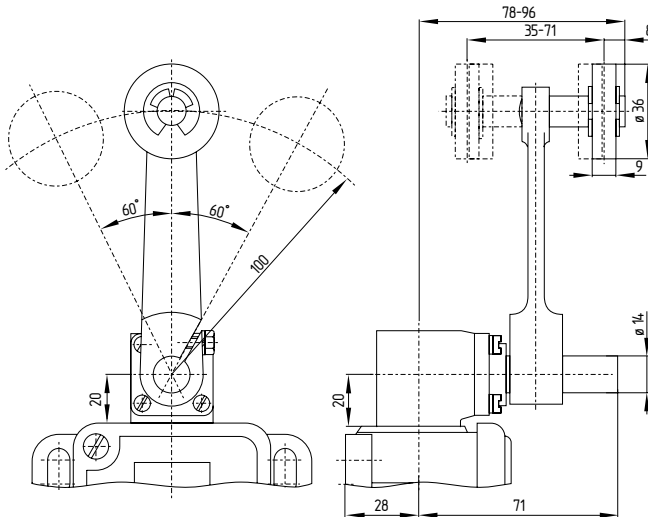

- Actuating speed max. 3 m/s with an actuating angle of  $\alpha$  and  $\beta = 30^\circ$
- in the temperature-resistant version, the roller can be fitted onto the shaft in 2 different poitions
- Continuous adjustment of lever position 360°
- 180° repositioning of the actuator head on the shaft
- Actuator head can be repositioned in steps 4 x 90°
- With metal roller available on request
- Splined shaft and lever available with tothing

Pull lever 2Z

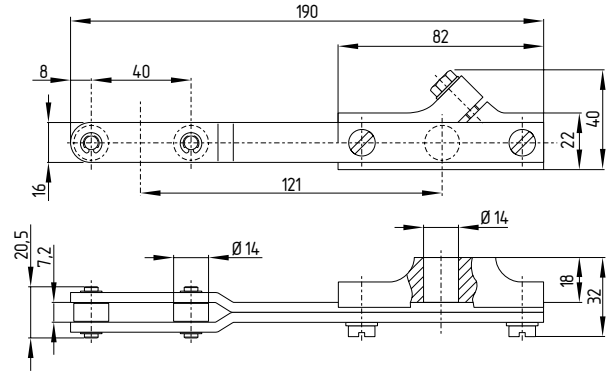

- Continuous adjustment of lever position 360°
- Splined shaft and lever available with 10° tothing

Legend

$\alpha$  = Actuating angle from right of switch axis  
 $\beta$  = Actuating angle from left of switch axis

4. Electrical connection

4.1 General information for electrical connection



The electrical connection may only be carried out by authorised personnel in a de-energised condition.

Only use cable glands which are authorised for the corresponding field of application. The cable glands must be fitted in accordance with the applicable operating instructions manual. Cable glands are only authorised for permanent cables. The constructor must provide for the necessary strain relief. Unused cable entries must be sealed by means of Ex approved locking screws. Cable glands and locking screws are not included in delivery. After wiring, the cover screws must be tightened uniformly. Tightening torque cover screws: 1 Nm.

4.2 Switch travel diagrams

Snap action

1 NO contact / 1 NC contact

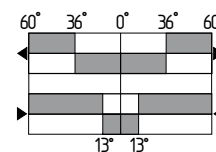

Slow action

1 NO contact / 1 NC contact

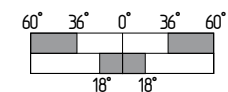

**5. Set-up and maintenance**

**5.1 Functional testing**

The function of the component must be tested. The following conditions must be previously checked and met.

1. The installation is executed according to the instructions
2. The connection is executed correctly
3. The cable is correctly executed and connected.
4. The component is not damaged
5. Check the free movement of the actuating element
6. Remove particles of dust and soiling
7. Check cable entry and connections in a de-energised condition

**5.2 Maintenance**

In case of correct installation in accordance with the above-described instructions, the component requires little maintenance. By use in extreme conditions, we recommend routine maintenance including the following steps:

1. Check the free movement of the actuating element
2. Remove particles of dust and soiling
3. Check the correct fixing of the cover screws
4. Check for damages and correct fixing
5. Check cable entry and connections in a de-energised condition
6. Lubricate the shaft or plunger (if necessary)



Do not open the device when live.

**Damaged or defective components must be replaced.**  
**For explosion protection reasons, the component must be exchanged after max. 10 million operations.**

**6. Disassembly and disposal**

**6.1 Disassembly**

The product must be disassembled in a de-energised condition only.

**6.2 Disposal**

The product must be disposed of in an appropriate manner in accordance with the national prescriptions and legislations.

7. Appendix

7.1 EC Declaration of conformity

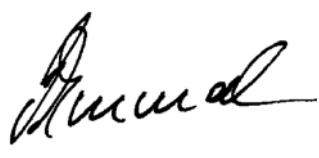
	
<h2>EC Declaration of conformity</h2>	
Translation of the original declaration of conformity	K.A. Schmersal GmbH & Co. KG Industrielle Sicherheitssysteme Mödinghofe 30, 42279 Wuppertal Germany Internet: www.schmersal.com
We hereby certify that the hereafter described products both in their basic design and construction conform to the applicable European Directives.	
<b>Name of the component / type:</b>	EX-T/M 441 ⊕ II 2D Ex tb IIIC T90°C Db
<b>Description of the component:</b>	Belt alignment switch / Slack-wire switch / Position switch
<b>Relevant EC-Directives:</b>	2006/95/EG EC Low Voltage Directive 94/9/EC EC-Explosion Protection Directive (ATEX)
<b>Used harmonized standards:</b>	EN 60079-0, EN 60079-31
<b>Person authorized for the compilation of the technical documentation:</b>	Oliver Wacker Mödinghofe 30 42279 Wuppertal
<b>Notified body, which approved the full quality assurance system, referred to in Appendix X, 94/9/EC:</b>	TÜV Rheinland Industrie Service GmbH Am Grauen Stein, 51105 Köln ID n°.: 0035, Certification-n°.: 01 220 4316/02
<b>Notified body:</b>	DEKRA EXAM GmbH Dinnendahlstraße 9, 44809 Bochum ID n°.: 0158
<b>EC-prototype test certificate:</b>	BVS 08 ATEX E 157
<b>Place and date of issue:</b>	Wuppertal, September 17, 2012
EX-T/M 441-C-EN	
	Authorised signature <b>Philip Schmersal</b> Managing Director



The currently valid declaration of conformity can be downloaded from the internet at [www.schmersal.net](http://www.schmersal.net).



**K. A. Schmersal GmbH & Co. KG**  
**Industrielle Sicherheitssysteme**  
Möddinghofe 30, D - 42279 Wuppertal  
Postfach 24 02 63, D - 42232 Wuppertal

Phone: +49 - (0)2 02 - 64 74 - 0  
Telefax +49 - (0)2 02 - 64 74 - 1 00  
E-Mail: [info@schmersal.com](mailto:info@schmersal.com)  
Internet: <http://www.schmersal.com>