



EN Operating instructions.pages 1 to 8
Translation of the original operating instructions

Content

1 About this document

1.1 Function 1

1.2 Target group: authorised qualified personnel. 1

1.3 Explanation of the symbols used 1

1.4 Appropriate use 1

1.5 General safety instructions 1

1.6 Warning about misuse 2

1.7 Exclusion of liability 2

2 Product description

2.1 Ordering code 2

2.2 Special versions. 2

2.3 Destination and use 2

2.4 Technical data 4

2.5 Safety classification 5

3 Mounting

3.1 General mounting instructions 5

3.2 Dimensions 5

4 Electrical connection

4.1 General information for electrical connection. 7

4.2 Contact variants. 7

5 Set-up and maintenance

5.1 Functional testing. 7

5.2 Maintenance 7

6 Disassembly and disposal

6.1 Disassembly. 7

6.2 Disposal 7

7 Appendix

7.1 EC Declaration of conformity 8

1. About this document

1.1 Function

This operating instructions manual provides all the information you need for the mounting, set-up and commissioning to ensure the safe operation and disassembly of the safety switchgear. The operating instructions must be available in a legible condition and a complete version in the vicinity of the device.

1.2 Target group: authorised qualified personnel

All operations described in this operating instructions manual must be carried out by trained specialist personnel, authorised by the plant operator only.

Please make sure that you have read and understood these operating instructions and that you know all applicable legislations regarding occupational safety and accident prevention prior to installation and putting the component into operation.

The machine builder must carefully select the harmonised standards to be complied with as well as other technical specifications for the selection, mounting and integration of the components.

1.3 Explanation of the symbols used



Information, hint, note:
This symbol is used for identifying useful additional information.



Caution: Failure to comply with this warning notice could lead to failures or malfunctions.
Warning: Failure to comply with this warning notice could lead to physical injury and/or damage to the machine.

1.4 Appropriate use

The products described in these operating instructions are developed to execute safety-related functions as part of an entire plant or machine. It is the responsibility of the manufacturer of a machine or plant to ensure the correct functionality of the entire machinery or plant.

The safety switchgear must be exclusively used in accordance with the versions listed below or for the applications authorised by the manufacturer. Detailed information regarding the range of applications can be found in the chapter "Product description".

1.5 General safety instructions

The user must observe the safety instructions in this operating instructions manual, the country-specific installation standards as well as all prevailing safety regulations and accident prevention rules.



Further technical information can be found in the Elan catalogues or in the online catalogue on the Internet: www.elan.de

The information contained in this operating instructions manual is provided without liability and is subject to technical modifications.



If multiple safety components are wired in series, the Performance Level to EN ISO 13849-1 will be reduced due to the restricted error detection under certain circumstances. The entire concept of the control system, in which the safety component is integrated, must be validated to EN ISO 13849-2.

There are no residual risks, provided that the safety instructions as well as the instructions regarding mounting, commissioning, operation and maintenance are observed.

1.6 Warning about misuse



In case of inadequate or improper use or manipulations of the safety switchgear, personal hazards or damage to machinery or plant components cannot be excluded. The relevant requirements of the standard EN 1088 must be observed.

1.7 Exclusion of liability

We shall accept no liability for damages and malfunctions resulting from defective mounting or failure to comply with this operating instructions manual. The manufacturer shall accept no liability for damages resulting from the use of unauthorised spare parts or accessories.

For safety reasons, invasive work on the device as well as arbitrary repairs, conversions and modifications to the device are strictly forbidden; the manufacturer shall accept no liability for damages resulting from such invasive work, arbitrary repairs, conversions and/or modifications to the device.

2. Product description

2.1 Ordering code

This operating instructions manual applies to the following types:

Interlocking device SHGV^{①/②③④/⑤/⑥+⑦}

No.	Option	Description
①		Default locking system
	-Z	Central locking system
②	B	Lock barrel at the bottom
	L	Lock barrel to left
	R	Lock barrel to the right
③	D	Additional lock barrel (front)
④	01	with one actuating head
	1.1	with two actuating heads for double-leaf doors
⑤	...	Key number
⑥	...	Key number of the additional lock barrel
⑦	BO	Straight actuator
	BOW	Angled actuator
	BOR	Radius actuator
	BOWR	Angled radius actuator
	BOF/HIS.1	Telescopic actuator, rearside fixing.
	BOF/HIS.2	Telescopic actuator, topside fixing.

key-operated selector switch SHGV^{①/ESS21S2/②/103}

No.	Option	Description
①		Default locking system
②	-Z	Central locking system
	...	Key number

Key-operated selector switch-interlocking device SVE^{①②/③-④⑤}

No.	Option	Description
①	1	1 key-operated selector switches
	2	2 key-operated selector switches
	3	3 key-operated selector switches
②		Default locking system
	-Z	Central locking system
③	...	Key number(s)
④		Magnet: 1 NC/1 NO contact
		Key-operated selector switch: 1 NC contacts/1 NO contact
		NC contacts in series
3Ö		Magnet: 1 NC/1 NO contact
		Key-operated selector switch: 2 NC contacts/1 NO contact
		NC contacts in series
W		Magnet: 1 NC/1 NO contact
		Key-operated selector switch: 2 NC contacts/1 NO contact
		NC contacts separately
⑤		U _s 24 VDC
	24 VAC	U _s 24 VAC
	115 VAC	U _s 115 VAC
	230 VAC	U _s 230 VAC

Key distribution station SVM^{①/②-③/④/⑤}

No.	Option	Description
①		Default locking system
	-Z	Central locking system
②	...	Key number primary key
③	6	6 secondary keys
	10	10 secondary keys
④	...	Key number secondary key
⑤	E	Plate for flush mounting
	A	Enclosure for surface mounting

Not all component variants, which are possible according to this order code, are available.



Only if the information described in this operating instructions manual are realised correctly, the safety function and therefore the compliance with the Machinery Directive is maintained.

2.2 Special versions

For special versions, which are not listed in the order code below 2.1, these specifications apply accordingly, provided that they correspond to the standard version.

2.3 Destination and use

The trapped key system, consisting of the components SHGV..., SHGV/ESS... and SVM..., has been designed to prevent, in conjunction with the control part of the machine, movable safety guards from being opened before hazardous conditions have been eliminated.

By turning the key-operated selector switch from the trapped position into the removable position, the NC contacts are positively opened and the NO contacts closed.



This combination can only be used for applications, in which the hazardous situation is eliminated without delay (e.g. run-on movements) after the switch-off command from the key-operated selector switch.

The trapped key system, consisting of the components SHGV..., SVE... and SVM..., has been designed to prevent, in conjunction with the control part of the machine, movable safety guards from being opened before hazardous conditions have been eliminated. If the control part of the machine transmits a signal to the SVE... that the hazardous situation has been eliminated, the key can be withdrawn from the SVE..., as a result of which the movable safety guard can be opened.



If a delay device (e.g. timer) is used to by-pass the stopping time, a failure of this device must not cause the delay time to be reduced.

The user must evaluate and design the safety chain in accordance with the relevant standards and on the required safety level.



Please implement the necessary organisational measures to ensure that only one main key is in use for each system. The user imperatively must ensure that a key number (coding) is only used just once in every plant (factory premises).

Key-operated selector switch SHGV/ESS...

In position (1), the key is trapped and cannot be withdrawn. The NC contact(s) is/are closed. The NO contact(s) is/are opened. By turning the key into position (2), the NC contact(s) is/are positively opened and the NO contact(s) closed. In this position, the key can be withdrawn.

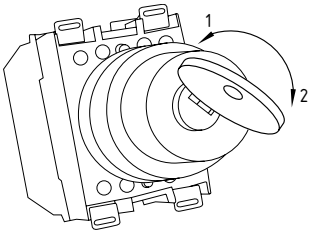

Key-operated selector switch-interlocking device SVE...

In position (1), the key(s) is/are trapped and cannot be withdrawn. The NC contacts of the key-operated selector switch are closed. The NO contacts are open. The NC contact of the magnet monitoring is closed and the NO contact is open. If the magnet is in de-energised condition, the keys cannot be turned and withdrawn. If the magnet is energised, it will unlock the key-operated selector switch. The NC contact of the magnet monitoring is opened and the NO contact closed. After the keys are turned into position (2), they can be withdrawn. In this position, the NC contacts of the key-operated selector switch are positively opened and the NO contacts closed. In this key position, the solenoid cannot switch to the "locked" position when the voltage supply is switched off.

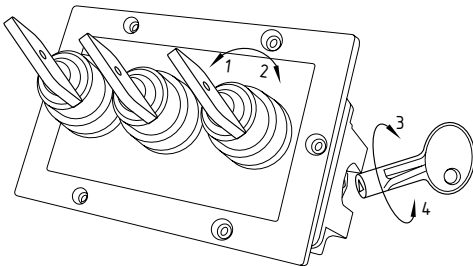

Manual release (during set-up, maintenance, etc.) The manual release is realised by turning the triangular key (included in delivery) to the right (3), so that the solenoid is pulled into the release position. The normal locking function is only restored after the triangular key has been returned to its original position (4). The manual release must be sealed after being put into operation (e.g. sealant etc.).

Key distribution station SVM1...

In position (1), the primary key can be withdrawn. When the primary key is removable, the secondary keys can only be in position (3) and will be trapped (i.e. cannot be withdrawn). If the primary key is turned into position (2), the secondary keys can be turned into position (4) and be withdrawn. If one or more secondary keys are in position (4) either removed, the primary key cannot be withdrawn. The primary key is coming either from a SHGV/ESS... key-operated selector switch or a SVE... key-operated selector switch interlocking device. Multiple SHGV... interlocking devices can be unlocked by means of the secondary keys.

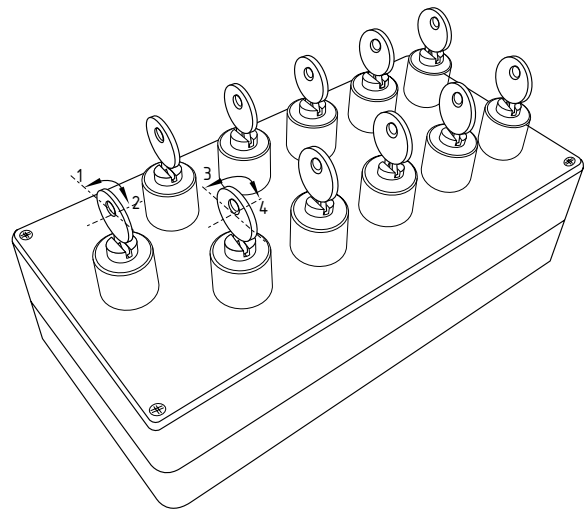

Interlocking device with key tumbler cylinder SHGV/L01/...; SHGV/R01/...; SHGV/B01/...

Insert the key from a SHGV/ESS..., SVE... or SVM... in the key tumbler cylinder (1) and turn it into position (2). The interlocking device is unlocked, the safety guard can be opened. The key can only be returned into position (3) and withdrawn, when the safety guard is closed.

SHGV/L01...

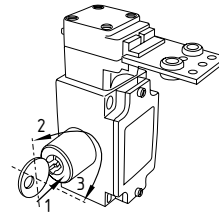

SHGV/R01...

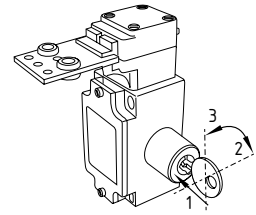

SHGV/B01...

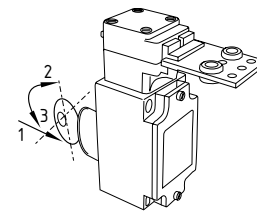

If on the basis of the risk assessment it cannot be excluded that persons are trapped inside the hazardous area, the interlocking device with 2 lock barrels must be used.

Interlocking device with two key tumbler cylinders SHGV/LD1/...; SHGV/RD1/...

Insert the key from a SHGV/ESS..., SVE... or SVM... in the key tumbler cylinder (1) and turn it into position (3). The interlocking device is unlocked, the safety guard can be opened. In this position, the second key (6) can be turned from position (4) into position (5) and withdrawn. The guard door cannot be locked by means of key (1) as long as the key (6) is inserted in the key tumbler cylinder and turned into position (4). The key (1) can only be returned to position (2) and withdrawn, if the key (6) is in position (4) and the safety guard is closed.

SHGV/LD1...

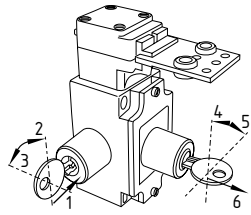

SHGV/RD1...

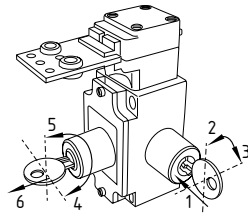

Interlocking device with two actuators

SHGV/L1.1/...; SHGV/R1.1/...; SHGV/B1.1/...

Insert the key from a SHGV/ESS..., SVE... or SVM... in the key tumbler cylinder (1) and turn it into position (2). The interlocking device is unlocked, both safety guards can be opened. The key can only be returned to position (3) and withdrawn, when both safety guards are closed.

SHGV/L1.1...

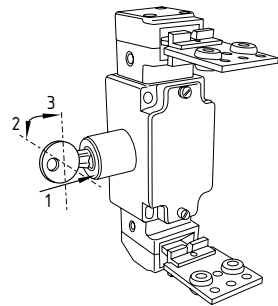

SHGV/R1.1...

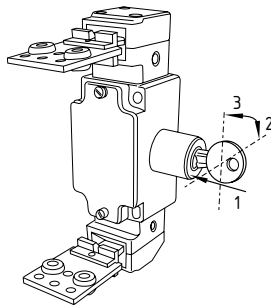

SHGV/B1.1...

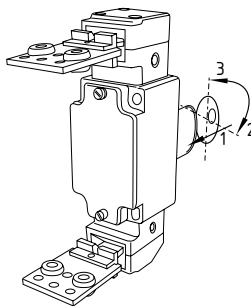

2.4 Technical data

Interlocking device:

Standards:	IEC 60947-5-1; EN ISO 13849-1; EN 1088
enclosure / cover:	Aluminium / chromated steel
Actuator and locking bolt:	Galvanised steel / zinc die-cast
Protection class:	IP65
Ambient temperature:	-25 °C ... +70 °C
Betätigungsgeschwindigkeit:	0.2 m/s
Actuating frequency:	max. 5/h
Mechanical life:	100.000 operations
F_{max} :	1.250 N; SHGV/B...: 1.750 N
Latching force:	5 N

Key-operated selector switch:

Standards:	IEC 60947-5-1, IEC 60947-5-5, IEC 60947-1, EN ISO 13850
Installation diameter:	22,3 mm
Front plate thickness:	1 ... 6 mm
Mounting position:	random
Ambient temperature:	-25 °C ... +75 °C
Protection class:	IP65
Front ring material:	Aluminium anodised
Mounting:	with mounting flange
Max. tightening torque for the ELM fixing screws:	0,6 Nm
Actuating frequency:	max. 5/h
Mechanical life:	100.000 operations

Contact elements:

Standards:	IEC/EN 60947-5-1
Contact material:	Silver
Protection class:	Wiring level: IP20 Wiring compartment: IP40
Contact type:	Change-over with double break Zb, galvanically separated contact bridges
Switching system:	⊖ IEC 60947-5-1; slow action, NC contact with positive break
Termination:	Screw terminals
Cable type:	solid wire
Cable section:	max. 2 × 0.5 ... 2.5 mm ²
Cable type:	solid and stranded wire
Cable section:	max. 2 × 0,5 ... 1,5 mm ² with conductor ferrules
positive break travel:	approx. 2 mm after the opening point
Mechanical life:	10 million operations
Ambient temperature:	-25 °C ... +50 °C
Utilisation category:	AC-15, DC-13
I_e / U_e :	8 A / 230 VAC; 5 A / 24 VDC
U_j :	400 V
U_{imp} :	4 kV
I_{the} :	10 A
Max. fuse rating:	10 A gG D-fuse to EN 60269-1

Key-operated selector switch-interlocking device:

Standards:	IEC 60947-5-1, EN ISO 13849-1, EN 1088
Enclosure:	glass-fibre reinforced thermoplastic, self-extinguishing
Latching bolt:	Plastic
Contact material:	Silver
Protection class:	IP65
Contact type:	Change-over with double break Zb, galvanically separated contact bridges
Switching system:	⊖ IEC 60947-5-1; slow action, NC contact with positive break
termination:	Connector plug with screw terminals
Cable type:	solid wire
Cable section:	0.2 ... 2.5 mm ²
Cable type:	solid and stranded wire
Cable section:	0.2 ... 2.5 mm ² with conductor ferrules
U_{imp} :	2.5 kV
U_j :	250 V
I_{the} :	4 A
Utilisation category:	AC-15, DC-13
I_e / U_e :	4 A / 230 VAC; 4 A / 24 VDC
Max. fuse rating:	4 A gG D-fuse to EN 60269-1
Positive break travel (unlocked):	2 × 3,5 mm
Positive break force (unlocked):	20 N
Magnet:	100% ED
U_s :	24 VDC, 110 VAC: 50 / 60 Hz; 230 VAC: 50 / 60 Hz

Power consumption:	max. 8.5 W
Ambient temperature:	0 °C ... +50 °C
Actuating frequency:	max. 5/h
Mechanical life:	100.000 operations

Key distribution station:

Standards:	EN ISO 13849-1, EN 1088
enclosure:	Design .../A: Aluminium
Front plate:	Design .../E: Stainless steel
Latching bolt:	Brass
Protection class:	IP65 (SVM1.../A IP40 (SVM1.../E
Ambient temperature:	-25 °C ... +50 °C
Actuating frequency:	max. 5/h
Mechanical life:	100.000 operations

2.5 Safety classification

Interlocking device (type 2):

Standards:	EN ISO 13849-1
MTTF _d :	150 years; when a single switch is used, suitable up to PL d (when used in PL d, fault exclusions must be guaranteed)

B _{10d} :	100.000
Service life:	20 years

Key-operated selector switch:

Standards:	EN ISO 13849-1
B _{10d} (NC contact):	100.000
Service life:	20 years

Key-operated selector switch-interlocking device SVE:

Standards:	EN ISO 13849-1
B _{10d} (NC contact):	100.000
Service life:	20 years

Key distribution station:

Standards:	EN ISO 13849-1
B _{10d} :	100.000
Service life:	20 years

$$MTTF_d = \frac{B_{10d}}{0,1 \times n_{op}} \quad n_{op} = \frac{d_{op} \times h_{op} \times 3600 \text{ s/h}}{t_{cycle}}$$

(Specifications can vary depending on the application-specific parameters hop, dop and tcycle as well as the load.)

3. Mounting

3.1 General mounting instructions

Interlocking device

Four mounting holes are provided for fixing the interlock. When used in applications with function for the protection of man, the components must be fitted so that disassembly is prevented (e.g. drill out the hexagonal recess of the fixing screws, blocking the hexagonal recess using a plastic cone).

The solenoid interlock must not be used as an end stop. Any mounting position. The mounting position must be chosen so as to avoid the penetration of dirt in the used holes. For the lock barrel, the SHGV-SK dust-proof flap (accessory) can be used as required.

In case of painting activities, the components must be covered. If another actuating direction is desired, the four screws of the actuating head must be loosened. Turn the actuating head in the desired direction and retighten the screws (tightening torque 0.5 Nm). The default screws installed in the actuating head can be replaced with the supplied tamperproof screws. The actuator must be inserted when the actuating head is turned.

Key-operated selector switch

Mount the key-operated selector switch in the provided mounting hole Ø 22.3 by means of the mounting flange, align and tighten. (tightening torque: 0.6 Nm). Snap the contact elements onto the mounting flange. Check for a correct and firm fixing of the elements. Any mounting position. The mounting position however must be chosen so that the ingress of dirt and soiling in the lock barrel is avoided. Use the SHGV-SK dust-proof flap (accessory) if necessary.

key-operated selector switch-interlocking device

Six mounting holes are provided for fixing the device. When used in applications with function for the protection of man, the components must be fitted so that disassembly is prevented. Any mounting position. The mounting position however must be chosen so that the ingress of dirt and soiling in the lock barrel is avoided, use the SHGV-SK dust-proof flap (accessory) if necessary. In case of painting activities, the components must be covered.

Key distribution station

Four mounting holes are provided for fixing the device. When used in applications with function for the protection of man, the components must be fitted so that disassembly is prevented. Any mounting position. The mounting position however must be chosen so that the ingress of dirt and soiling in the lock barrel is avoided, use the SHGV-SK dust-proof flap (accessory) if necessary. In case of painting activities, the components must be covered.



Please observe the remarks of the standards EN ISO 12100, EN 953 and EN 1088.

3.2 Dimensions

All measurements in mm.

Interlocking device

SHGV/R01/...; SHGV/L01/...; SHGV/B01/...

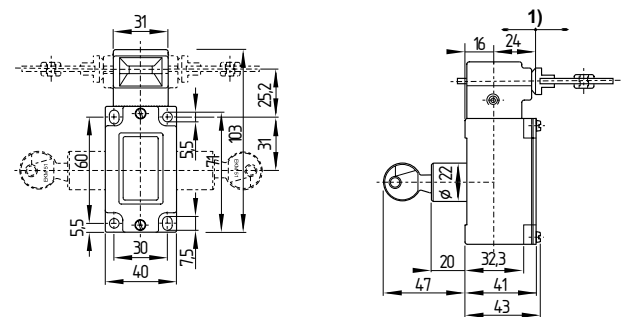

SHGV/RD1/...; SHGV/LD1/...

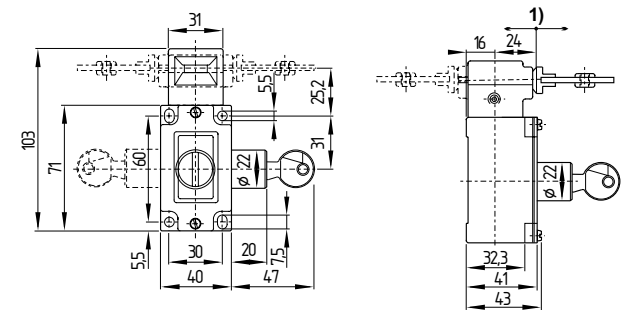

SHGV/R1.1/...; SHGV/L1.1/...; SHGV/B1.1/...

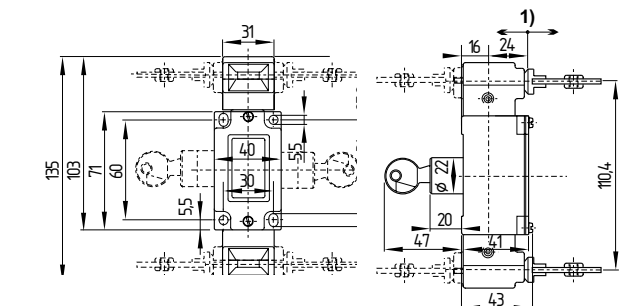

Key-operated selector switch

SHGV/ESS21S2/.../103

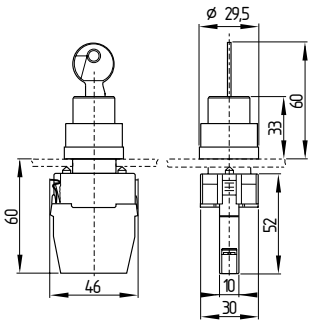

Key-operated selector switch-interlocking device

SVE.....

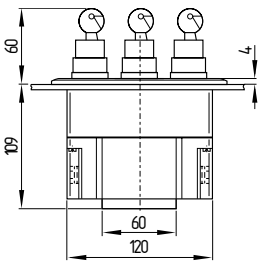
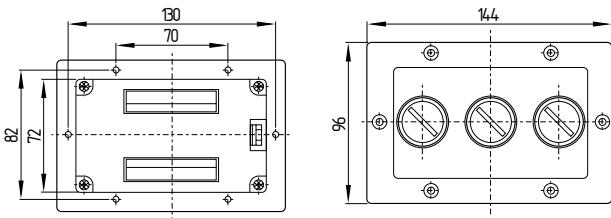

Key distribution station

SVM1/...-6/.../E

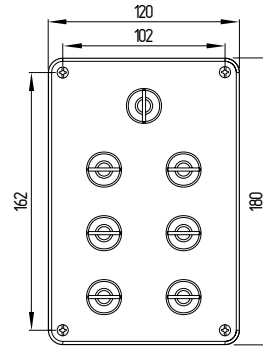
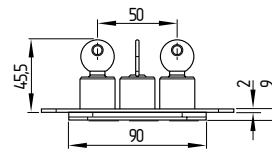

SVM1/...-10/.../E

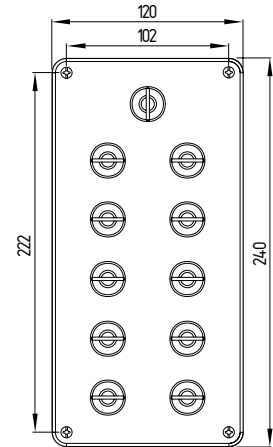
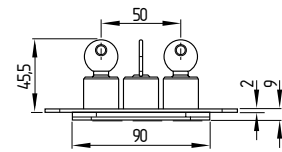

SVM1/...-6/.../A

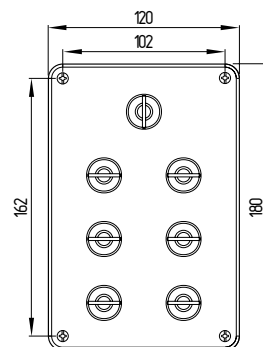
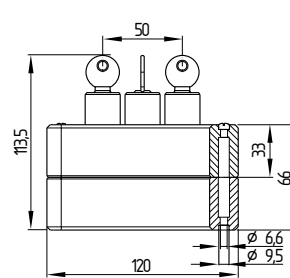

SVM1/...-10/.../A

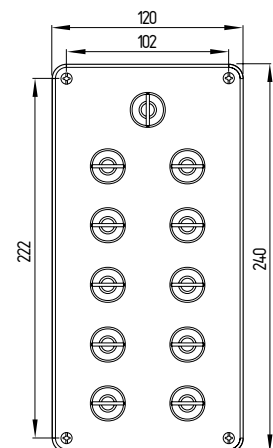
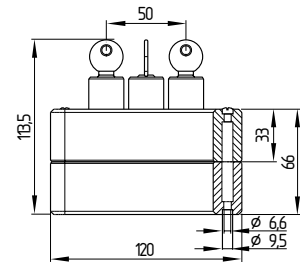

4. Electrical connection

4.1 General information for electrical connection



The electrical connection may only be carried out by authorised personnel in a de-energised condition. At least one positive-break contact of the key-operated selector switch or one positive-break contact of the solenoid monitoring of the key-operated selector switch-interlocking device must be integrated in the safety circuit.

After wiring, the wiring compartment must be cleaned (i.e. remove excess cables etc.).

4.2 Contact variants

Key-operated selector switch

The contacts are shown with the key-operated selector switch in a non-actuated condition and the key in unremovable condition.

SHGV/ESS21S2/.../103

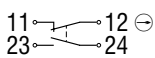

key-operated selector switch-interlocking device

The contacts are shown with the key-operated selector switch in a non-actuated condition, the key in unremovable condition and the solenoid in de-energised condition.

SVE.../...

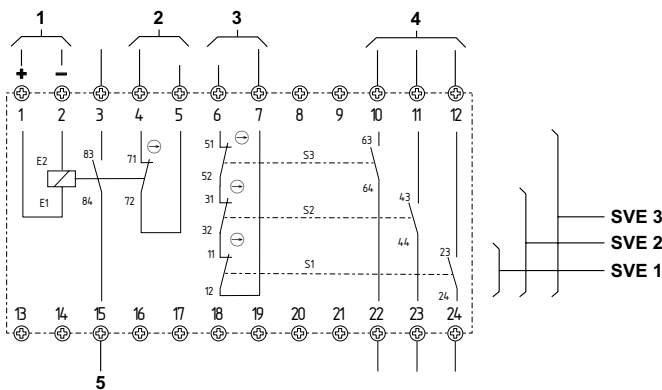

SVE.../.../3Ö..

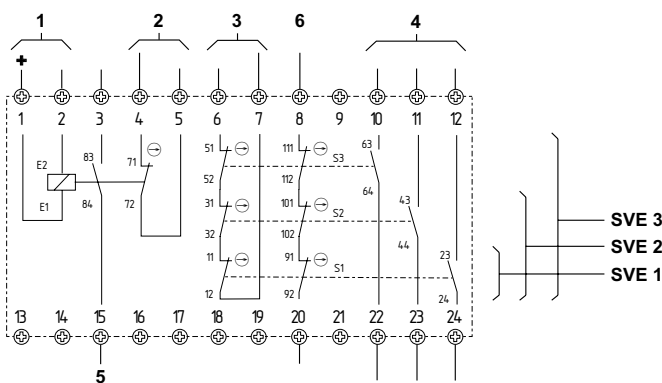

SVE.../.../W..

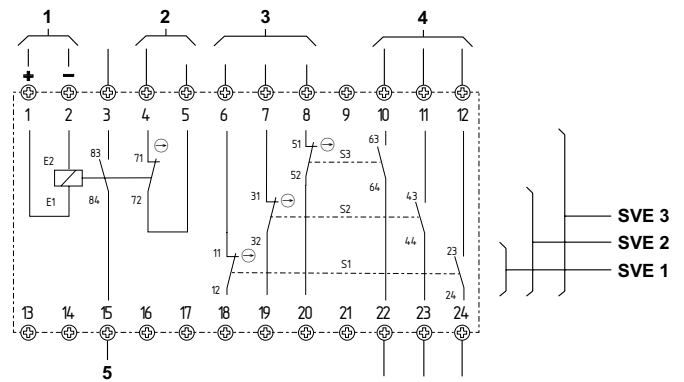

Legend

- ⊖ Positive break
- Ⓢ Solenoid connection
- ② Enabling circuit solenoid monitoring
- ③ Enabling circuit key-operated selector switch channel 1
- ④ Auxiliary contacts key-operated selector switch
- ⑤ Auxiliary contact solenoid
- ⑥ Enabling circuit key-operated selector switch channel 2

5. Set-up and maintenance

5.1 Functional testing

The safety function of the safety components must be tested. The following conditions must be previously checked and met:

1. Fitting of the solenoid interlock and the actuator.
2. Check the integrity of the cable entry and connections.
3. Check the switch enclosure for damage.

5.2 Maintenance

We recommend a regular visual inspection and functional test, including the following steps:

1. Check for tight installation of the actuator and the switch.
2. Remove particles of dust and soiling.
3. Check cable entry and connections.

Damaged or defective components must be replaced.

6. Disassembly and disposal

6.1 Disassembly

The safety switchgear must be disassembled in a de-energised condition only.

6.2 Disposal

The safety switchgear must be disposed of in an appropriate manner in accordance with the national prescriptions and legislations.

7.1 EC Declaration of conformity

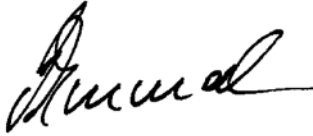
	
EC Declaration of conformity	
Translation of the original declaration of conformity	K.A. Schmersal GmbH & Co. KG Industrielle Sicherheitssysteme Mödinghofe 30, 42279 Wuppertal Germany Internet: www.schmersal.com
We hereby certify that the hereafter described safety components both in its basic design and construction conform to the applicable European Directives.	
Name of the safety component:	SHGV/SVE/SVM
Type:	Refer to 2.1 Ordering code
Description of the safety component:	Interlocking device with electromagnetic interlock for safety functions
Harmonised EC-Directives:	2006/42/EC-EC-Machinery Directive
Person authorized for the compilation of the technical documentation:	Oliver Wacker Mödinghofe 30 42279 Wuppertal
Notified body, which approved the full quality assurance system, referred to in Appendix X, 2006/42/EC:	TÜV Rheinland Industrie Service GmbH Alboinstraße 56 12103 Berlin ID n°: 0035
Place and date of issue:	Wuppertal, October 31, 2012
SHGV_SVE_SVM-C-EN	
	Authorised signature Philip Schmersal Managing Director



The currently valid declaration of conformity can be downloaded from the internet at www.schmersal.net.



K. A. Schmersal GmbH & Co. KG
Industrielle Sicherheitssysteme
Mödinghofe 30, D - 42279 Wuppertal
Postfach 24 02 63, D - 42232 Wuppertal

Phone: +49 - (0)2 02 - 64 74 - 0
Telefax +49 - (0)2 02 - 64 74 - 1 00
E-Mail: info@schmersal.com
Internet: <http://www.schmersal.com>