



SCHMERSAL

Version 2.0

EN Operating instructions. pages 1 to 20
Translation of the original operating instructions

Content

1 About this document

1.1 Function. 1

1.2 Target group: authorised qualified personnel 1

1.3 Explanation of the symbols used. 2

1.4 Appropriate use. 2

1.5 General safety instructions 2

1.6 Warning about misuse. 2

1.7 Exclusion of liability 2

2 Product description

2.1 Ordering code 2

2.1.1 Safety light curtain (Standard). 2

2.1.2 Safety light grid (Standard) 2

2.1.3 Safety light curtain (IP69K) 2

2.1.4 Safety light grid (IP69K) 2

2.2 Special versions 3

2.3 Included in delivery 3

2.3.1 Included in delivery of SLC/SLG 420 Standard. 3

2.3.2 Included in delivery of SLC/SLG 420 IP69K 3

2.4 Destination and use. 3

2.5 Technical data 3

2.5.1 Technical data IP69K (additions). 3

2.6 Response time (reaction time) 4

2.7 Effective resolution 4

2.8 Safety classification. 5

2.9 Functions. 5

2.9.1 Protective mode 5

2.9.2 Restart interlock (manual reset) 5

2.9.3 Fixed blanking SLC 420 5

2.9.4 Floating blanking SLC 420 6

2.9.5 Floating blanking SLG 420 6

2.9.6 Contactor control (EDM). 6

2.9.7 Start interlock 7

2.10 Self-test. 7

2.11 Beam coding A. 7

3 Mounting

3.1 General conditions 7

3.2 Protection field and approach 7

3.3 Alignment 8

3.4 Setting mode 8

3.5 Safety distance 8

3.5.1 Minimum distance to reflecting surfaces. 11

3.6 Dimensions 12

3.6.1 Dimensions transmitter and receiver SLC 420 (Standard) 12

3.6.2 Dimensions transmitter and receiver SLG 420 (Standard) 12

3.6.3 Dimensions transmitter and receiver SLC 420 IP69K. 13

3.6.4 Dimensions transmitter and receiver SLG 420 IP69K. 13

3.7 Scope of delivery and accessories 14

3.7.1 Included in delivery 14

3.7.2 Optional accessories. 14

4 Electrical connection

4.1 Wiring example default. 15

4.2 Activation of the contactor control (EDM) without PC software. . 16

4.3 Connector configuration Receiver, Transmitter & Cable 16

5 Set-up and maintenance

5.1 Check before start-up 17

5.2 Maintenance 17

5.3 Regular check 17

5.4 Half-yearly inspection 17

5.5 Cleaning 17

6 Diagnostic

6.1 LED status information 18

6.2 Fault diagnostic. 19

6.3 Extended diagnostic 19

7 Disassembly and disposal

7.1 Disassembly 19

7.2 Disposal. 19

8 Appendix

8.1 Contact 19

8.2 EC Declaration of conformity. 20

1. About this document

1.1 Function

This operating instructions manual provides all the information you need for the mounting, set-up and commissioning to ensure the safe operation and disassembly of the safety switchgear. The operating instructions must be available in a legible condition and a complete version in the vicinity of the device.

1.2 Target group: authorised qualified personnel

All operations described in this operating instructions manual must be carried out by trained specialist personnel, authorised by the plant operator only.

Please make sure that you have read and understood these operating instructions and that you know all applicable legislations regarding occupational safety and accident prevention prior to installation and putting the component into operation.

The machine builder must carefully select the harmonised standards to be complied with as well as other technical specifications for the selection, mounting and integration of the components.

1.3 Explanation of the symbols used



Information, hint, note:

This symbol is used for identifying useful additional information.



Caution: Failure to comply with this warning notice could lead to failures or malfunctions.

Warning: Failure to comply with this warning notice could lead to physical injury and/or damage to the machine.

1.4 Appropriate use

The products described in these operating instructions are developed to execute safety-related functions as part of an entire plant or machine. It is the responsibility of the manufacturer of a machine or plant to ensure the correct functionality of the entire machinery or plant.

The safety switchgear must be exclusively used in accordance with the versions listed below or for the applications authorised by the manufacturer. Detailed information regarding the range of applications can be found in the chapter "Product description".

1.5 General safety instructions

The user must observe the safety instructions in this operating instructions manual, the country-specific installation standards as well as all prevailing safety regulations and accident prevention rules.



Further technical information can be found in the Schmersal catalogues or in the online catalogue on the Internet: www.schmersal.net.

The information contained in this operating instructions manual is provided without liability and is subject to technical modifications.



The entire concept of the control system, in which the safety component is integrated, must be validated to EN ISO 13849-2.

There are no residual risks, provided that the safety instructions as well as the instructions regarding mounting, commissioning, operation and maintenance are observed.

Additional measures could be required to ensure that the electro-sensitive device does not present a dangerous breakdown, when other forms of light beams are available in a special application (e.g. use of wireless control devices on cranes, radiation of welding sparks or effects of stroboscopic lights).

1.6 Warning about misuse



In case of improper use or manipulation of the safety switchgear, personal hazards or damages to machinery or plant components cannot be excluded when safety switchgear is used. The relevant requirements of the standard EN ISO 13855 must be observed.



Only if the information described in this operating instructions manual are realised correctly, the safety function and therefore the compliance with the Machinery Directive is maintained.

1.7 Exclusion of liability

We shall accept no liability for damages and malfunctions resulting from defective mounting or failure to comply with this operating instructions manual. The manufacturer shall accept no liability for damages resulting from the use of unauthorised spare parts or accessories.

For safety reasons, invasive work on the device as well as arbitrary repairs, conversions and modifications to the device are strictly forbidden; the manufacturer shall accept no liability for damages resulting from such invasive work, arbitrary repairs, conversions and/or modifications to the device.

2. Product description

2.1 Ordering code

This operating instructions manual applies to the following types:

2.1.1 Safety light curtain (Standard)

SLC420-E/R①-②-RFB-③

No.	Option	Description
①	xxxx	Protection field heights in mm available lengths: 0170, 0250, 0330, 0410, 0490, 0570, 0650, 0730, 0810, 0890, 0970, 1050, 1130, 1210, 1290, 1370, 1450, 1530*, 1610*, 1690*, 1770*
②	14	Resolution 14 mm
	30	Resolution 30 mm
	50	Resolution 50 mm
③		Range 0.3 m ... 7 m only for resolution 14 mm
		Range 0.3 m ... 10 m only for resolution 30 and 50 mm
	H	Range 0.3 m ... 18 m, High Range only for resolution 30 mm

Note

* Protection field heights from 1530 to 1770 mm only with resolution of 30 and 50 mm

2.1.2 Safety light grid (Standard)

SLG420-E/R①-RF-②

No.	Option	Description
①	0500-02	Distance between outermost beams: 500 mm, 2-beam
	0800-03	800 mm, 3-beam
	0900-04	900 mm, 4-beam
②		Range 0,3 m ... 18 m
	H	Range 8 m ... 50 m, High Range

2.1.3 Safety light curtain (IP69K)

SLC420-E/R①-②-69-RFB

No.	Option	Description
①	xxxx	Protection field heights in mm available lengths: 0170, 0250, 0330, 0410, 0490, 0570, 0650, 0730, 0810, 0890, 0970, 1050, 1130, 1210, 1290, 1370, 1450
②	14	Resolution 14 mm with a range of 0.3 m ... 7 m
	30	Resolution 30 mm with a range of 0.3 m ... 10 m

2.1.4 Safety light grid (IP69K)

SLG420-E/R①-69-RF

No.	Option	Description
①	0500-02	Distance between outermost beams: 500 mm, 2-beam
	0800-03	800 mm, 3-beam
	0900-04	900 mm, 4-beam
		Range 0,3 m ... 18 m

2.2 Special versions

For special versions, which are not listed in the order code below 2.1, these specifications apply accordingly, provided that they correspond to the standard version.

2.3 Included in delivery

2.3.1 Included in delivery of SLC/SLG 420 Standard

- Sensors E, R
- Mounting kit MS-1030
- Test rod
- Operating instructions DE/EN

2.3.2 Included in delivery of SLC/SLG 420 IP69K

- Sensors E, R
- Mounting kit MS-1038
- 5 m long connection cable, permanently integrated on the transmitter and receiver
- Test rod
- Operating instructions DE/EN

2.4 Destination and use

The SLC 420 is a non-contact, self-testing safety guard, which is used for the protection of hazardous points, hazardous areas and machine accesses. If one or more light beams are interrupted, the hazardous movement must be stopped.



The user must evaluate and design the safety chain in accordance with the relevant standards and the required safety level.

2.5 Technical data

Standards:	EN 61496-1; EN 61496-2; EN ISO 13849; EN 62061
Material of the enclosure:	Aluminium
Number of beams:	2 ... 144 beams
Protection field heights:	
- SLC 420 with resolution 14 mm:	170 mm ... 1450 mm,
- SLC 420 with resolution 30 mm:	170 mm ... 1770 mm,
- SLC 420 with resolution 50 mm:	170 mm ... 1770 mm,
- SLG 420:	500 mm, 800 mm, 900 mm
Detection ability for test rod:	
- SLC 420:	14 mm, 30 mm, 50 mm
- SLG 420:	2 beams with resolution 500 mm ¹⁾ 3 beams with resolution 400 mm ¹⁾ 4 beams with resolution 300 mm ¹⁾
Range of the protection field:	
- SLC 420 with resolution 14 mm:	0.3 ... 7.0 m
- SLC 420 with resolution 30 and 50 mm:	0.3 ... 10.0 m
- SLC 420 with resolution 30 mm (High range):	0.3 ... 18.0 m
- SLG 420:	0.3 ... 18.0 m
- SLG 420 (High range):	8.0 ... 50.0 m
Response time:	
- beam coding (normal):	1 - 48 beams = 10 ms 49 - 144 beams = 20 ms
- beam coding A:	1 - 48 beams = 15 ms 49 - 144 beams = 27 ms
Rated operating voltage:	24 VDC ±10% (PELV) supply unit to EN 60204 (power drop > 20 ms)
Rated operating current:	250 mA max. + 2 x 250 mA each OSSD
Wave length of the sensor:	870 nm
Safety outputs:	
Test cycle time:	750 ms
Test impulse length:	200 µs
Safety outputs:	2 x PNP-type semi-conductor, short-circuit proof
Switching voltage HIGH ²⁾ :	15 ... 26.4 V
Switching voltage LOW ²⁾ :	0 ... 2 V
Switching current:	0 ... 250 mA
Leakage current ³⁾ :	1 mA

Load capacity:	200 nF
Load capacity ⁴⁾ :	2 H
Admissible conduction resistance between OSSD and load:	2.5 Ω
Supply cable:	1 Ω
Contactor control (EDM):	
Input voltage HIGH (inactive):	17 ... 26.4 V
Input voltage LOW (active):	0 ... 2 V
Input current HIGH:	3 ... 10 mA
Input current LOW:	0 ... 2 mA
Input restart interlock	
Input voltage HIGH (active):	17 ... 26.4 V
Input voltage LOW (inactive):	0 ... 2 V
Input current HIGH:	3 ... 10 mA
Input current LOW:	0 ... 3 mA
Functions:	contactor control, beam blanking fixed and floating, setting mode
Operating modes:	Protective mode, start and restart interlock
Signal times:	
- Contactor control:	5 to 500 ms, adjustable
- Authorised operation restart interlock:	100 ms to 1500 ms, Signal acquisition with falling edge
- Start interlock:	250 to 500 ms, adjustable
LED indications:	
- transmitter:	Transmitting, status
- receiver:	OSSD ON, OSSD OFF, restart, signal reception, blanking, multifunction
Connection:	M12 connector plug with metal thread, receiver 8-pole, transmitter 4-pole
Ambient temperature:	-25° C ... +50° C at -25° C: Reduction of range by -10%
Storage temperature:	-25° C ... +70° C
Interface:	Diagnostics and function setting
Protection class:	IP67 (IEC 60529)
Resistance to vibration:	10 ... 55 Hz to IEC 60068-2-6
Resistance to shock:	10 g, 16 ms, to IEC 60028-2-29
Year of construction:	as of 2015 version 2.0

¹⁾ Resolution = beam distance + beam diameter 10 mm

²⁾ To EN 61131-2

³⁾ In case of failure, the leakage current flows to the OSSD cable. The downstream control element must recognise this state as LOW. A safety PLC must detect this state.

⁴⁾ The load induction generates an induced voltage during the switch-off, which compromises the downstream components (spark quenching element).

2.5.1 Technical data IP69K (additions)

For the IP69K versions, the same technical data is valid as described in point 2.5, with the exception of the following details:

Material of the enclosure:	Aluminium
- Protective tube:	PMMA plastic tubes
- End plugs:	PA 6
- Membrane:	V4A, Gore Tex membrane M12 x 1.5
Protection field heights:	
- SLC 420 IP69K with resolution 14 mm:	170 mm ... 1450 mm
- SLC 420 IP69K with resolution 30 mm:	170 mm ... 1450 mm
- SLG 420 IP69K:	500 mm, 800 mm, 900 mm
Range of the protection field:	
- SLC 420 IP69K with resolution 14 mm:	0.3 ... 7 m
- SLC 420 IP69K with resolution 30 mm:	0.3 ... 10 m
- SLG 420 IP69K:	0.3 ... 18 m
Connection:	screwed cable gland M16 x 1.5 cable connector M12 x 1; 4-pole fixed to transmitter, M12 x 1; 8-pole fixed to receiver integrated
Ambient temperature:	-10° C ... +50° C
Protection class:	IP69K

2.6 Response time (reaction time)

The response time depends on the height of the protection field, the resolution, the number of light beams and the beam coding.

SLC 420 Resolution 14 mm					
Protection field height [mm]	Beams [Number]	Response time [ms]	Response time with beam coding A [ms]	Weight Standard [kg]	Weight IP69K [kg]
170	16	10	15	0.9	1.6
250	24	10	15	1.2	1.9
330	32	10	15	1.5	2.3
410	40	10	15	1.8	2.6
490	48	10	15	2.0	3.0
570	56	20	27	2.3	3.3
650	64	20	27	2.5	3.7
730	72	20	27	2.8	4.1
810	80	20	27	3.1	4.5
890	88	20	27	3.4	4.8
970	96	20	27	3.6	5.2
1050	104	20	27	3.9	5.6
1130	112	20	27	4.2	6.0
1210	120	20	27	4.5	6.4
1290	128	20	27	4.7	6.8
1370	136	20	27	5.0	7.2
1450	144	20	27	5.2	7.6

SLC 420 Resolution 30 mm					
Protection field height [mm]	Beams [Number]	Response time [ms]	Response time with beam coding A [ms]	Weight Standard [kg]	Weight IP69K [kg]
170	8	10	15	0.9	1.6
250	12	10	15	1.2	1.9
330	16	10	15	1.5	2.3
410	20	10	15	1.8	2.6
490	24	10	15	2.0	3.0
570	28	10	15	2.3	3.3
650	32	10	15	2.5	3.7
730	36	10	15	2.8	4.1
810	40	10	15	3.1	4.5
890	44	10	15	3.4	4.8
970	48	10	15	3.6	5.2
1050	52	20	27	3.9	5.6
1130	56	20	27	4.2	6.0
1210	60	20	27	4.5	6.4
1290	64	20	27	4.7	6.8
1370	68	20	27	5.0	7.2
1450	72	20	27	5.2	7.6
1530	76	20	27	5.5	---
1610	80	20	27	5.8	---
1690	84	20	27	6.1	---
1770	88	20	27	6.3	---

SLC 420 Resolution 50 mm				
Protection field height [mm]	Beams [Number]	Response time [ms]	Response time with Beam coding A [ms]	Weight [kg]
170	4	10	15	0.9
250	6	10	15	1.2
330	8	10	15	1.5
410	10	10	15	1.8
490	12	10	15	2.0
570	14	10	15	2.3
650	16	10	15	2.5
730	18	10	15	2.8
810	20	10	15	3.1
890	22	10	15	3.4
970	24	10	15	3.6
1050	26	10	15	3.9
1130	28	10	15	4.2
1210	30	10	15	4.5
1290	32	10	15	4.7
1370	34	10	15	5.0
1450	36	10	15	5.2
1530	38	10	15	5.5
1610	40	10	15	5.8
1690	42	10	15	6.1
1770	44	10	15	6.3

SLG 420					
Beams [Number]	Beam distance [mm]	Response time [ms]	Response time with beam coding A [ms]	Weight Standard [kg]	Weight IP69K [kg]
2	500	10	15	2.5	3.7
3	400	10	15	3.5	5.1
4	300	10	15	3.6	5.2

2.7 Effective resolution

The effective resolution in case of activated blanking of floating beams can be found in the following table:

Blanked beams	Physical resolution	Effective resolution
1	14	24
2	14	34
3	14	44
4	14	54

Blanked beams	Physical resolution	Effective resolution
1	30	48
2	30	68
3	30	88
4	30	108

Blanked beams	Physical resolution	Effective resolution
1	50	88
2	50	128
3	50	168
4	50	208

2.8 Safety classification

Standards:	EN ISO 13849-1, EN 62061
PL:	up to e
Control category:	up to 4
PFH value:	$6.19 \times 10^{-9} / h$
SIL:	up to 3
Service life:	20 years

2.9 Functions

The system consists of a receiver and a transmitter. For the described functions, no further switching elements are required. For the diagnostics and function selection, a PC-software is offered as an accessory. For the diagnostics or the setting of parameters with a PC, the BUS converter NSR-0801 is required (not included in scope of delivery).

The system has the following features:

- Protective mode (automatic start after release of the protection field)
- Start interlock
- Restart Interlock (manual reset)
- Contactor control (EDM)
- Beam coding
- Blanking of fixed protection field areas
- Blanking of movable protection field areas

Factory setting

The system features many functions without needing any additional devices. The following table gives an overview of the possible functions and the factory settings configuration.

Function	Factory setting	Configuration
Protective mode	not active	External wiring
Restart interlock (manual reset)	not active	External wiring
Blanking fixed/floating	not active	With BUS converter NSR-0801 and PC-software
Contactor control (EDM)	not active	With BUS converter NSR-0801 and PC-software
Start interlock	not active	With BUS converter NSR-0801 and PC-software
Beam coding A	not active	With BUS converter NSR-0801 and PC-software

2.9.1 Protective mode

The protective mode switches the OSSD outputs to ON state (protection field not interrupted), without external release of a switching device. The protected operation is activated with an electrical connection between pin 1 and pin 6 of the receiver

This type of protection generates an automatic restart of the machine if the protection field is not interrupted.



This operating mode may only be chosen in conjunction with the restart interlock (manual reset) of the machine. This operating mode must not be chosen, when persons can step behind the protection field.



With a new start of the system a 24 VDC H signal on the input of pin 1 causes the operating mode to change to the setting mode.

2.9.2 Restart interlock (manual reset)

The restart interlock (manual reset) prevents an automatic enabling of the outputs (OSSD's ON state) after switch-on of the operating voltage or an interruption of the protection field. The system switches the outputs only to ON state, when an external command device (restart button) generates an enabling signal at the restart input (receiver). The operating mode restart interlock is activated with an electrical connection between pin 5 and pin 6 on the receiver.



The command devices (enabling button) must be installed outside of the hazardous area. The hazardous area must be easily visible to the user.



By default neither the restart interlock (manual reset) nor the protective mode is active. You must choose one of both operating modes to enable the OSSD outputs. If no type of protection is selected, you will obtain the following signalisation through the LED status indication in the receiver: **LED OSSD OFF (red) + LED restart (yellow) flashing**

2.9.3 Fixed blanking SLC 420

The SLC 420 can blank stationary parts in the protection field.

Multiple protection field areas can be blanked. If small changes are made within the fixed blanking area, each time 1 beam can be additionally blanked to increase the tolerance. Refer to the chapter Floating blanking

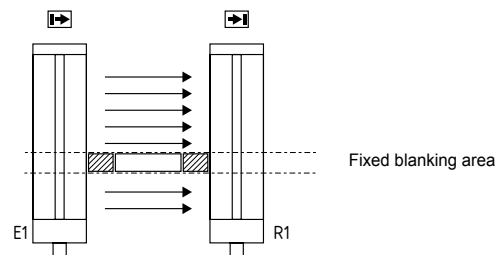

The range of the fixed blanking can be arbitrarily chosen in the protection field.

The first beam line, which realises the optical synchronisation and is located immediately behind the diagnostic window, cannot be blanked. The area of the fixed blanking must not be modified after the teach-in process. Any change of the area or removal of the part from the protection field will be detected by the system. As a result, the outputs are disabled (locked). This locking can be neutralised by executing a new teach-in process in accordance with the actual beam interruptions.



The function is activated by means of the NSR-0801 BUS converter and a PC or laptop. If the function is activated, the LED blanking in the diagnostic window of the receiver starts flashing.



- The remaining lateral areas must be protected against intrusion by means of mechanical covers.
- The lateral covers must be fixed with the object.
- Partial covers are not authorised.
- After the fixed blanking, the protection field must be tested by means of the test rod.
- The restart interlock function of the safety light curtain or the machine must be activated.

2.9.4 Floating blanking SLC 420

The SLC 420 can blank movable parts in the protection field.

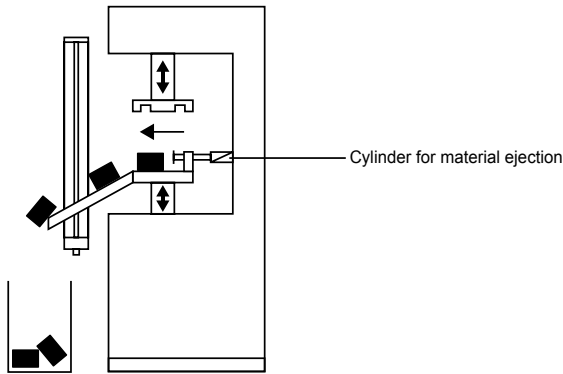

The function enables an arbitrary floating blanking of partial areas in the protection field. The first beam, which is located immediately behind the diagnostic window, cannot be blanked.

The SLC 420 can blank one or more beams in the protection field. A combination of fixed and floating blanking is possible.

This function allows for an interruption of the protection height without the outputs being disabled in case of material movement in the protection field, e.g. material ejection or process-controlled material movement. In this way, the physical resolution changes into an effective resolution. This effective resolution must be used to calculate the safety distance. Use formula (1) to calculate the safety distance with the effective resolution if a maximum of 2 light beams are blanked; use formula (3) indicated in the "Safety distance" chapter if more than 2 light beams are blanked. The number of beams to be blanked is limited by the software, see Table Effective resolution.

In a system with a physical resolution of 14 mm, the effective resolution changes to a value of 34 mm with floating blanking of two beams. The effective resolution must be permanently known and well visible on the information label of the receiver.



The muting is configured using the BUS converter NSR-0801 and a PC / Laptop. If the function is activated, the LED blanking in the diagnostic window of the receiver starts flashing.



Perform a new calculation of the safety distance with the effective resolution. Adjust the safety distance in accordance with your calculation.



The Standard IEC/TS 62046 describes the measures that may be necessary to protect persons from hazards due to protected areas that are blanked.

2.9.5 Floating blanking SLG 420

The SLG 420 can blank movable objects in the protection field.

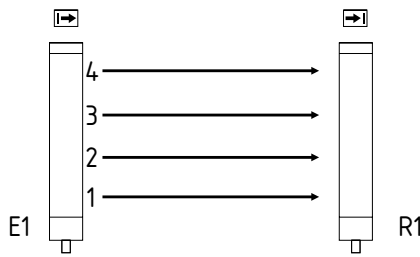

The function of floating blanking is allowed for only one beam taking into consideration the protective function. This function can be used for temporary beam suppression due to environmental conditions.

The first beam line, which realises the optical synchronisation and is located immediately behind the diagnostic window, cannot be blanked.



The function is activated by means of the NSR-0801 BUS converter and a PC or laptop. If the function is activated, the LED blanking in the diagnostic window of the receiver starts flashing.



- The blanking of beams is not available for an SLG 420 with 2 beams!
- The blanking of one beam at the most in the SLG 420 3-beam version or the SLG 420 4-beam version is available, provided that the protective function is taken into account.
- The restart interlock (manual reset) function of the safety light grid or the machine must be activated.
- The standard IEC/TS 62046 includes information, which describes possibly required additional measures to prevent a person from reaching a hazard through the blanking areas of a protection field.
- After configuration, the protection field must be checked by a responsible person by means of a test rod; in addition to that, this person must compare the size of the blanked area to the object size and if necessary provide for additional covers or a larger distance of the safety guard with regard to the hazardous point.

2.9.6 Contactor control (EDM)

The contactor control monitors the controlled switching elements (auxiliary contacts of the contactors) of both outputs. This monitoring is realised after each interruption of the protection field and prior to the restart (enabling) of the outputs. In this way, malfunctions of the relays are detected, e.g. contact welding or contact spring breakage. If the light curtain detects a malfunctioning of the switching elements, the outputs are locked, i.e. after elimination of the failure, a Power Reset is required. **The auxiliary contacts must only be connected, when the function is activated!**

After the solving of a fault, a system start must be performed (voltage reset)



The contactor control is not activated upon delivery. This function is activated by means of the NSR-0801 BUS converter and a PC or laptop.

Activation of the contactor control (EDM) without software

The contactor control can be activated without PC software as of firmware version 1.23, by means of cable bridges (refer to chapter Parameterisation of the Contactor Control without PC software).

2.9.7 Start interlock

The start interlock prevents an automatic start of the machine when the supply voltage is switched on. After enabling the start interlock - by the one-time interruption of the protection field -, this protective function is deactivated until the next power reset.



The start interlock is not activated upon delivery. This function is activated by means of the NSR-0801 BUS converter and a PC or laptop.

2.10 Self-test

The system performs a complete self-test within 2 seconds after the operating voltage has been switched on. If the protection field is not interrupted, the system switches to the ON condition. In case of an error, the outputs at the receiver do not switch to the ON state. The LED OSSD OFF starts flashing, thus emitting an error message. For more information, refer to chapter Fault diagnosis.

During operation, the system continuously executes a self-test. Safety-relevant faults are detected within the cycle time and cause the outputs to be switched off.

2.11 Beam coding A

The beam coding of the safety light curtain must be adjusted, when systems operating in each other's vicinity and a set-up as shown in the image below (no interference) is impossible. With beam coding A, a receiver can distinguish the beams of the transmitter with the same beam coding A, which are destined to this particular receiver, from foreign beams. The beam coding A must be set for each sensor (receiver and transmitter) individually. The function is activated by means of the NSR-0801 BUS converter and a PC or laptop.

If adjacent systems are operated without beam coding A, the user is at risk.

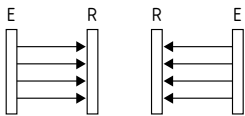

No interference

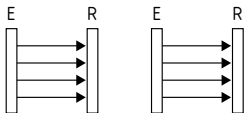

Interference:

beam coding A required!

- The beam coding A avoids mutual interference of adjacent systems.
- The beam coding A is permanently shown by the transmitter and the receiver by means of flashing LED's (refer to LED status information).



The response time of the system is increased when beam coding A is used. To this end, the safety distance must be adjusted to the hazardous movement. Refer to chapter Response time.

3. Mounting

3.1 General conditions

The following guidelines are provided as a preventative warning notice to ensure safe and appropriate handling. These guidelines are an essential part of the safety instructions and therefore must always be observed and respected.



- The SLC must not be used on machines, which can be stopped electrically in case of emergency.
- The safety distance between the SLC and a hazardous machine movement must always be observed and respected.
- Additional mechanical safety guards must be installed so that the operator has to pass by the protection field to reach the hazardous machine parts.
- The SLC must be installed so that the personnel always must be within the detection zone when operating the machine. An incorrect installation can lead to serious injuries.
- Never connect the outputs to +24VDC. If the outputs are wired to +24VDC, they are in ON state, as a result of which they are unable to stop a hazardous situation occurring on the application/machine.
- The safety inspections must be conducted regularly.
- The SLC must not be exposed to inflammable or explosive gasses.
- The connecting cables must be connected in accordance with the installation instructions.
- The fixing screws of the end caps and the mounting angle must be firmly tightened.

3.2 Protection field and approach

The protection field of the SLC consists of the entire range located between the protection field markings of transmitter and receiver. Additional protective devices must ensure that the operator has to pass by the protection field to reach the hazardous machine parts.

The SLC must be installed so that personnel are always located within the detection zone of the safety device when operating the hazardous machine parts to be secure.

Correct installation

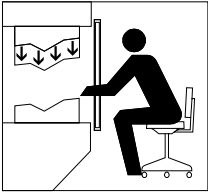

Hazardous machine parts can only be reached after passing through the protection field.

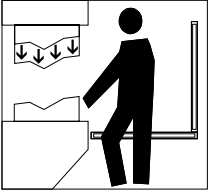

Persons between the protection field and hazardous machine parts must be prevented (protection against stepping over).

Unauthorised installation

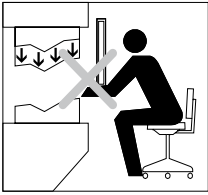

Hazardous machine parts can be reached without passing through the protection field.

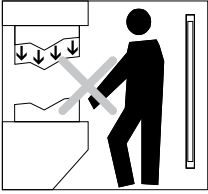

Persons between the protection field and hazardous machine parts is enabled.

3.3 Alignment

Procedure in automatic operating mode:

1. The transmitter and the receiver must be fitted parallel to each other and at the same height.
2. Turn the transmitter and monitor the diagnostic window of the receiver. Fix the light curtain, when the LED OSSD ON (green) is on and the LED signal reception (orange) is off.
3. Determine the max. rotating angle to the left and to the right, at which the LED OSSD ON (green) is on and tighten the mounting screws in central position. Make sure that the LED signal reception (orange) is not on or flashing.

3.4 Setting mode

The alignment of the sensors is carried out using the setting mode.

Activating setting mode

If +24 V is on the input (pin 1, receiver) "Release restart interlock" at system start for at least two seconds (by pressing the button restart), the system changes over to the setting mode of operation.

The signal strength at the receiver is indicated with the signal strength LED (colour orange) through light pulses. The better the alignment, the higher the frequency of the light pulses. The alignment is optimal when the light pulses switch over to continuous light.

If there is no optical synchronisation between the transmitter and the receiver, a light pulse is emitted every 3 seconds. The setting mode is ended by a system start (+UB OFF/ON).

Additional signalling with the SLG 420 by the status light

In this mode the signal strength of the beam is signalled to the status indicator with the lowest value through light pulses (colour yellow). The better the alignment, the higher the frequency of the light pulses. The alignment is correct when the light pulses switch over to continuous light.

3.5 Safety distance

The safety distance is the minimum distance between the protection field of the safety light curtain and the hazardous area. The safety distance must be observed to ensure that the hazardous area cannot be reached before the hazardous movement has come to standstill.

Calculation of the safety distance to EN ISO 13855

The safety distance depends on the following elements:

- Stopping time of the machine (calculation by run-on time measurement)
- Response time of the machine and the safety light curtain and the downstream relay (entire safety guard)
- Approach speed
- Resolution of the safety light curtain
- Vertical or horizontal installation

Safety light curtain SLC 420

The safety distance for resolutions 14 mm up to 40 mm (vertical installation) is calculated by means of the following formula:

$$(1) S = K \times T + C \text{ [mm]}$$

S = Safety distance [mm]

K = Approach speed 2000 mm/s

T = Total reaction time (machine run-on time, reaction time of the safety guard, relays, etc.)

d = Resolution of the safety light curtain

C = additional distance depending on the resolution,

$$C = 8 (d - 14) \text{ [mm]}$$

If value $S \leq 500$ mm after the calculation of the safety distance, then use this value.

If the value $S \geq 500$ mm then redetermine the distance S using an approach speed K of 1600 mm/s:

$$(2) S = 1600 \text{ mm/s} \times T + 8 (d - 14) \text{ [mm]}$$

If the new value $S > 500$ mm, use this value as safety distance.

If the new value $S < 500$ mm, use a minimum distance of **S = 500 mm**.

Example:

Reaction time of the safety light curtain = 10 ms

Resolution of the safety light curtain = 14 mm

Stopping time of the machine = 330 ms

$$S = 2000 \text{ mm/s} \times (330 \text{ ms} + 10 \text{ ms}) + 8(14 \text{ mm} - 14 \text{ mm})$$

$$S = 680 \text{ mm}$$

S > 500 mm, therefore new calculation with K = 1600 mm/s

$$S = 544 \text{ mm}$$

Calculation of the safety distance for SLG 420 and SLC 420 with a resolution d > 40 mm

$$(3) S = (1600 \text{ mm/s} \times T) + 850 \text{ mm}$$

S = Safety distance [mm]

T = Stopping time of the machine + reaction time of the safety light curtain

K = Approach speed 1600 mm/s

C = Additional distance 850 mm

The following mounting heights must be observed:

Number of beams	Mounting height above reference level in mm
2	400, 900
3	300, 700, 1100
4	300, 600, 900.12

Safety distance to the hazardous area

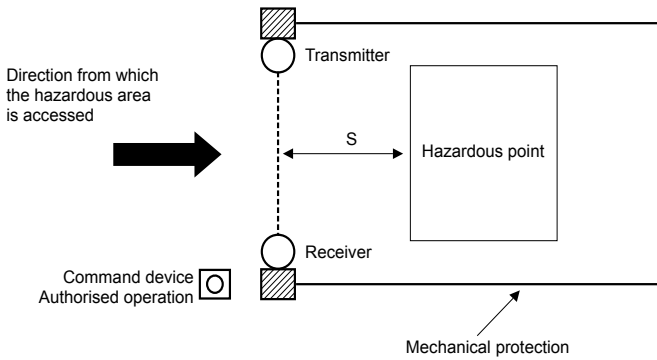

The safety distance between the safety light curtain and the hazardous point must always be respected and observed. If a person reaches the hazardous point before the hazardous movement has come to a standstill, he or she is exposed to serious injuries.

Safety distance to the hazardous area

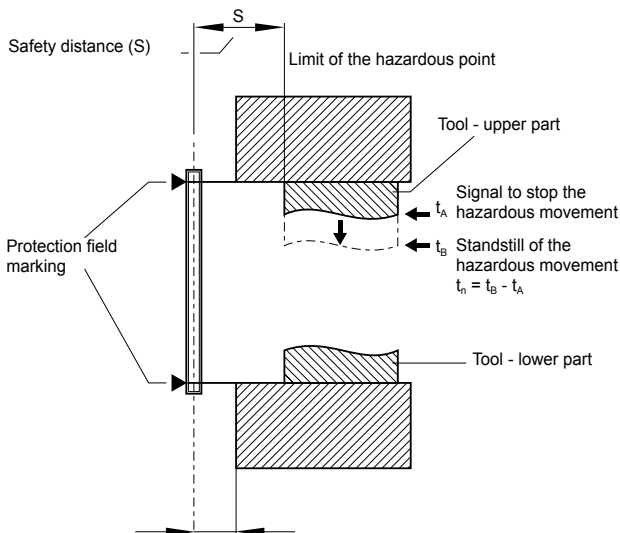

≤ 75 mm = max. distance for protection against stepping over
To prevent persons from stepping over the protection field this dimension must be imperatively respected and observed.

The formulae and calculation examples are related to the vertical set-up (refer to drawing) of the light curtain with regard to the hazardous point. Please observe the applicable harmonised EN standards and possible applicable national regulations.



To calculate the minimum distances of the safety guards with regards to the hazardous point, the EN ISO 13855 must be observed. If reaching through the protection field is possible, take care with the calculation of the safety distance and add an amount as per norm EN ISO 13855.

The norm EN ISO 13855 defines two types of safety distances,
- Access **through** the protection area with an additional distance C, according to the resolving power
- Access **over** the protection area with an additional distance C_{RO} according to table 1

If it is possible to reach through the hazardous area (vertical alignment) then both values C and C_{RO} have to be determined. The larger of the two values is to be used for calculating the safety distance. Calculating the safety distance with C_{RO}:

$$S_{CRO} = K \times T + C_{RO}$$

K = Approach speed

T = Total reaction time (machine run-on time, reaction time of the safety guard, relays, etc.)

C_{RO} = additional distance due to reaching through the hazardous area with parts of body, see Table 1 for value

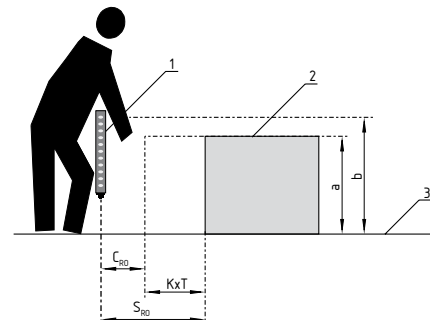

1 Safety sensor

2 Hazardous point

3 Floor

a Height of the hazardous point

b Height of the topmost beam of the safety sensor

Reaching through the protective area of a non-contact functioning guard system (extract EN ISO 13855)

Height of the hazardous point a [mm]	Height b of the upper edge of the protection area of the non-contact functioning guard system											
	900	1000	1100	1200	1300	1400	1600	1800	2000	2200	2400	2600
Additional distance C_{RO} to the hazardous area [mm]												
2600	0	0	0	0	0	0	0	0	0	0	0	0
2500	400	400	350	300	300	300	300	300	250	150	100	0
2400	550	550	550	500	450	450	400	400	300	250	100	0
2200	800	750	750	700	650	650	600	550	400	250	0	0
2000	950	950	850	850	800	750	700	550	400	0	0	0
1800	1100	1100	950	950	850	800	750	550	0	0	0	0
1600	1150	1150	1100	1000	900	850	750	450	0	0	0	0
1400	1200	1200	1100	1000	900	850	650	0	0	0	0	0
1200	1200	1200	1100	1000	850	800	0	0	0	0	0	0
1000	1200	1150	1050	950	750	700	0	0	0	0	0	0
800	1150	1050	950	800	500	450	0	0	0	0	0	0
600	1050	950	750	550	0	0	0	0	0	0	0	0
400	900	700	0	0	0	0	0	0	0	0	0	0
200	600	0	0	0	0	0	0	0	0	0	0	0
0	0	0	0	0	0	0	0	0	0	0	0	0

Schedule 1

a = Height of the hazard spot [mm]

b = Height of the upper edge of the protection area of the AOPD

C_{RO} = Additional distance to the hazardous area [mm]

Determination of the additional distance C_{RO} from the table:

- 1) Locate the height of the upper edge of the hazardous area **a** (left table column)
- 2) Locate the height of the protection area **b** (upper table row)
- 3) C_{RO} is to be taken from the crossing point of both axes

If the known value for **a** and **b** is between the table values, the next higher value is to be used.

Example: Calculation of the safety distance, vertical installation

Total response time $T = 220$ ms, resolving capability $d = 30$ mm, height of the hazardous area 1400 mm, height of the protection area above the floor 1600 mm

$$S = K \cdot T + C = 2000 \text{ mm/s} \cdot 220 \text{ ms} + 8 (30 - 14) = 568 \text{ mm}$$

($S > 500$ mm, following $K = 1600$ mm/s)

$$S = K \cdot T + C = 1600 \text{ mm/s} \cdot 220 \text{ ms} + 8 (30 - 14) = 480 \text{ mm}$$

($S < 500$ mm, following $S = 500$ mm) **$S = 500$ mm**

Safety distance C_{RO}

$$S_{CRO} = K \cdot T + C_{RO} = 1600 \text{ mm/s} \cdot 220 \text{ ms} + 650 \text{ mm} = 1002 \text{ mm}$$

$S_{CRO} > S$ i.e.

Safety distance **$S = 1002$ mm**

If the safety distance of 1002 mm is too large for the application, the protection field height can be increased from 1600 mm to 1800 mm, this makes the value $C_{RO} = 0$ mm (table 1).

Result: By adjusting the protection field height to the value 1800 mm above the floor results in a safety distance: **$S = 500$ mm**

3.5.1 Minimum distance to reflecting surfaces

During the installation, the effects of reflecting surfaces must be taken into account. In case of an incorrect installation, interruptions of the protection field could possibly not be detected, which could lead to serious injuries. The hereafter-specified minimum distances with regard to reflecting surfaces (metal walls, floors, ceilings or parts) must be imperatively observed.

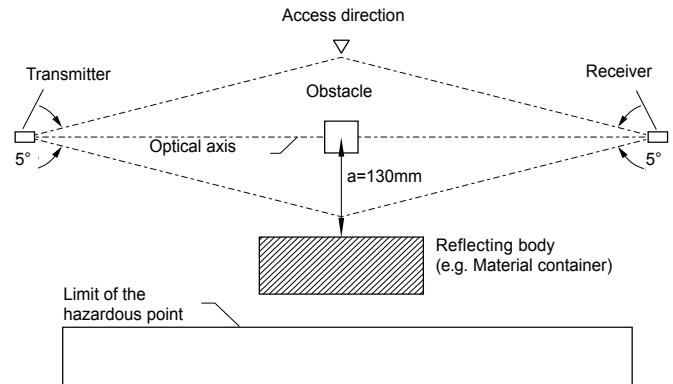

Safety distance a

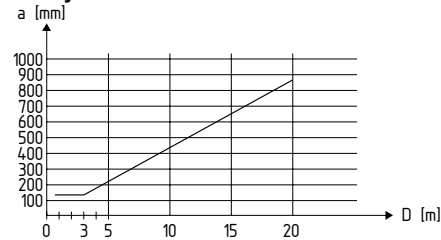

Calculate the minimum distance to reflecting surfaces as a function of the distance with an aperture angles of $\pm 2.5^\circ$ degrees or use the value from the table below:

Distance between transmitter and receiver [m]	Minimum distance a [mm]
0.2 ... 3.0	130
4	175
5	220
7	310
10	440
15	660

Formula: $a = \tan 2.5^\circ \times L$ [mm]

a = Minimum distance to reflecting surfaces
 L = Distance between transmitter and receiver

3.6 Dimensions

3.6.1 Dimensions transmitter and receiver SLC 420 (Standard)

All measurements in mm.

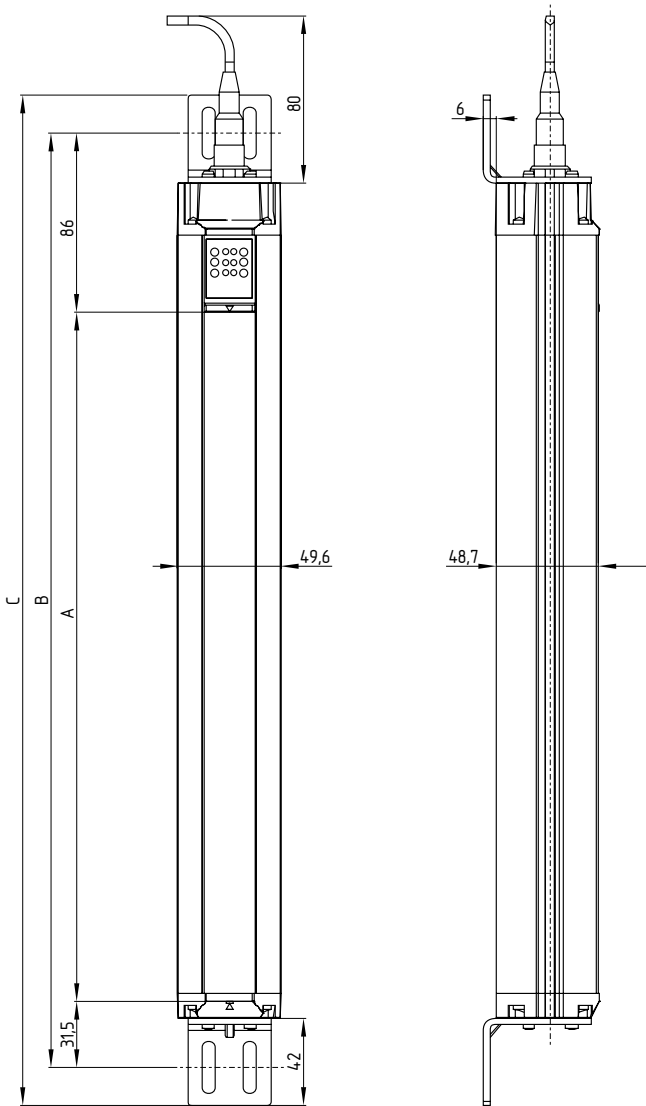

3.6.2 Dimensions transmitter and receiver SLG 420 (Standard)

All measurements in mm.

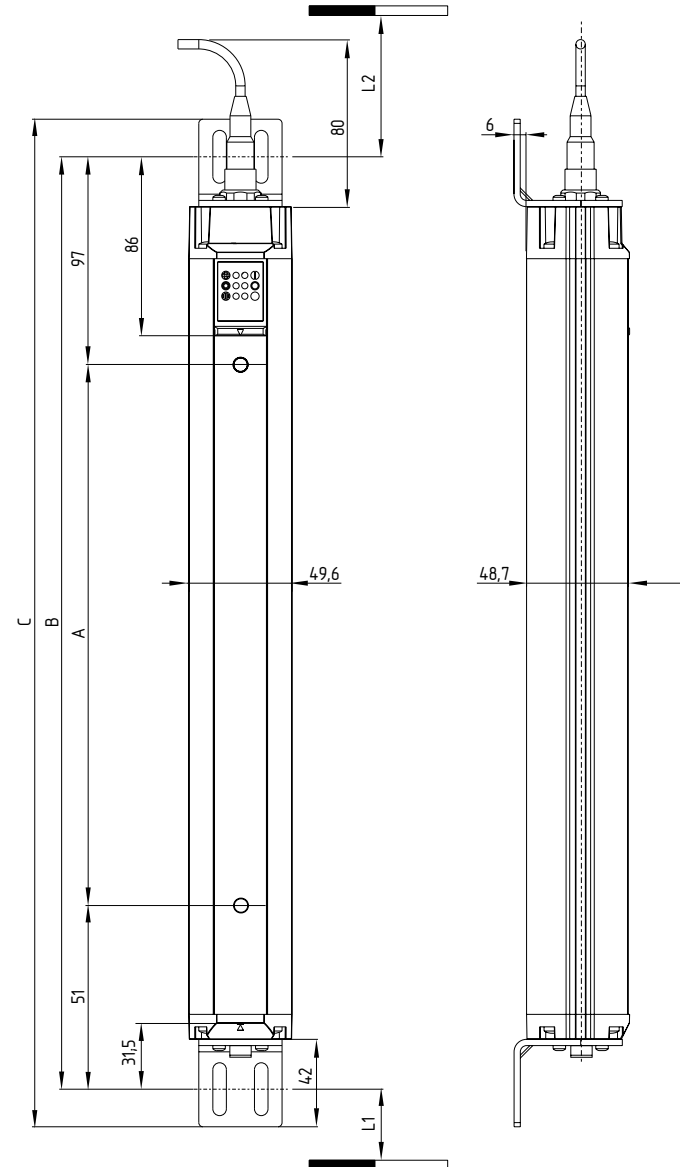

Type	A Protected height	B Mounting dimension	C Total length
SLC420-E/R0170-XX-RFB	170	288	324
SLC420-E/R0250-XX-RFB	250	368	404
SLC420-E/R0330-XX-RFB	330	448	484
SLC420-E/R0410-XX-RFB	410	528	564
SLC420-E/R0490-XX-RFB	490	608	644
SLC420-E/R0570-XX-RFB	570	688	724
SLC420-E/R0650-XX-RFB	650	768	804
SLC420-E/R0730-XX-RFB	730	848	884
SLC420-E/R0810-XX-RFB	810	928	964
SLC420-E/R0890-XX-RFB	890	1008	1044
SLC420-E/R0970-XX-RFB	970	1088	1124
SLC420-E/R1050-XX-RFB	1050	1168	1204
SLC420-E/R1130-XX-RFB	1130	1248	1284
SLC420-E/R1210-XX-RFB	1210	1328	1364
SLC420-E/R1290-XX-RFB	1290	1408	1444
SLC420-E/R1370-XX-RFB	1370	1488	1524
SLC420-E/R1450-XX-RFB	1450	1568	1604
SLC420-E/R1530-XX-RFB	1530	1648	1684
SLC420-E/R1610-XX-RFB	1610	1728	1764
SLC420-E/R1690-XX-RFB	1690	1808	1844
SLC420-E/R1770-XX-RFB	1770	1888	1924

Type	A Beam distance	B Mounting dimension	C Total length	L1	L2
SLG420-E/R0500-02-RF	500	648	684	349	303
SLG420-E/R0800-03-RF	400	948	984	249	203
SLG420-E/R0900-04-RF	300	1088	1124	209	203

L1 = Mounting distance (mm) between floor and slotted hole centre (short end cap)

L2 = Mounting distance (mm) between floor and slotted hole centre (diagnostic window)

3.6.3 Dimensions transmitter and receiver SLC 420 IP69K
All measurements in mm.

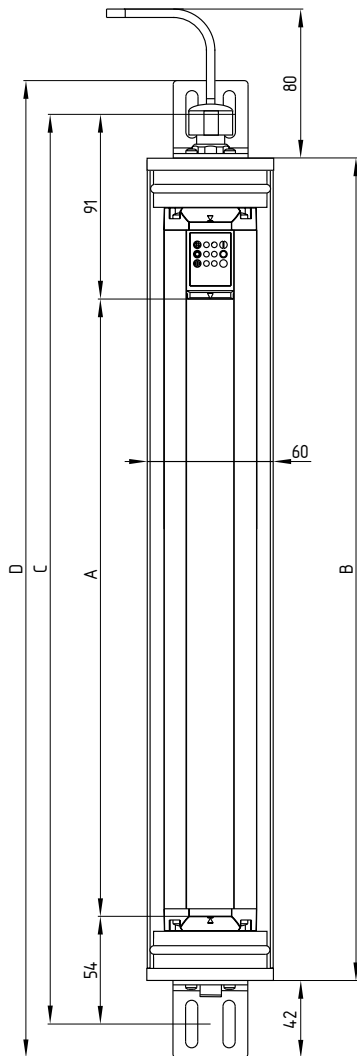

Type	A Protected height	B Sensor length	C Moun- ting dimen- sion	D Total length
SLC420-E/R0170-xx-69-RFB	170	267	315	351
SLC420-E/R0250-xx-69-RFB	250	347	395	431
SLC420-E/R0330-xx-69-RFB	330	427	475	511
SLC420-E/R0410-xx-69-RFB	410	507	555	591
SLC420-E/R0490-xx-69-RFB	490	587	635	671
SLC420-E/R0570-xx-69-RFB	570	667	715	751
SLC420-E/R0650-xx-69-RFB	650	747	795	831
SLC420-E/R0730-xx-69-RFB	730	827	875	911
SLC420-E/R0810-xx-69-RFB	810	907	955	991
SLC420-E/R0890-xx-69-RFB	890	987	1035	1071
SLC420-E/R0970-xx-69-RFB	970	1067	1115	1151
SLC420-E/R1050-xx-69-RFB	1050	1147	1195	1231
SLC420-E/R1130-xx-69-RFB	1130	1227	1275	1311
SLC420-E/R1210-xx-69-RFB	1210	1307	1355	1391
SLC420-E/R1290-xx-69-RFB	1290	1387	1435	1471
SLC420-E/R1370-xx-69-RFB	1370	1467	1515	1551
SLC420-E/R1450-xx-69-RFB	1450	1547	1595	1631

3.6.4 Dimensions transmitter and receiver SLG 420 IP69K
All measurements in mm.

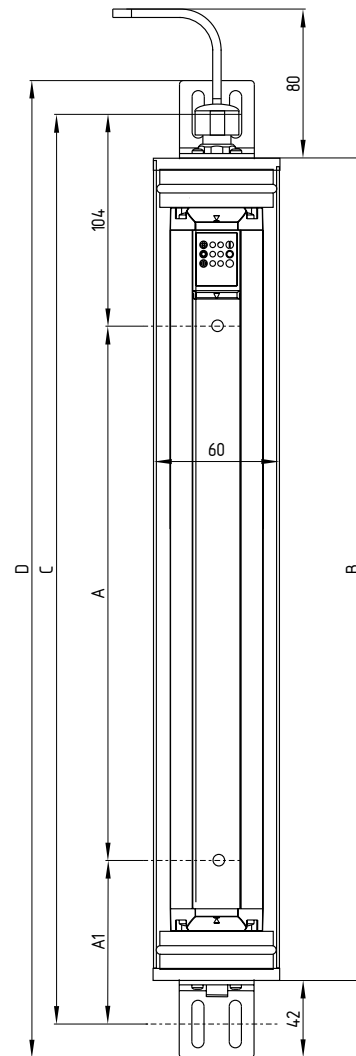

Type	A Beam dis- tance	A1 Beam posi- tion	B Sen- sor length	C Moun- ting dimen- sion	D Total length
SLG420-E/R0500-02-69-RF	500	71	627	675	711
SLG420-E/R0800-03-69-RF	400	71	927	975	1011
SLG420-E/R0900-04-69-RF	300	111	1067	1115	1151

3.7 Scope of delivery and accessories

3.7.1 Included in delivery

Test rod PLS

The test rod, according to the resolution is used for testing the protection field.

Mounting kit MS-1030 (SLC/SLG 420 Standard)

The mounting kit consists of 4 steel angles and 16 fixing screws.

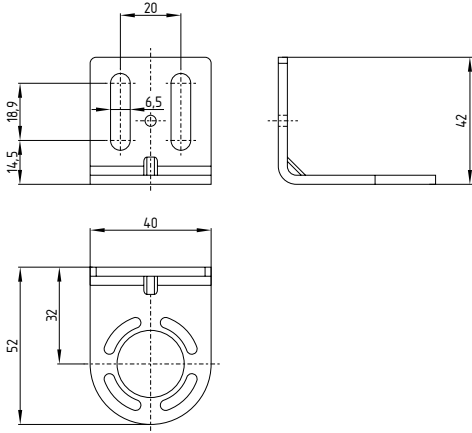

Mounting kit MS-1038 (SLC/SLG 420 IP69K)

The mounting kit consists of 4 pcs V4A stainless steel brackets and 16 pcs V4A fastening screws

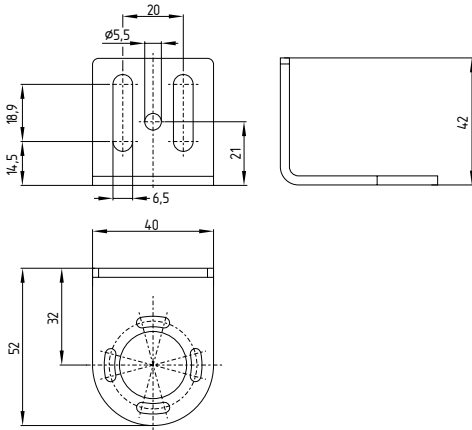

Integrated status indication (only SLG 420)

The status indication at the receiver indicates the switching condition of the outputs OSSD1 and OSSD2.

- Green = Outputs in ON state (H-signal 24V)
- Red = Outputs in OFF state (L-signal 0V)
- Yellow = Restart Interlock released / Setting mode

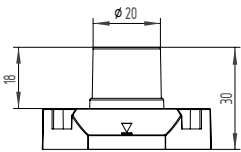

3.7.2 Optional accessories

Centre fixing MS-1051

Mounting kit consists of 2 steel angles, 4 screws and 4 T-slot nuts for central fixing

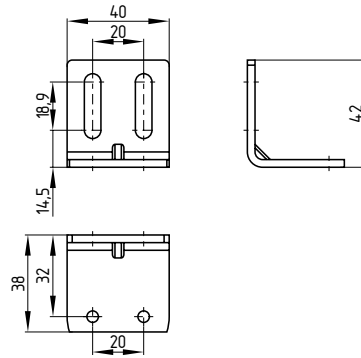

Connecting cable for transmitter

Item Number	Designation	Description	Length
1207741	KA-0804	Female connector M12, 4-pole	5 m
1207742	KA-0805	Female connector M12, 4-pole	10 m
1207743	KA-0808	Female connector M12, 4-pole	20 m

Connecting cable for Receiver

Item Number	Designation	Description	Length
1207728	KA-0904	Female connector M12, 8-pole	5 m
1207729	KA-0905	Female connector M12, 8-pole	10 m
1207730	KA-0908	Female connector M12, 8-pole	20 m

BUS converter NSR-0801

Converter for parameterisation and diagnostics. Detailed information can be found in the operating instructions manual of the NSR-0801.

Included in delivery: integrated connecting cable, PC-software USB 2.0 connection (L x W x H, 122 x 60 x 35 mm), dimensions exclude cable.

MSD4 Vibration damper

Kit consisting of: 8 vibration dampers 15 x 20 mm, 8 cylinder head screws M5 with hexagon socket, 8 spring washers

The MSD4 vibration damper kit is recommend to be used for damping vibrations and oscillations (such as presses and stamps) on the SLC/SLG. In this way, the availability of the SLC/SLG is increased.

4. Electrical connection

4.1 Wiring example default

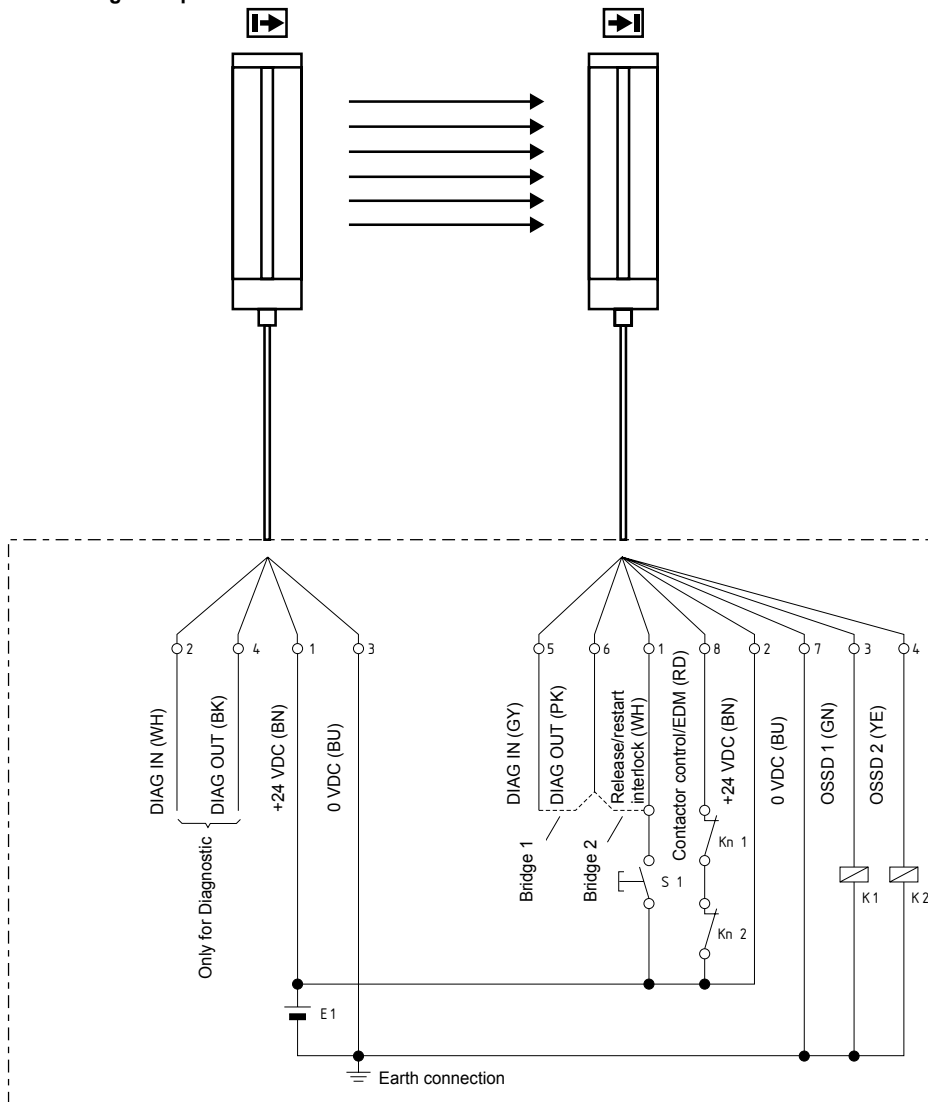

Restart interlock (manual reset) (bridge 1)

By bridging DIAG IN (pin 5) and DIAG OUT (pin 6), the restart interlock (manual reset) is activated.

Protective mode (bridge 2)

By bridging DIAG OUT (pin 6) and enable (pin 1), the automatic protective mode is activated. Do not connect S1.

- K1, K2: Relay for processing the switching outputs OSSD 1, OSSD 2
- Kn1, Kn2: Auxiliary contacts of the last switching relay (optional) signals at input EDM (pin 8): only to be connected when the function is activated
- S1: Command device for restart (optional)
- E1: Power supply 24 VDC +/-10%



For proper functioning, the operating mode restart interlock or operating mode automatic is to be wired.



Upon delivery, the "contactor control" function is deactivated. The function is activated by means of the NSR0801 BUS converter and the PC software.

4.2 Activation of the contactor control (EDM) without PC software

The contactor control can be activated without PC software as of firmware version 2.0 in diagnostic mode by means of cable bridges.

To activate the EDM function without PC software, proceed in the following way:

Establish the connections in accordance with the wiring diagram, see below.



Both outputs OSSD1 and OSSD2 of the light curtain must be separated from the machine control.

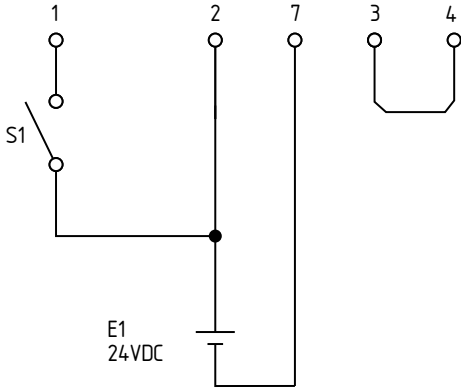

The parameter configuration EDM is activated for at least 2 seconds when the system starts if there is a wire link between OSSD 1 → OSSD2 and a +24V level on the input, restart interlock.

The active operating mode parameterisation is signalled by the cyclical changing of the red, yellow and green LEDs until the restart interlock button is no longer being pressed.

The parameterisation can now be made by pressing the button.

- If the red and green LEDs flash at the same time, this indicates that the EDM function is active, if only the red LED flashes then the EDM function is not active.
- Holding down the button from 2.5 to 6 seconds changes the state of the EDM function between active and not active and saves the current selection.

After the parameterisation, the link OSSD1 → OSSD2 is to be removed and a system start is to be carried out (+ 24V, OFF/ON). If the EDM function is parameterised with the wire link, the max. value of 500 ms is set for the signal delay. This value can be adjusted using the PC software / NSR-0801.

If the parameterisation is missing the process can be repeated.

4.3 Connector configuration Receiver, Transmitter & Cable

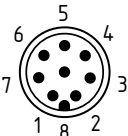
RECEIVER		Signal	
SLC: Connector male	Designation	Description	
M12 / 8 pol.			
	1 WH	Restart	Input
	2 BN	24 VDC	Power supply
	3 GN	OSSD 1	Safety output 1
	4 YE	OSSD 2	Safety output 2
	5 GY	Diagnostic IN	Input diagnostic data
	6 PK	Diagnostic OUT	Output Diagnostic data
	7 BU	0 VDC	Power supply
	8 RD	Contactor control EDM	Input

Cable: Connector female

M12 / 8 pole

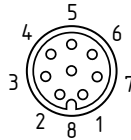

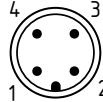
TRANSMITTER		Signal	
SLC: Connector male	Designation	Description	
M12 / 4 pol.			
	1 BN	24 VDC	Power supply
	2 WH	Diagnostic IN	Input diagnostic data
	3 BU	0 VDC	Power supply
	4 BK	Diagnostic OUT	Output Diagnostic data

Cable: Connector female

M12 / 4 pole

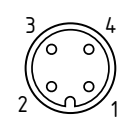

The colour codes are only valid for the cable types mentioned below "optional accessories".

5. Set-up and maintenance

5.1 Check before start-up

Prior to start-up, the following items must be checked by the responsible person.

Wiring check prior to start-up

1. If a power supply is used then it must comply with IEC 60449 PELV and should be able to bridge a loss of power for at least 20 ms as per EN 60204.
2. Presence of a voltage supply with correct polarity at the SLC.
3. The connecting cable of the transmitter is correctly connected to the transmitter and the connecting cable of the receiver correctly to the receiver.
4. The double insulation between the light curtain output and an external potential is guaranteed.
5. The outputs OSSD1 and OSSD2 are not connected to +24 VDC.
6. The connected switching elements are not connected to the +24 VDC and do not exceed the allowable load on the safety output. There are no short circuits between the safety switching outputs.
7. If two or more SLC are used within close range compared to each other, an alternating arrangement must be observed. Any mutual interference of the systems must be prevented.

Switch the SLC on and check the operation in the following way:

The component performs a system test during approx. 2 seconds after the operating voltage has been switched on. After that, the outputs are enabled if the protection field is not interrupted. The LED "OSSD ON" at the receiver is on.



In case of incorrect functionality, please follow the instructions listed in the chapter Fault diagnostic.

5.2 Maintenance



Do not use the SLC before the next inspection is terminated. An incorrect inspection can lead to serious and mortal injuries.

Conditions

For safety reasons, all inspection results must be archived. The operating principle of the SLC and the machine must be known in order to be able to conduct an inspection. If the fitter, the planning technician and the operator are different persons, please make sure that the user has the necessary information at his disposal to be able to conduct the maintenance.

5.3 Regular check

A regular visual inspection and functional test, including the following steps, is recommended:

1. The component does not have any visible damages.
2. The optics cover is not scratched or soiled.
3. Hazardous machinery parts can only be accessed by passing through the protection field of the SLC.
4. The staff remains within the detection area, when works are conducted on hazardous machinery parts.
5. The safety distance of the application exceeds the mathematically calculated one.

Operate the machine and check whether the hazardous movement stops under the hereafter-mentioned circumstances.

6. Hazardous machine parts do not move when the protection field is interrupted.
7. The hazardous machine movement is immediately stopped, when the protection field is interrupted with the test rod immediately before the transmitter, immediately before the receiver and in the middle between the transmitter and the receiver.
8. No hazardous machine movement when the test rod is within the protection field.
9. The hazardous machine movement comes to standstill, when the voltage supply of the SLC is switched off.

5.4 Half-yearly inspection

The following items must be checked every six months or when a machine setting is changed.

1. Machine stops or does not inhibit any safety function.
2. No machine modification or connection change, which affects the safety system, has taken place.
3. The outputs of the SLC are correctly connected to the machine.
4. The total response time of the machine does not exceed the response time calculated during the first putting into operation.
5. The cables, the connectors, the caps and the mounting angles are in perfect condition.

5.5 Cleaning

If the optics cover of the sensors is extremely soiled, the OSSD outputs can be disabled. Clean with a clean, soft cloth with low pressure.

The use of aggressive, abrasive or scratching cleaning agents, which could attack the surface, is prohibited.

6. Diagnostic

6.1 LED status information

Receiver	Function	LED colour	Description
	Multifunction	yellow-green	Function display, Beam coding
	Blanking	blue	Protection field(s) inactive (blanking)
	Signal reception	orange	Evaluation of the signal reception, signal quality set-up mode
	Restart	yellow	Input for command device, AOPD is waiting for enable signal
	OSSD OFF	red	Safety switching output in OFF state
	OSSD ON	green	Safety switching output in ON state

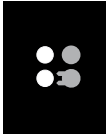
Transmitter	Function	LED colour	Description
	Transmitting	orange	Transmitter active
	Status	green	Function display, Beam coding

Receiver LED	Status LED	Description
OSSD ON	ON	Protection field clear
	flashing	Diagnostic mode active
OSSD OFF	ON	Safety switching output in OFF state
	flashing	Diagnostic mode active, error output refer to Fault diagnostic table
Restart	ON	Start or restart interlock (manual reset) active, signal expected at input restart interlock
Signal reception	ON/flashing	Signal reception too low, check alignment and installation height between transmitter and receiver
		Cleaning the black profile cover, set-up mode - signal state indicator
Blanking	1 flash	Fixed blanking of the protection field(s)
	2 flash	Floating blanking, max. 1 beam
	3 flash	Floating blanking, more beams
	4 flash	Floating (max. 1 beam) and fixed blanking of protection field(s)
	5 flash	Floating (multiple beams) and fixed blanking of protection field(s)
Multifunction	flashing	Beam coding A is active

Transmitter LED	Status LED	Description
Transmitting	ON	Standard operation, transmitter active
	flashing	Configuration error
Status	flashing	Beam coding A is active

6.2 Fault diagnostic

After the operating voltage for the light barrier has been switched on, the safety-monitoring module performs an internal self-test. When a fault is detected, a corresponding flashing pattern is emitted at the receiver through the LED OSSD OFF (red). Each fault display is followed by a one-second delay.

LED OSSD OFF	Fault feature	Action
Red and yellow LEDs flash together	Wiring error for function selection (restart interlock, automatic mode)	Check connection at the receiver, bridge 1 or bridge 2 must be wired (refer to Wiring)
1 x flash	Wiring fault	Bridge operating mode, check wiring and signal level
2 x flashes	Fault with the external power supply	UB = 24V / DC ± 10%, power source and primary voltage check. A system reset is performed after three error indications.
3 x flashes	Error input contactor control	Check connection at contactor control input, check short-circuit to +UB and 0V. Check function status
4 x flashes	Errors at the OSSD outputs	Check the connections of both outputs, short-circuit of both OSSDs, connection to signal level 0V or 24V, deactivate cross-wire short monitoring downstream of the system inputs
5 x flashes	Error configuration data	Check and save the parameter setting with the BUS converter NSR-0801
6 x flashes	Error blanking	Check the blanked area(s) with the selected parameterisation, repeat the configuration in the parameter setting (PC software) and adapt if necessary
7 x flashes	Other errors, diagnostic	Restart the system, exchange components if there is a permanent fault diagnosis

6.3 Extended diagnostic

By means of the optional SLC 420 configuration software and the NSR-0801 BUS converter, an extended diagnostic can be executed. The software provides the status information of the component and can represent the individual light beams. This feature enables an optimal adjustment of the light curtain. The diagnostic mode is signalled by the OSSD ON and OSSD OFF LED's at the receiver. In diagnostic mode, protective mode is disabled, the ODDS outputs being locked. The change from diagnostic mode to protective mode is automatically realised after voltage reset, when the BUS converter is no longer integrated and the connecting cable of the sensor is reconnected.

7. Disassembly and disposal

7.1 Disassembly

The safety switchgear must be disassembled in a de-energised condition only.

7.2 Disposal

The safety switchgear must be disposed of in an appropriate manner in accordance with the national prescriptions and legislations.

8. Appendix

8.1 Contact

Consultancy / Sales:



K.A. Schmersal GmbH
 Industrielle Sicherheitsschaltssysteme
 Möddinghofe 30
 D-42279 Wuppertal
 Tel:+49 (0) 202 64 74 -0
 Fax:+49 (0) 202 64 74- 100

You will also find detailed information regarding our product variety on our website: www.schmersal.com

Repair handling / shipping:

Safety Control GmbH
 Am Industriepark 11
 D-84453 Mühldorf/ Inn
 Tel.: +49 (0) 8631-18796-0
 Fax: +49 (0) 8631-18796-1

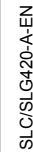
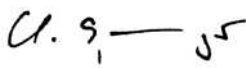
8.2 EC Declaration of conformity

	
<h2>EC Declaration of conformity</h2>	
Translation of the original Declaration of Conformity	Safety Control GmbH Am Industriepark 33 84453 Mühldorf / Inn Germany
<p>We hereby certify that the hereafter described safety components both in its basic design and construction conform to the applicable European Directives.</p>	
Name of the safety component / type:	SLC 420 / SLG 420 SLC 420 IP69K / SLG 420 IP69K (See ordering code)
Description of the safety component:	Safety light curtain / safety light grid
Relevant EC-Directives:	2006/42/EC EC-Machinery Directive 2004/108/EC EMC-Directive
Applied standards:	EN 61496-1, Type 4 EN 61496-2 EN ISO 13849-1; PL e EN 62061; SIL 3
Person authorised for the compilation of the technical documentation:	Oliver Wacker Möddinghofe 30 42279 Wuppertal
Notified body for the prototype test:	TÜV Nord Cert GmbH Langemarckstr. 20 45141 Essen ID n°: 0044
EC-prototype test certificate:	n° 44 205 13 1446 11
Place and date of issue:	Mühldorf, June 3, 2015
 SLC/SLG420-A-EN	 Authorised signature Christian Spranger Managing Director
	 Authorised signature Klaus Schuster Managing Director



The currently valid declaration of conformity can be downloaded from the internet at www.schmersal.net.



K.A. Schmersal GmbH & Co. KG
Möddinghofe 30, D - 42279 Wuppertal
Postfach 24 02 63, D - 42232 Wuppertal

Phone: +49 - (0)2 02 - 64 74 - 0
Telefax: +49 - (0)2 02 - 64 74 - 1 00
E-Mail: info@schmersal.com
Internet: <http://www.schmersal.com>