



EN Operating instructions. pages 1 to 18
Translation of the original operating instructions

4 Electrical connection
4.1 Wiring example blanking 12
4.2 Wiring example cyclic operation 13
4.3 Wiring example BDB 01 13
4.4 Wiring example BDT 01 14
4.5 Connector configuration Receiver, Emitter & Cable 15

5 Set-up and maintenance
5.1 Check before start-up 16
5.2 Maintenance 16
5.3 Regular check 16
5.4 Half-yearly inspection 16
5.5 Cleaning 16

6 Diagnostic
6.1 LED status information 16
6.2 Fault diagnostic 17

7 Disassembly and disposal
7.1 Disassembly 17
7.2 Disposal 17

8 Appendix
8.1 Contact 17
8.2 EC Declaration of conformity 18

Content

1 About this document
1.1 Function 1
1.2 Target group: authorised qualified personnel 1
1.3 Explanation of the symbols used 1
1.4 Appropriate use 1
1.5 General safety instructions 2
1.6 Warning about misuse 2
1.7 Exclusion of liability 2

2 Product description
2.1 Ordering code 2
2.2 Special versions 2
2.3 Scope of delivery and accessories 2
2.3.1 Accessories included in delivery 2
2.3.2 Optional accessories 2
2.4 Destination and use 3
2.5 Technical data 3
2.6 Response time (reaction time) 3
2.7 Effective resolution 4
2.8 Safety classification 4
2.9 Functions 4
2.9.1 Protective mode (Auto reset) 4
2.9.2 Restart interlock (manual reset) 4
2.9.3 Fixed blanking 4
2.9.4 Floating blanking 5
2.10 Setting of the functions: 6
2.11 Contactor control (EDM) 7
2.12 Start interlock 7
2.13 Testing 7
2.14 Beam coding 7
2.15 Operating mode cyclic operation 7

3 Mounting
3.1 General conditions 9
3.2 Protection field and approach 9
3.3 Alignment 9
3.4 Safety distance 9
3.4.1 Minimum distance to reflecting surfaces 10
3.5 Dimensions 11

1. About this document

1.1 Function
This operating instructions manual provides all the information you need for the mounting, set-up and commissioning to ensure the safe operation and disassembly of the safety switchgear. The operating instructions must be available in a legible condition and a complete version in the vicinity of the device.

1.2 Target group: authorised qualified personnel
All operations described in this operating instructions manual must be carried out by trained specialist personnel, authorised by the plant operator only.

Please make sure that you have read and understood these operating instructions and that you know all applicable legislations regarding occupational safety and accident prevention prior to installation and putting the component into operation.

The machine builder must carefully select the harmonised standards to be complied with as well as other technical specifications for the selection, mounting and integration of the components.

1.3 Explanation of the symbols used

 **Information, hint, note:**
This symbol is used for identifying useful additional information.

 **Caution:** Failure to comply with this warning notice could lead to failures or malfunctions.
Warning: Failure to comply with this warning notice could lead to physical injury and/or damage to the machine.

1.4 Appropriate use
The products described in these operating instructions are developed to execute safety-related functions as part of an entire plant or machine. It is the responsibility of the manufacturer of a machine or plant to ensure the correct functionality of the entire machinery or plant.

The safety switchgear must be exclusively used in accordance with the versions listed below or for the applications authorised by the manufacturer. Detailed information regarding the range of applications can be found in the chapter "Product description".

1.5 General safety instructions

The user must observe the safety instructions in this operating instructions manual, the country-specific installation standards as well as all prevailing safety regulations and accident prevention rules.



Further technical information can be found in the Schmersal catalogues or in the online catalogue on the Internet: www.schmersal.net.

The information contained in this operating instructions manual is provided without liability and is subject to technical modifications.



The entire concept of the control system, in which the safety component is integrated, must be validated to EN ISO 13849-2.

There are no residual risks, provided that the safety instructions as well as the instructions regarding mounting, commissioning, operation and maintenance are observed.

Additional measures could be required to ensure that the electro-sensitive device does not present a dangerous breakdown, when other forms of light beams are available in a special application (e.g. use of wireless control devices on cranes, radiation of welding sparks or effects of stroboscopic lights).

1.6 Warning about misuse



In case of inadequate or improper use or manipulations of the safety switchgear, personal hazards or damage to machinery or plant components cannot be excluded. The relevant requirements of the standards EN ISO 13855 (successor of EN 999) and EN ISO 13857 must be observed.

1.7 Exclusion of liability

We shall accept no liability for damages and malfunctions resulting from defective mounting or failure to comply with this operating instructions manual. The manufacturer shall accept no liability for damages resulting from the use of unauthorised spare parts or accessories.

For safety reasons, invasive work on the device as well as arbitrary repairs, conversions and modifications to the device are strictly forbidden; the manufacturer shall accept no liability for damages resulting from such invasive work, arbitrary repairs, conversions and/or modifications to the device.

2. Product description

2.1 Ordering code

This operating instructions manual applies to the following types:

SLC 421-E/R^①-②-RFBC-③

No.	Option	Description
①	xxxx	Protection field heights in mm available lengths: 0170, 0250, 0330, 0410, 0490, 0570, 0650, 0730, 0810, 0890, 0970, 1050, 1130, 1210, 1290, 1370, 1450, 1530*, 1610*, 1690*, 1770*
②	14, 30	Resolution 14, 30 mm
③	01	Status display OSSD on/off

Note

* only for resolution 30 mm



Only if the information described in this operating instructions manual are realised correctly, the safety function and therefore the compliance with the Machinery Directive is maintained.

2.2 Special versions

For special versions, which are not listed in the order code below 2.1, these specifications apply accordingly, provided that they correspond to the standard version.

2.3 Scope of delivery and accessories

2.3.1 Accessories included in delivery

Mounting kit MS-1030

The kit comprises 4 rotating mounting angles and 16 mounting screws for fixing to the end caps.

Test rod PLS

The test rod is used for testing the protection field.

2.3.2 Optional accessories

Centre fixing MS-1051

Consisting of 2 steel angles, 4 fixing screws and 4 T-slot nuts

Connecting cable for transmitter

Item number	Designation	Description	Length
1207741	KA-0804	Female connector M12, 4-pole	5 m
1207742	KA-0805	Female connector M12, 4-pole	10 m
1207743	KA-0808	Female connector M12, 4-pole	20 m

Connecting cable for receiver

Item number	Designation	Description	Length
1213352	KA-0980	M12, 12-pole straight (Female)	5 m
1213353	KA-0981	M12, 12-pole straight (Female)	10 m

Connecting cable for external control unit

Item number	Designation	Description	Length
1213354	KA-0053	M8, 6 poles angled 90°	2 m
1213355	KA-0054	M8, 6 poles angled 90°	5 m

External control unit BDB 01

External control unit BDB 01 for the fast parameter assignment of the fixed and floating blanking function with external command devices.

Robust - Box BDB 01 with command devices

S1 = key-operated selector switch 2 NC contacts / 2 NO contacts

S2 = selector switch 2 NC contacts / 4 NO contacts

S3 = restart interlock (manual reset) enabling button

Connection = cable gland - 8-pole cable, L = 5.0 m

Dimension: 160 x 80 x 85 (L x W x H) mm

External control unit BDT 01

External control unit BDT 01 for the fast parameter assignment of the cyclic functions with external command devices

Robust - Box BDT 01 with command devices

S1 = key-operated selector switch 2 NC contacts / 4 NO contacts

S2 = teach-in button

S3 = restart interlock (manual reset) enabling button

Connection = cable gland - 6-pole cable, L = 5.0 m

Dimension: 160 x 80 x 85 (L x W x H) mm

MSD4 Vibration damper

Kit consisting of: 8 vibration dampers 15 x 20 mm, 8 M5 cylinder head screws with hexagon socket, 8 spring washers

The MSD4 vibration damper kit must be used for damping vibrations and oscillations on the SLC 421. For applications with higher mechanical stresses, e.g. presses, punching machines, we recommend the MSD4 kit. In this way, the availability of the SLC 421 is increased.

2.4 Destination and use

The SLC 421 is a non-contact, self-testing safety guard, which is used for the protection of hazardous points, hazardous areas and machine accesses. If one or more light beams are interrupted, the hazardous movement must be stopped.



The user must evaluate and design the safety chain in accordance with the relevant standards and the required safety level.

2.5 Technical data

Standards:	EN 61496-1; CLC/TS 61496-2; EN ISO 13849; EN 62061
Material of the enclosure:	Aluminium
Enclosure dimensions:	ø 49 mm
Number of beams:	8 ... 144 Beams
Protection field heights:	170 ... 1450 mm, Resolution 14 mm (170, 250, 330, 410, 490...), 170 ... 1770 mm, Resolution 30 mm (170, 250, 330, 410, 490...)
Detection sensitivity for test bodies:	14 mm, 30mm
Range of the protection field:	0.3 ... 7.0 m; (Resolution 14 mm), 0.3 ... 10.0 m; (Resolution 30 mm)
Response time:	1 - 48 L = 10 ms, 49 - 144 L = 20 ms without beam coding A, 1 - 48 L = 15 ms, 49 - 144 L = 27 ms with beam coding A
Rated operating voltage:	24 VDC ±10% (PELV) supply unit to EN 60204 (power drop > 20 ms)
Operating current:	400 mA max. + 0.5 A (OSSD load + output signal quality load)
Wave length of the sensor:	860 nm
Safety outputs (OSSD1, OSSD2):	2 x PNP-type semi-conductor, short-circuit proof
Switching voltage HIGH ¹⁾ :	15 ... 28,8 V
Switching voltage LOW ¹⁾ :	0 ... 2 V
Switching current:	0 ... 500 mA
Leakage current ²⁾ :	1 mA
Load capacity:	2 µF
Load inductance:	2 H
Admissible conduction resistance between OSSD and load:	2.5 Ω
Supply cable:	1 Ω
Contact control (EDM)	
Input voltage HIGH (inactive):	17 ... 29 V
Input voltage LOW (active):	0 ... 2.5 V
Input current HIGH:	3 ... 10 mA
Input current LOW:	0 ... 2 mA
Input restart interlock (manual reset)	
Input voltage HIGH (active):	17 ... 29 V
Input voltage LOW (inactive):	0 ... 2.5 V
Input current HIGH:	3 ... 10 mA
Input current LOW:	0 ... 3 mA
Function SLC 421:	Start and restart interlock (manual reset), contactor control, fixed and mobile beam blanking, cyclic operation 1 or 2 cycles
Signal times	
Contact control:	50 ... 500 ms, einstellbar
Restart interlock (manual reset):	50 ms ... 1.0 s signal trans- mission in case of trailing edge
Start interlock:	250 ... 1500 ms, adjustable
LED indications transmitter:	Transmitting, status
LED indications receiver:	OSSD ON, OSSD OFF, restart, signal reception, blanking, multifunction
Connection:	Connector plug with metal thread, receiver M12, 12-pole and M8, 6-pole, transmitter M12, 4-pole (male)
Ambient temperature:	-10° C ... +50° C
Storage temperature:	-25° C ... +70° C
Interface:	Diagnostics and function setting
Protection class:	IP67 (IEC 60529)
Resistance to vibrations:	10 ... 55 Hz to IEC 60068-2-6
Resistance to shock:	10 g; 16 ms; to IEC 60068-2-29
Year of construction:	as of 2010 version 1.0

¹⁾ To IEC 61131-2

²⁾ In case of failure, the leakage current at the most flows to the OSSD cable. The downstream control element must recognise this state as LOW. A safety PLC must detect this state.

2.6 Response time (reaction time)

Standard version

The response time depends on the height of the protected field, the resolution, the number of light beams and the beam coding.

Resolution 14 mm				
Protected height [mm]	Beams [Number]	Response time [ms]	Response time with beam coding A [ms]	Weight [kg]
170	16	15	20	1.0
250	24	15	20	1.3
330	32	15	20	1.6
410	40	15	20	1.9
490	48	15	20	2.1
570	56	25	32	2.4
650	64	25	32	2.6
730	72	25	32	2.9
810	80	25	32	3.2
890	88	25	32	3.5
970	96	25	32	3.7
1050	104	25	32	4.0
1130	112	25	32	4.3
1210	120	25	32	4.6
1290	128	25	32	4.7
1370	136	25	32	5.1
1450	144	25	32	5.3

Resolution 30 mm				
Protected height [mm]	Beams [Number]	Response time [ms]	Response time with beam coding A [ms]	Weight [kg]
170	8	15	20	1.0
250	12	15	20	1.3
330	16	15	20	1.6
410	20	15	20	1.9
490	24	15	20	2.1
570	28	15	20	2.4
650	32	15	20	2.6
730	36	15	20	2.9
810	40	15	20	3.2
890	44	15	20	3.5
970	48	15	20	3.7
1050	52	25	32	4.0
1130	56	25	32	4.3
1210	60	25	32	4.6
1290	64	25	32	4.8
1370	68	25	32	5.1
1450	72	25	32	5.3
1530	76	25	32	5.6
1610	80	25	32	5.9
1690	84	25	32	6.2
1770	88	25	32	6.4

2.7 Effective resolution

The effective resolution in case of activated blanking can be found in the following table:

Blanked beams	Physical resolution	Effective resolution
1	14	24
2	14	34
3	14	44
4	14	54
5	14	64
6	14	74
7	14	84
8	14	94

Blanked beams	Physical resolution	Effective resolution
1	30	45
2	30	65
3	30	85
4	30	105

2.8 Safety classification

Standards:	EN ISO 13849-1, EN 62061
PL:	up to e
Control category:	up to 4
PFH value:	$7.42 \times 10^{-9} / h$
SIL:	up to 3
Service life:	20 years

2.9 Functions

The system consists of a receiver and a transmitter. For the described functions, no further switching elements are required. For the diagnostics and function selection, a user-friendly PC-software is offered as accessory.

For the connection to a PC, the NSR-0801 BUS converter is required (not included in delivery).

The system has the following features:

- Protective mode (automatic start after release of the protected field)
- Start interlock
- Restart interlock (manual reset)
- Contactor control EDM
- Beam coding
- Blanking of fixed protection field areas
- Blanking of movable protection field areas
- Cyclic operation

Factory setting

The system features many functions without needing any additional devices. The following table gives an overview of the possible functions and the factory settings configuration.

Function	Factory setting	Configuration
Start interlock	not active	BUS converter NSR-0801
Protective mode	not active	Wiring example
Restart interlock (manual reset)	not active	Wiring example
Contactor control	not active	Wiring example
Beam coding	not active	BUS converter NSR-0801
Blanking of fixed/moving objects	not active	External command devices
Cyclic operation	not active	External command devices

2.9.1 Protective mode (Auto reset)

The protective mode switches the OSSD outputs to ON state (protection field not interrupted), without external release of a switching device. This type of protection generates an automatic restart of the machine if the protection field is not interrupted.



The protective mode is not available in the operating mode "cyclic function".



This operating mode may only be chosen in conjunction with the restart interlock of the machine. This operating mode must not be chosen, when persons can step behind the protection field.

2.9.2 Restart interlock (manual reset)

The restart interlock prevents an automatic enabling of the outputs (OSSD's ON state) after switch-on of the operating voltage or an interruption of the protection field. The system switches the outputs only to ON state, when an external command device (restart button) generates an enabling signal at the restart input (receiver).



The command devices (enabling button) must be installed outside of the hazardous area. The operator must have a clear view on the hazardous area when actuating the enabling button.



In supply condition, the restart interlock neither the protective mode is active. You must choose one of both operating modes to enable the OSSD outputs. If no type of protection is selected, you will obtain the following signalisation through the LED status indication in the receiver:

LED OSSD OFF (red) + LED restart (yellow) flashing

2.9.3 Fixed blanking

The SLC 421 safety light curtain enables a flexible adjustment to machinery operating with stationary and/or mobile parts in the protection field. The parameter assignment is realised by means of a key-operated and selector switch without any other tools whatsoever, such as additional external control devices or PC software through a PC.

The required blanking of beams or beam ranges for the operating mode regarded is realised through the parameter assignment of the command devices and a foot switch. In parameter assignment mode, the following functions are available.

- Fixed blanking (option: additional blanking of 1 or 2 light beams)
- Fixed and/or floating blanking with additional blanking of 1 or 2 light beams

This function can blank fixed parts in the protection field (e.g. workpiece supports). The blanked beams or areas can be arbitrarily defined in accordance with the requirements. The first light beam (immediately behind the diagnostic field), which is used for the beam synchronisation, cannot be blanked. The permanently blanked light beams are dark monitored, i.e. if the IR light of the emitter falls onto the receiver, which is blanked, the OSSD outputs are disabled. Tolerance ranges of the object, for instance with half-covered light beams, can be taken into consideration (1 or 2 additional light beams).

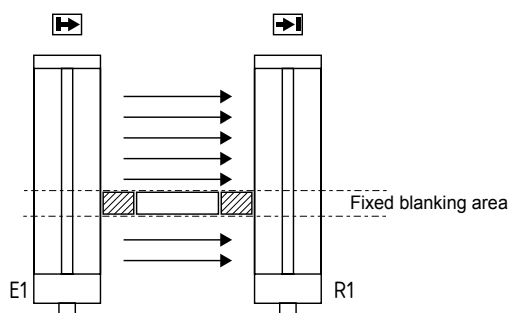

The area of the fixed blanking must not be modified after the teach-in process. Any change of the area or removal of the part from the protection field will be detected by the system. As a result, the outputs are disabled (locked). This locking can be neutralised by executing a new teach-in process in accordance with the actual beam interruptions.



- The remaining lateral areas must be protected against intrusion by means of mechanical covers.
- The lateral covers must be fixed with the object.
- Partial covers are not authorised.
- After the fixed blanking, the protection field must be tested by means of the test rod.
- The restart interlock function of the safety light curtain or the machine must be activated.

2.9.4 Floating blanking

This function enables a combination of fixed and floated beam blanking. The floating beam blanking enables the teach-in of object movements (e.g. processing of steel plates) in the protection field. The non-stationary object thereby can move inside and outside of the protection field (floating blanking). Tolerance ranges of the object, for instance with half-covered light beams, can be taken into consideration with floating blanking (1 or 2 additional light beams).

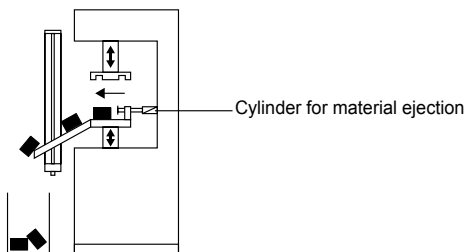

In the application example, the light curtain is parameterized with fixed blanking for the stationary conveyor belt and with floating blanking for the material ejection.

The function enables an arbitrary floating blanking of partial areas in the protection field. The first beam, which is located immediately behind the diagnostic window, cannot be blanked.

This function allows for an interruption of the protection height without the outputs being disabled in case of material movement in the protection field, e.g. material ejection or process-controlled material movement. In this way, the physical resolution changes into an effective resolution. This effective resolution must be used to calculate the safety distance. This effective resolution must be used to calculate the safety distance. Use formula (2) to calculate the safety distance with the effective resolution if a maximum of 1 light beams are blanked; use formula (2) indicated in the "Safety distance" chapter if more than 3 light beams are blanked.



Perform a new calculation of the safety distance with the effective resolution. Adjust the safety distance in accordance with your calculation!
The effective resolution must be mentioned permanently and well visibly on the information label of the receiver.

Parameter assignment using external command devices

Both command devices (key-operated switch and selector switch) are switches with 2 or 3 positions with 2-pole NO contacts each. The foot switch is a 1-pole version (NO contact) and so is the restart interlock enabling button.

Instead of connecting the individual command devices, the BDB 01 control unit with integrated key-operated and selector switch and restart interlock enabling switch in a robust enclosure can be used. More information regarding the BDB 01 control unit can be found in the "Accessories" chapter.

Set-up: blanking operating mode

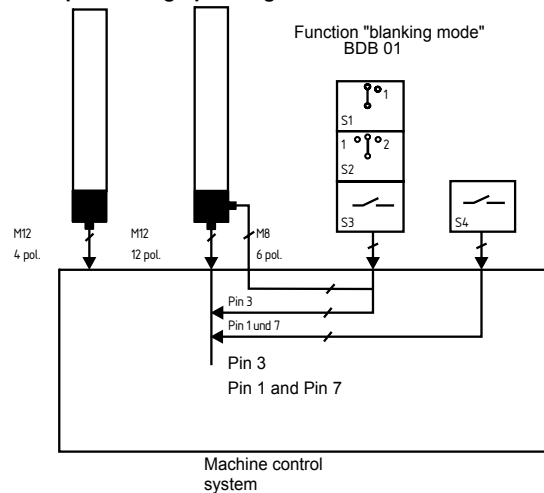

Wiring of the SLC 421/R receiver:

M12 female connector, 12-pole,
M8 female connector, 6-pole, front

External control unit BDB 01

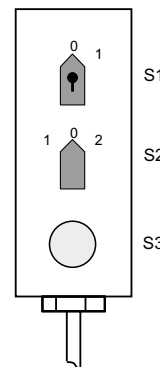

Command devices legend:

- S1 = Key-operated switch
- S2 = Selector switch
- S3 = Restart interlock (manual reset) enabling button
- S4 = Foot switch
- BDB 01 = Blanking control unit

2.10 Setting of the functions:

Fixed and floating blanking through key-operated switch with 2 positions

Position of the key-operated switch	0	1
Function	Light curtain	Parameter assignment mode
(the key can only be withdrawn in position 0)	Normal operating mode	Beam blanking of fixed and mobile range(s)

Floating blanking of additional light beams through switch with 3 positions

Switch position	0	1	2
Function	Floating blanking of additional light beams deactivated	Floating blanking with one additional light beam	Floating blanking with two additional light beams

Position 1) The additionally blanked light beam can freely move in the protection field

Position 2) The additionally blanked light beams can freely move in the protection field.

The light curtain selects the "parameter assignment" operating mode of the blanking functions by means of the BDB 01 control unit or the external command devices, when the signal inputs are correctly wired through the additional M8 6-pole connector after the supply voltage is switched on. (Both command devices must be in position "0"). Wiring errors are signalled by the red LED permanently flashing. The signal inputs at pin 11 and 12 must not be wired (input open). If the "parameter assignment blanking" operating mode is not activated, the wiring must be checked and the system must be restarted (switch the supply voltage ON/OFF). The wiring must be realised to the wiring diagram. Faulty executions, e.g. inversion of the input signals of the command devices, can lead to hazardous operating conditions.

Position of the command device for the "parameter assignment" operating mode

The object to be taught must be positioned in the protection field. Depending on the desired light beam blanking, the following blanking functions are available:

The corresponding key must be inserted into the key-operated switch (S1) in switching position "0". The operating mode can only be switched to parameter assignment mode, when both command devices (key-operated switch and selector switch) are in switching position "0".

The parameter settings can only be saved within a timeframe of 3 minutes after the key-operated switch S1 has been turned from position "0" to position "1" or "2". (Timeframe signalled by the LED "OSSD ON" and "OSSD OFF" synchronously flashing). If the time window is exceeded, a reset is required (signalled by the LED "OSSD OFF" permanently flashing). A reset is realised by switching the key-operated switch S1 for at least 1.5 seconds to position "0".

Mode 1 - Fixed blanking with the optional additional blanking of 1 or 2 light beams

If the key-operated switch is switched to position "1", the system switches within one second to the operating mode "parameter assignment" (shown by the LED's "OSSD ON" and "OSSD OFF" simultaneously flashing). The OSSD outputs of the light curtain are disabled and locked.

If the key-operated switch is switched to position "1", a fixed blanking (one or more arbitrary object height(s)) with stationary position in the

protection field can be activated. These are "dark" monitored (interruption is operational condition)!

In switching position "0" of the selector switch, only a fixed blanking of the light beams is realised; all interruptions of the light beams exceeding the object size will therefore lead to the outputs being disabled. A combination with floating beam blanking can be activated by turning the selector switch (S2) in position "1" or position "2".

The floating beam blanking is also available without fixed beam blanking, if no beams are interrupted during the teach-in procedure.

Saving the desired configuration

To save the desired configuration, the foot switch must be actuated 1x (actuate the foot switch up to the mechanical limit and release within 1.5 seconds). The LED "OSSD ON" flashes permanently green during the saving procedure of the configuration.

During the teach-in process, all beams that are interrupted at the time of the trailing edge of the foot switch are blanked; the settings of selector switch S2 are copied.

Parameter assignment/function at the LED status window		
LED blue	1 flash	Fixed blanking of the protection field(s)
	2 flash	Floating blanking of 1 light beam
	3 flash	Floating blanking of 2 light beams
	4 flash	Floating (max. 1 beam) and fixed blanking of protection field(s)
LED red	5 flash	Floating (max. 2 beams) and fixed blanking of protection field(s)
	Permanent flashing	Parameter assignment fault, functional flow or time-out
	1..5 x flashes	Refer to table LED OSSD OFF (red) fault diagnostic
	6 flash	Fault monitoring - light beams with fixed blanked light beams, parameter reassignment

e.g. blue LED 4 x flashing - corresponds to: fixed blanking + 1 beam with floating blanking



If the above-mentioned sequence is not correctly executed, the floating beam blanking is not saved. Any inadvertent incidental saving of a floating beam blanking followed by a new saving procedure without beam interruption is reset.

Switching from parameter assignment mode to normal operation

After the desired parameter assignment of the protection field is terminated, both command devices, the S1 key-operated switch and the S2 selector switch must be positioned in position "0". In this way, the parameter assignment mode is closed and the light curtain is switched to normal operation.

When the restart interlock enabling button is actuated (max. 1.5 seconds, negative edge), the protection field is activated in accordance with the parameter assignment and the light curtain is switched to ON state (restart interlock mode). In protection mode, the start interlock must be acknowledged (refer to chapter "Start interlock").

Condition: the non-blanked light beams in the protection field are free, fixed blanked and the marked light beams are actuated, both command devices (S1, S2) are in position "0".

Operating condition upon the signal change of the external switchgear
Changes to the position of the selector switch S2 or a signal impulse from the foot switch do not affect the last successfully saved operating condition. The operating condition is maintained until a new teach-in procedure is correctly executed and terminated.

If light beams (with fixed blanking), which are blanked by the receiver, are detected as non-actuated, the operating condition of the outputs changes to OFF/error mode (LED OSSD OFF red, flashes 6x). This fault condition is reset by a parameter reassignment (teach in). The saved functions (blankings) thereby are deactivated.

A voltage drop or the reset of the light curtain deletes the last teach-in process and results in an operating condition without beam blanking.

2.11 Contactor control (EDM)

The contactor control monitors the controlled switching elements (auxiliary contacts of the contactors) of both outputs. This monitoring is realised after each interruption of the protection field and prior to the restart (enabling) of the outputs. In this way, malfunctions of the relays are detected, e.g. contact welding or contact spring breakage. If the light curtain detects a malfunction of the switching elements, the outputs are locked.

After fault rectification, the operating voltage must be once switched off and back on (power reset).

The auxiliary contacts must only be wired if the contactor control is activated.



Upon delivery, the "contactor control" function is deactivated. Activating the function: refer to chapter 4.5.

Activation of the contactor control (EDM) without software

The contactor control can be activated without PC software as of firmware version 1.23, by means of cable bridges (refer to wiring diagram).

2.12 Start interlock

The start interlock prevents the automatic start of the machine (OSSD's ON) after the supply voltage is switched on or after the parameter assignment by means of command devices. The start interlock is signaled in the diagnostic field by means of the permanent yellow signal of the LED installed on the receiver. After enabling, the protection mode is available.

The start interlock is deactivated by the one-time interruption of the active protection field. To that effect, at least one active light beam must be interrupted within a max. periode of time of 1.5 seconds (light beam interrupted and released). In the absence of an enabling signal, the procedure must be repeated.

The start interlock can be deactivated in special cases and exceptions. An automatic start of the machine after a voltage reset/parameter assignment must be ensured by at least equivalent protective measures.



The start interlock is not activated upon delivery. This function is activated by means of the NSR-0801 BUS converter and a PC or laptop.

2.13 Testing

The system performs a complete self-test and safety test within 2 seconds after the operating voltage has been switched on. If the protection field is not interrupted, the system switches to the ON condition. In case of an error, the outputs at the receiver do not switch to the ON state. The LED OSSD OFF starts flashing, thus emitting an error message. Further indications can be found in the chapter Fault diagnostic.

During operation, the system continuously executes a self-test. Safety-relevant faults are detected within the cycle time and cause the outputs to be switched off.

2.14 Beam coding

The beam coding of the safety light curtain must be adjusted, when systems operating in each other's vicinity and a set-up as shown in the image below (no interference) is impossible. When supplied, the beam coding is not active. With beam coding A, a receiver can distinguish the beams of the transmitter with the same beam coding, which are destined to this particular receiver, from foreign beams. The beam coding A must be set for each sensor (receiver and transmitter) individually. The function is activated by means of the NSR-0801 BUS converter and a PC or laptop. If adjacent systems are operated without beam coding, the user is at risk.

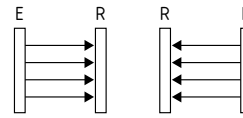

no interference

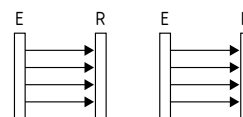

Interference: beam coding required!

- The beam coding increases the safety and avoids mutual interference of adjacent systems.
- The beam coding increases the immunity against optical interference (e.g. sun light, welding sparks).
- The beam coding A is permanently shown by the transmitter and the receiver by means of flashing LED's (refer to LED status information).



The response time of the system is increased when beam coding A is used. To this end, the safety distance must be adjusted to the hazardous movement. Refer to chapter Response time.

2.15 Operating mode cyclic operation

2 cycles are available. These can be parameterised using the "key selector switch" command device (S1).

Adequate and appropriate application

The cyclic operation must be used for machines with short processing times. The function enables an automatic work sequence by the cyclic feed and removal of parts in the protection field of the SLC 421. The automatic sequence is time-monitored. In this way, up to 2 work-pieces (2 interventions in the protection field) can be processed at the same time.



This function is only authorised for the above-described application. For other applications, no warranty claims shall be accepted. No liability shall be accepted either when the following mounting conditions, safety instructions and correct parameter setting are not respected and observed. In a few countries outside of the EC, the cyclic function is not authorised as operating mode.

Operating principle cyclic operation

The operator interventions (N) (1) in the protection field during the first machine cycle are not evaluated. The start condition for the first cycle is active after the actuation of the start button (2) and both operator interventions (3) for the 2-cycle operation. Through the operator interventions, the OSSD outputs (3) are enabled. The downward movement of the machine (hazardous machine movement) will take place. during the hazardous work cycle, all interventions of the operator will cause the outputs to be disabled. If the hazardous movement of the machine is terminated, the machine contact (4) will be opened and the outputs (4) will be disabled. The signal length of the machine contact is monitored and must be present for at least 50ms. The following operator interventions (5) are taken into consideration as next cycle. The correct number of operator interventions (5) will start a new work cycle, thus re-enabling the outputs (6). The machine contact (7) will terminate the hazardous movement and disable the OSSD outputs (7).

Schema: two-cycle operation

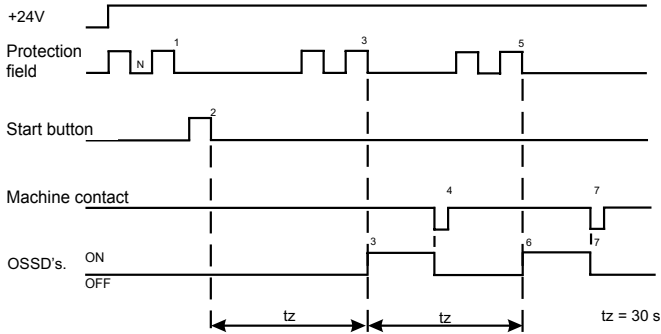

Machine contact = signal impulse 4 for hazardous movement of the machine is terminated

Machine contact

The machine contact is a signal, which is transmitted from the machine control to the SLC 421. This contact is used for the cycle reset and enables an immediate intervention in the protection field. The signal is integrated in the control system of the SLC 421 with the status information - The hazardous movement is terminated!

The signal is preferably provided after the end of the downward movement (UT) to the switching diagram, when no hazardous movement is produced during the upward movement.

The machine contact as single contact will suffice. The machine contact has a signal length of at least 50 ms and 1 s at the most. If the machine contact is not closed again within the time window (ON signal), no new cycle will be started.

The machine contact must be connected to the SLC 421 by means of a separate cable (at least 2 poles).

Start conditions

First actuate the start button and then execute the operator interventions.

The start condition must be executed:

- prior to the first machine cycle after the supply voltage is switched on,
- false intervention in the protection field,
- cycle time exceeded,
- false machine contact or time window exceeded

Further machine cycles are only controlled by the operator interventions.

The time between the operator intervention and the actuation of the start button may be max. 30 sec. at the most.

Cycle time

The cycle time is the time between two successive cycles, i.e. interventions in the protection field (material feed and removal). The cycle time is reset by actuating the enabling command device or by starting a new work process. Upon delivery, the cycle time is set to 30 sec.

Operator interventions

The operator interventions in the protection field are counted and time-monitored in accordance with the setting. To prevent unintentional operator interventions, the minimum time of 100 ms must be observed for an intervention in the protection field (beam interrupted and cleared).

Parameter assignment using external command devices:

The flexible adjustment to the different machine cycles can be smoothly realised by means of the command devices or the BDT 01 control unit.

Set-up with BDT 01 control unit

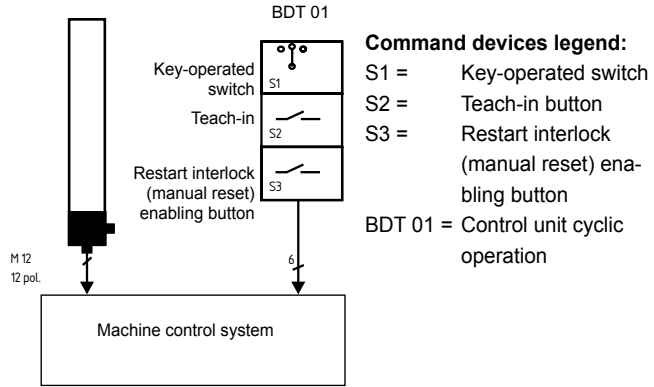

Cyclic operation with external command devices:

The parameter assignment of the cyclic function is available, when the terminals of the external command devices (key-operated switch - cyclic operation, machine signal) are correctly wired and the key-operated switch is in position 0 after the supply voltage is switched on. The restart interlock operating mode must be configured for the cyclic operation (refer to wiring diagram cyclic operation).

The additional signal inputs at the M8/6-pole connector of the receiver must not be wired. If the cyclic operation mode is not available, the wiring must be checked and the system must be restarted (supply voltage ON/OFF) (fault signalling: red LED permanently flashing). If no additional command devices are connected for the function selection, the normal operating mode of the light curtain with protection mode/ restart interlock is available.

Parameter assignment cyclic operation (no cyclic operation, 1 cycle or 2 cycles)			
Position of the key-operated switch	0	1	2
Cyclic function (the key can only be withdrawn in position 0)	Normal operating mode without cyclic function	1-Cyclic operation	2-Cyclic operation

Parameter assignment by means of key-operated switch:

The corresponding key must be inserted into the key-operated switch in switching position "0". If one of the two switching position (Pos 1 or Pos 2) is selected, the light grid will change from normal operating state to parameter setting mode. (Signaling: "OSSD ON" and "OSSD OFF" LED synchronously flashing). Both OSSD outputs of the light grid will be disabled and locked.

Saving the selected parameter assignment in diagnostic mode / teach-in

If the teach-in button is actuated (max. 1.5 seconds, negative edge), the new operating mode is saved in accordance with the switching position of the key-operated switch (no cycle, 1 cycle or 2 cycles). If the setting is successfully saved, the LED "OSSD ON" will permanently flash green.

The parameter settings can only be saved within a timeframe of 3 minutes after the key-operated switch S1 has been turned from position "0" to position "1" or "2". (Timeframe signalled by the LED "OSSD ON" and "OSSD OFF" synchronously flashing).

If the time window is exceeded, a reset is required (signalled by the LED "OSSD OFF" permanently flashing). A reset is realised by switching the key-operated switch S1 for at least 1.5 seconds to position "0".

Switching from parameter assignment mode to normal operation:
After termination of the teach-in procedure, the key-operated switch must be position in position "0" regardless of the chosen parameter assignment. In this way, the parameter assignment is terminated and the normal operating mode of the light curtain is activated.

If the restart interlock enabling button is actuated (max. 1.5 seconds, negative edge), the cyclic function is started in accordance with the definitive sequence in this operating mode.

A voltage drop or the actuation of the key-operated switch in position "1" or "2" deletes the previous parameter assignment and leads to an operating condition without cyclic operation.

3. Mounting

3.1 General conditions

The following guidelines are provided as a preventative warning notice to ensure safe and appropriate handling. These guidelines are an essential part of the safety instructions and therefore must always be observed and respected.



- The SLC must not be used on machines, which can be stopped electrically in case of emergency.
- The safety distance between the SLC and a hazardous machine movement must always be observed and respected.
- Additional mechanical safety guards must be installed so that the operator has to pass by the protection field to reach the hazardous machine parts.
- The SLC must be installed so that the personnel always must be within the detection zone when operating the machine. An incorrect installation can lead to serious injuries.
- Never connect the outputs to +24VDC. If the outputs are wired to +24VDC, they are in ON state, as a result of which they are unable to stop a hazardous situation occurring on the application/machine.
- The safety inspections must be conducted regularly.
- The SLC must not be exposed to inflammable or explosive gasses.
- The connecting cables must be connected in accordance with the installation instructions.
- The fixing screws of the end caps and the mounting angle must be firmly tightened.

3.2 Protection field and approach

The protection field of the SLC consists of the entire range located between the protection field markings of transmitter and receiver. Additional protective devices must ensure that the operator has to pass by the protection field to reach the hazardous machine parts.

The SLC must be installed so that personnel are always located within the detection zone of the safety device when operating the hazardous machine parts to be secure.



The command devices must be installed outside of the hazardous area. The operator must have a clear view on the hazardous area when actuating the enabling button.

The command devices must have at least IP 54 or be fitted in an IP 54 control cabinet.

The BDB & BDT command devices, available as accessory, meet protection class IP 40. Do not install the control unit on machinery requiring a higher protection class e.g. environments with splashed or spraying water.

Correct installation



Hazardous machine parts can only be reached after passing through the protection field.

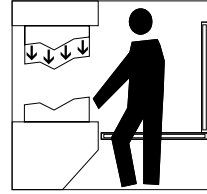

The presence of staff members between the protection field and hazardous machine parts must be prevented/avoided (protection against stepping over).

Unauthorised installation

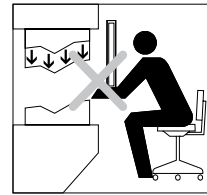

Hazardous machine parts can be reached without passing through the protection field.

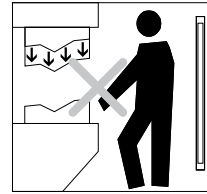

The presence of staff members between the protection field and hazardous machine parts is enabled.

3.3 Alignment

Procedure:

1. The transmitter and the receiver must be fitted parallel to each other and at the same height.
2. Turn the transmitter and monitor the diagnostic window of the receiver. Fix the light curtain, when the LED OSSD ON (green) is on and the LED signal reception (orange) is off.
3. Determine the max. rotating angle to the left and to the right, at which the LED OSSD ON (green) is on and tighten the mounting screws in central position. Make sure that the LED signal reception (orange) is not on or flashing.

3.4 Safety distance

The safety distance is the minimum distance between the protection field of the safety light curtain and the hazardous area. The safety distance must be observed to ensure that the hazardous area cannot be reached before the hazardous movement has come to standstill.

Calculation of the safety distance to EN ISO 13855 (successor of EN 999) and EN ISO 13857

The safety distance depends on the following elements:

- Run-on time of the machine (calculation by run-on time measurement)
- Response time of the machine and the safety light curtain and the downstream relay (entire safety guard)
- Approach speed
- Resolution of the safety light curtain

Safety light curtain SLC 421

The safety distance for resolutions 14 mm up to 40 mm is calculated by means of the following formula:

$$(1) S = 2000 \text{ mm/s} * T + 8 (d - 14) \text{ [mm]}$$

S = Safety distance [mm]

T = Total reaction time (machine run-on time, reaction time of the safety guard, relays, etc.)

d = Resolution of the safety light curtain

The approach speed is covered with a value of 2000 mm/s

If value $S \leq 500$ mm after the calculation of the safety distance, then use this value.

If value $S \geq 500$ mm, recalculate the distance:

$$(2) S = 1600 \text{ mm/s} * T + 8 (d - 14) \text{ [mm]}$$

If the new value $S > 500$ mm, use this value as safety distance.

If the new value $S < 500$ mm, use a minimum distance of 500 mm.

Example:

Reaction time of the safety light curtain = 10 ms

Resolution of the safety light curtain = 14 mm

Run-on time of the machine = 330 ms

$$S = 2000 \text{ mm/s} * (330 \text{ ms} + 10 \text{ ms}) + 8(14 \text{ mm} - 14 \text{ mm})$$

$$S = 680 \text{ mm}$$

$$S > 500 \text{ mm, therefore new calculation with } V = 1600 \text{ mm/s}$$

$$S = 544 \text{ mm}$$

The safety distance for resolutions 41 mm up to 70 mm is calculated by means of the following formula:

$$(3) S = (1600 \text{ mm/s} * T) + 850 \text{ mm}$$

S = Safety distance [mm]

T = Run-on time of the machine + reaction time of the safety light curtain

K = Approach speed 1600 mm/s

C = Safety supplement 850 mm



If the effective resolution is more than 70 mm, the detection of bodily parts is no longer guaranteed; to that end, the risks such as reaching into, climbing through and reference heights above the ground must be observed (refer to EN ISO 13855). The formula (3) is also applicable to the calculation of the safety distance for the effective resolution from 41 mm to 300 mm.



The safety distance between the safety light curtain and the hazardous point must always be respected and observed. If a person reaches the hazardous point before the hazardous movement has come to standstill, he/she is exposed to serious injuries.

Safety distance to the hazardous area

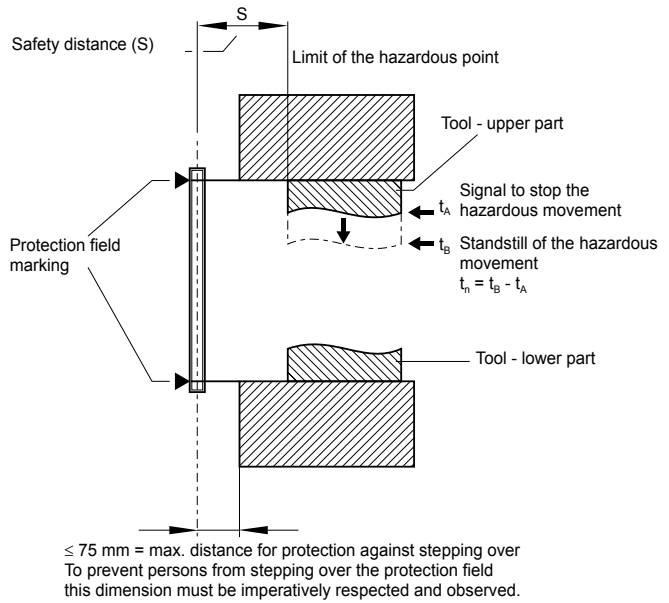

The formulae and calculation examples are related to the vertical set-up (refer to drawing) of the light curtain with regard to the hazardous point. Please observe the applicable harmonised EN standards and possible applicable national regulations.



The successor standards of the EN 999 for calculating the minimum distances of the safety guards with regard to the hazardous point are EN ISO 13855 and EN ISO 13857.

3.4.1 Minimum distance to reflecting surfaces

During the installation, the effects of reflecting surfaces must be taken into account. In case of an incorrect installation, interruptions of the protection field could possibly not be detected, which could lead to serious injuries. The hereafter-specified minimum distances with regard to reflecting surfaces (metal walls, floors, ceilings or parts) must be imperatively observed.

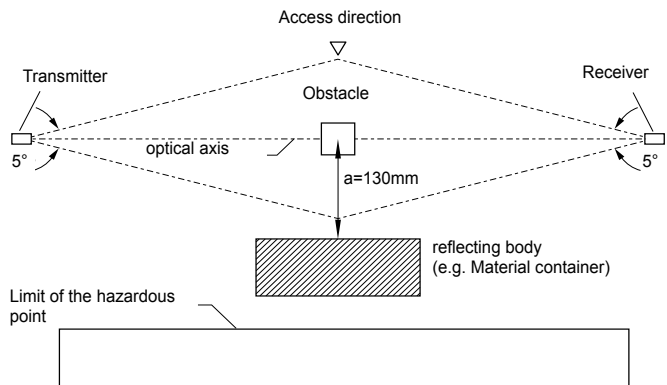

Safety distance a

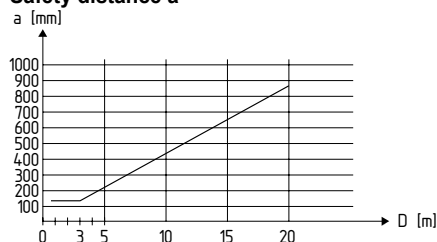

Calculate the minimum distance to reflecting surfaces as a function of the distance with an aperture angles of $\pm 2.5^\circ$ degrees or use the value from the table below

Distance between transmitter and receiver [m]	Minimum distance a [mm]
0.2 ... 3.0	130
4	175
5	220
7	310
10	440
15	660

Formula: $a = \tan 2.5^\circ \times L$ [mm]

a = Minimum distance to reflecting surfaces
L = Distance between transmitter and receiver

3.5 Dimensions

All measurements in mm.

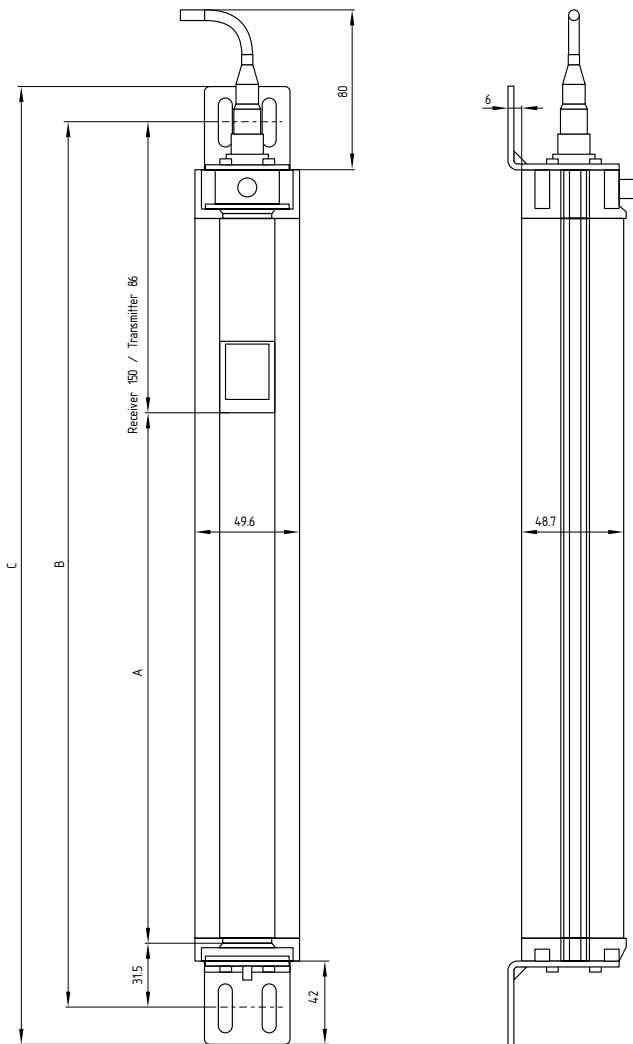

Legend:

- A Protected height $\pm 0,1$
- B Mounting dimension ± 1
- C Total length ± 1

Type	A	B	C	
			Transmitter	Receiver
SLC 421-E/R0170-XX-RFBC	170	288	352	388
SLC 421-E/R0250-XX-RFBC	250	368	432	468
SLC 421-E/R0330-XX-RFBC	330	448	512	548
SLC 421-E/R0410-XX-RFBC	410	528	592	628
SLC 421-E/R0490-XX-RFBC	490	608	672	708
SLC 421-E/R0570-XX-RFBC	570	688	752	788
SLC 421-E/R0650-XX-RFBC	650	768	832	868
SLC 421-E/R0730-XX-RFBC	730	848	912	948
SLC 421-E/R0810-XX-RFBC	810	928	992	1028
SLC 421-E/R0890-XX-RFBC	890	1008	1072	1108
SLC 421-E/R0970-XX-RFBC	970	1088	1152	1188
SLC 421-E/R1050-XX-RFBC	1050	1168	1232	1268
SLC 421-E/R1130-XX-RFBC	1130	1248	1312	1348
SLC 421-E/R1210-XX-RFBC	1210	1328	1392	1428
SLC 421-E/R1290-XX-RFBC	1290	1408	1472	1508
SLC 421-E/R1370-XX-RFBC	1370	1488	1552	1588
SLC 421-E/R1450-XX-RFBC	1450	1568	1632	1668
SLC 421-E/R1530-XX-RFBC	1530	1648	1712	1748
SLC 421-E/R1610-XX-RFBC	1610	1728	1792	1828
SLC 421-E/R1690-XX-RFBC	1690	1808	1872	1908
SLC 421-E/R1770-XX-RFBC	1770	1888	1952	1988

Status display of the outputs

The SLC 421 series is also available with a red/green status display integrated in the end plugs (facing the plug-in connection).

Ordering code:

SLC 421-E/Rxxxx-xx-RFBC-01

Fixing kit MS-1030

The fixing kit consists of 4 steel angles and 16 fixing screws.

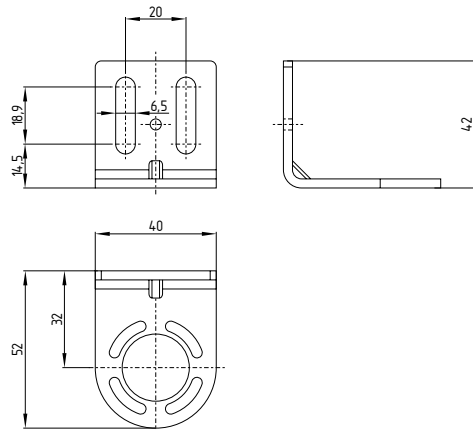

Centre fixing MS-1051 (optional accessory)

Mounting kit consists of 2 steel angles, 4 screws and 4 T-slot nuts for central fixing

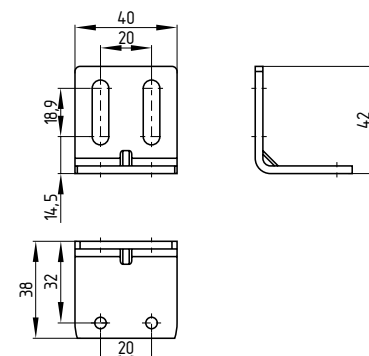

4. Electrical connection

4.1 Wiring example blanking

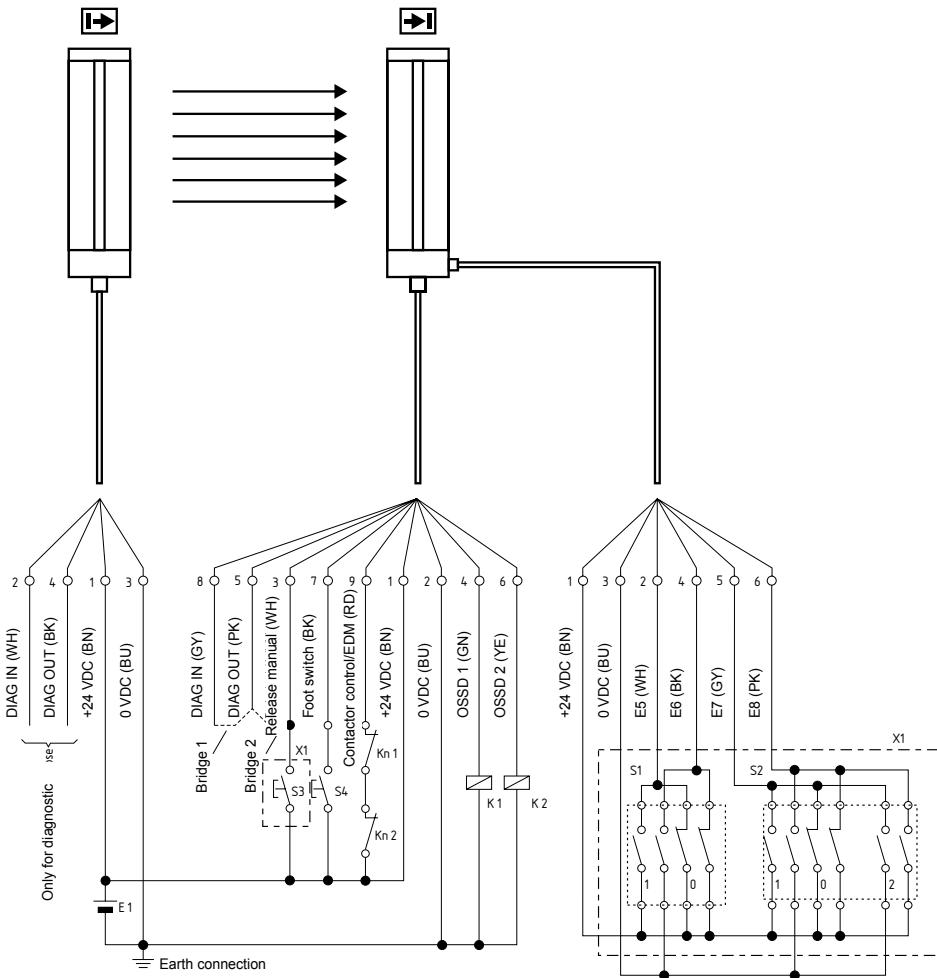

- Bridge 1:** Restart interlock active (manual reset)
(connect pin 8 and 5), wire S3
- Bridge 2:** Protective mode (auto reset) active
(connect pin 5 and 3), do not wire S3
- K1, K2:** Relay for processing the switching outputs OSSD 1, OSSD 2
- Kn1, Kn2:** Auxiliary contacts of the last switching relay (option), wiring only if EDM function active
- E1:** Power supply 24 V/DC ± 10%
- X1:** External control unit BDB 01 (includes S1, S2, S3)
- S1:** Command device key-operated selector switch 2-fold, 2 NO contacts / 2 NC contacts
- S2:** Command device selector switch 2-fold, 4 NO contacts / 2 NC contacts
- S3:** Restart interlock enabling button command device
- S4:** Command device foot switch

Restart interlock (manual reset) (bridge 1)

By bridging DIAG IN (pin 8) and DIAG OUT (pin 5), the restart interlock is activated.

Protective mode (bridge 2)

By bridging DIAG OUT (pin 5) and authorised operation (pin 3), the protective mode is activated.



To ensure correct functionality, an operating mode (restart interlock or protective mode) must be selected.



Upon delivery, the "contactor control" function is deactivated. Activating the function: refer to chapter 4.5.

4.2 Wiring example cyclic operation

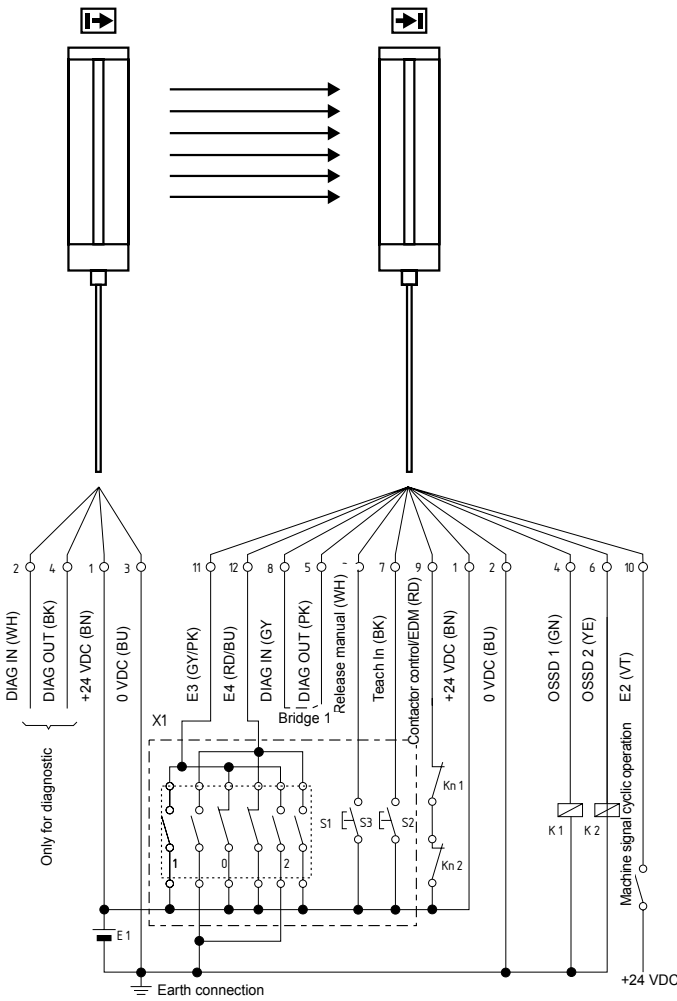

- Bridge 1:** Restart interlock active (manual reset)
(connect pin 8 and 5), wire S3
- K1, K2:** Relay for processing the switching outputs OSSD 1, OSSD 2
- Kn1, Kn2:** Auxiliary contacts of the last switching relay (option), wiring only if EDM active
- E1:** Power supply 24 V/DC \pm 10%
- X1:** External control unit BDT 01 (includes S1, S2, S3)
- S1:** Command device key-operated selector switch 2-fold, 4 NO contacts / 2 NC contacts
- S2:** Command device teach-in button
- S3:** Command device for restart

4.3 Wiring example BDB 01
(optional accessories)

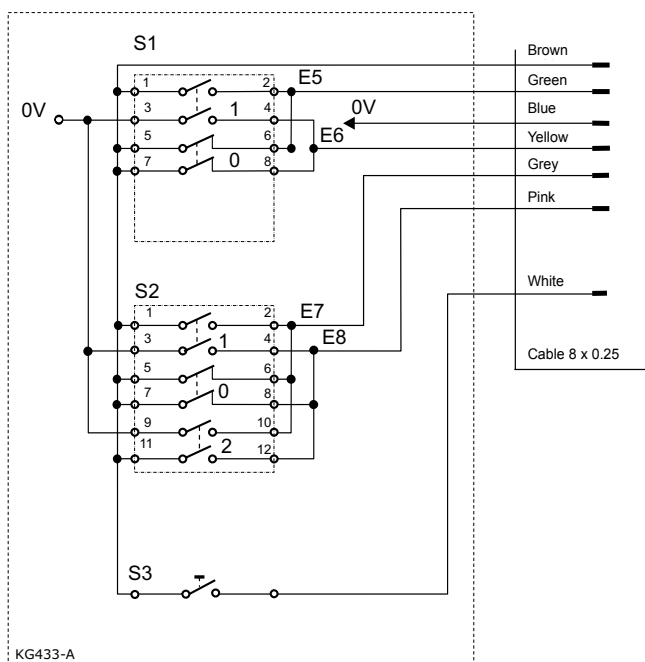

Contacts in idle state (S1, S2 position "0")

Signal name	M8 6-poles Pin Nr.
24 V	1
E5	2
0 V	3
E6	4
E7	5
E8	6
Signal name	M12 12-poles Pin Nr.
Restart interlock (manual reset)	3

4.4 Wiring example BDT 01
(optional accessories)

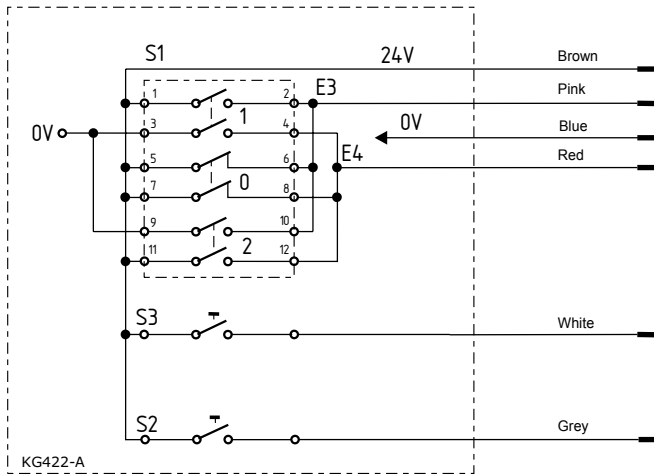

Contacts in idle state (S1 position "0")

Activation of the contactor control (EDM) without software

The contactor control can be activated without PC software as of firmware version 1.23 in diagnostic mode by means of cable bridges (refer to wiring diagram).

To activate the EDM function without PC software, proceed in the following way:

1. Establish the connections in accordance with the wiring diagram, see below, with two cable bridges



Both outputs OSSD1 and OSSD2 of the light curtain must be separated from the machine control.

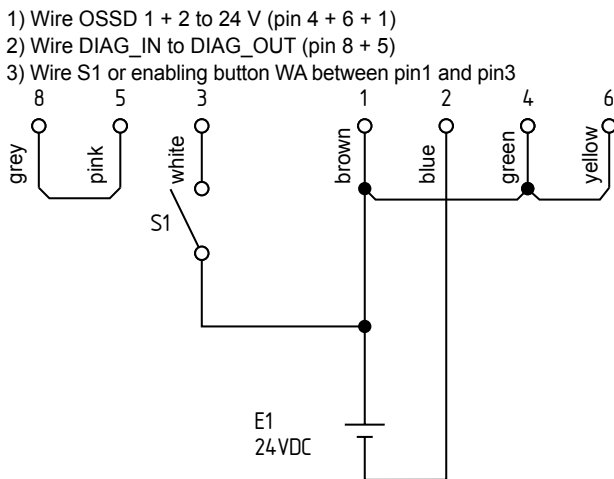

- 1) Wire OSSD 1 + 2 to 24 V (pin 4 + 6 + 1)
- 2) Wire DIAG_IN to DIAG_OUT (pin 8 + 5)
- 3) Wire S1 or enabling button WA between pin1 and pin3

Signal name	M12 12-poles Pin Nr.
24 V	1
E3	11
0 V	2
E4	12
Restart interlock (manual reset)	3
Teach-in	7

1. Execute the parameter assignment according to the following instructions:

1. Power ON
2. The light curtain detects faults and the EDM programming mode is activated.
3. Red LED flashes for 10 seconds at 2 Hz and blue LED shows during this period of time the current EDM state (supply state: OFF = EDM not active).
4. The EDM programming is realised, when at the same time three impulses are emitted by button S1 at 24V. Impulse duration ON time > 200 ms, OFF time > 200 ms
5. A successful EDM programming is confirmed by the green LED flashing three times (1Hz). During this time, the blue LED shows the new EDM state (ON = EDM active). After that, the OSSD fault mode of the light curtain is activated. The red LED flashes four times. If the EDM programming was not successful or timed out, the OSSD fault mode of the light curtain is immediately activated. The red LED flashes four times.
6. Power OFF
7. Remove cable bridges PIN 4 + 6 + 1 and if necessary cable bridge PIN 8 + 5
8. Wire OSSD 1 + 2 (pin 4 + 6)
9. Power ON

To reverse the EDM function, repeat the procedure step 2...7.

If the programming was not successful, the procedure can also be repeated.

The state of the EDM function is shown in diagnostic mode through the blue LED (ON = EDM active).



Both outputs OSSD1 and OSSD2 must be separated from the machine control. An EDM function, which is deactivated by means of the PC software, can not be activated in this way.

4.5 Connector configuration Receiver, Emitter & Cable

Connection Blanking

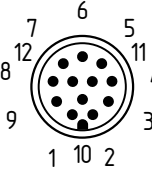
RECEIVER SLC: connector M12 / 12 pole	Signal Designation	Description
	1 BN	24 V DC Power supply
	2 BU	0 V DC Power supply
	3 WH	Restart interlock (manual reset) enabling button
	4 GR	OSSD 1 Safety output 1
	5 PK	Diagnostic OUT Output diagnostic data
	6 YE	OSSD 2 Safety output 2
	7 BK	E1 Input foot switch

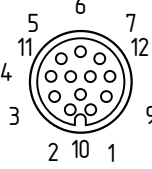
Cable: connector M12 / 12 pole	Signal Designation	Description
	8 GY	Diagnostic IN Input diagnostic data
	9 RD	Contactorm control EDM Input EDM
	10 VT	E2 not used
	11 GY/ PK	E3 not used
	12 RD/ BU	E4 not used

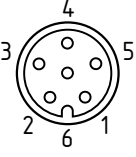
RECEIVER SLC: Connector M8 / 6 pole	Signal Designation	Description
	1 BN	24 VDC Power supply
	2 WH	E5 (Blanking) Input key-operated switch S1
	3 BU	0 VDC Power supply
	4 BK	E6 (Blanking) Input key-operated switch S1

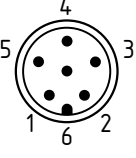
Cable: connector M8 / 6 pole	Signal Designation	Description
	5 GY	E7 (Blanking) Input selector switch S2
	6 PK	E8 (Blanking) Input selector switch S2

Connection Operation function

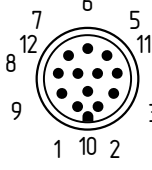
RECEIVER SLC: connector M12 / 12 pole	Signal Designation	Description
	1 BN	24 V DC Power supply
	2 BU	0 V DC Power supply
	3 WH	Restart interlock (manual reset) enabling button
	4 GR	OSSD 1 Safety output 1
	5 PK	Diagnostic OUT Output diagnostic data
	6 YE	OSSD 2 Safety output 2
	7 BK	Teach-in Input teach-in

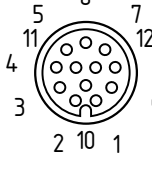
Cable: connector M12 / 12 pole	Signal Designation	Description
	8 GY	Diagnostic IN Input diagnostic data
	9 RD	Contactorm control EDM Input EDM
	10 VT	E2 Machine signal for cyclic operation
	11 GY/ PK	E3 Input key-operated switch
	12 RD/ BU	E4 Input key-operated switch

Connection Blanking and Operation function

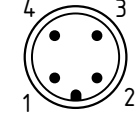
EMITTER SLC: connector M12 / 4 pole	Signal Designation	Description
	1 BN	24 VDC Power supply
	2 WH	Diagnostic IN Input diagnostic data
	3 BU	0 VDC Power supply
	4 BK	Diagnostic OUT Output diagnostic data

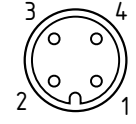
Cable: Connector M12 / 4 pole	Signal Designation	Description
	3	
	4	



The colour codes are only valid for the cable types mentioned below "optional accessories".

5. Set-up and maintenance

5.1 Check before start-up

Prior to start-up, the following items must be checked by the responsible person.

Wiring check prior to start-up

1. The voltage supply is a 24V direct current power supply, which meets the CE Directives, Low Voltage Directives. A power downtime of 20 ms must be bridged.
2. Presence of a voltage supply with correct polarity at the SLC.
3. The connecting cable of the transmitter is correctly connected to the transmitter and the connecting cable of the receiver correctly to the receiver.
4. The double insulation between the light curtain output and an external potential is guaranteed.
5. The outputs OSSD1 and OSSD2 are not connected to +24 VDC.
6. The connected switching elements (load) are not connected to +24 VDC.
7. If two or more SLC are used within close range compared to each other, an alternating arrangement must be observed. Any mutual interference of the systems must be prevented.

Switch the SLC on and check the operation in the following way:

The component performs a system test during approx. 2 seconds after the operating voltage has been switched on. After that, the outputs are enabled (if the protection field is not interrupted). The LED "OSSD ON" of the receiver is on.



In case of incorrect functionality, please follow the instructions listed in the chapter Fault diagnostic.

5.2 Maintenance



Do not use the SLC before the next inspection is terminated. An incorrect inspection can lead to serious and mortal injuries.

Conditions

For safety reasons, all inspection results must be archived. The operating principle of the SLC and the machine must be known in order to be able conducting an inspection. If the fitter, the planning technician and the operator are different persons, please make sure that the user has the necessary information at his disposal to be able conduct the maintenance.

5.3 Regular check

A regular visual inspection and functional test, including the following steps, is recommended:

1. The component does not have any visible damages.
2. The optics cover is not scratched or soiled.
3. Hazardous machinery parts can only be accessed by passing through the protection field of the SLC.
4. The staff remains within the detection area, when works are conducted on hazardous machinery parts.
5. The safety distance of the application exceed the mathematically calculated one.

Operate the machine and check whether the hazardous movement stops under the hereafter-mentioned circumstances.

6. Hazardous machine parts do not move when the protection field is interrupted.
7. The hazardous machine movement is immediately stopped, when the protection field is interrupted with the test rod immediately before the transmitter, immediately before the receiver and in the middle between the transmitter and the receiver.
8. No hazardous machine movement when the test rod is within the protection field.
9. The hazardous machine movement comes to standstill, when the voltage supply of the SLC is switched off.

5.4 Half-yearly inspection

The following items must be checked every six months or when a machine setting is changed.

1. Machine stops or does not inhibit any safety function.
2. No machine modification or connection change, which affects the safety system, has taken place.
3. The outputs of the SLC are correctly connected to the machine.
4. The total response time of the machine does not exceed the response time calculated during the first putting into operation.
5. The cables, the connectors, the caps and the mounting angles are in perfect condition.

5.5 Cleaning

If the optics cover of the sensors is extremely soiled, the OSSD outputs can be disabled. Clean with a soft cloth without exercising pressure. The use of aggressive, abrasive or scratching cleaning agents, which could attack the surface, is prohibited.

6. Diagnostic

6.1 LED status information

Receiver

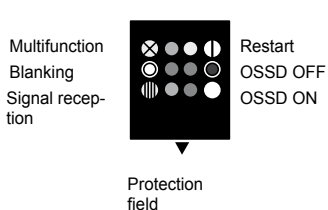

Function	LED colour
Multifunction	green
Blanking	blue
Signal reception	orange
Restart	yellow
OSSD OFF	red
OSSD ON	green

Description

Function display, beam coding
Protection field(s) inactive (blinking)
Safety-monitoring module of signal reception
Input for command device
Safety outputs signal condition OFF
Safety outputs signal condition ON

Transmitter

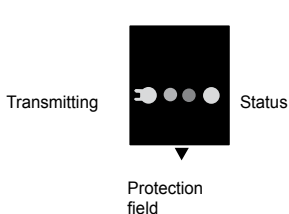

Function	LED colour
Transmitting Status	orange green

Description

Transmitter active
Function display, beam coding

Receiver		
LED	Status LED	Description
OSSD ON	ON	Protection field clear
	Flashing	Diagnostic mode active
OSSD OFF	ON	Protection field interrupted, system or configuration error
	Flashing	Diagnostic mode active, error output refer to Fault diagnostic table
Restart	ON	Start or restart interlock (manual reset) active, signal expected at output WA
Restart only for cyclic operation	ON (continuous signal)	Request actuation of the start button Request refer to start condition
	Flashing 2 Hz	Request for operator intervention
	flashing 0.25	Check machine contact
Signal reception	ON/flashing	Signal reception too low, check alignment and installation height between transmitter and receiver Cleaning the black profile cover
	OFF	Alignment between transmitter and receiver OK
Blanking	1 flashes	Fixed blanking of the protection field(s)
	2 flashes	Floating blanking, max. 1 beam
	3 flashes	Floating blanking, max. 2 light beams
	4 flashes	Floating (max. 1 beam) and fixed blanking of protection field(s)
	5 flashes	Floating (max. 2 beams) and fixed blanking of protection field(s)
Multifunction	Flashing	Beam coding A is active

Transmitter		
LED	Status LED	Description
Transmitting	ON	Standard operation, transmitter active
	Flashing	Configuration error
Status	Flashing	Beam coding A is active

6.2 Fault diagnostic

The light curtain performs an internal self-test after the operating voltage is switched on and the protection field is enabled. When a fault is detected, a corresponding flashing pattern is emitted at the receiver through the LED OSSD OFF (red). Every fault emission is followed by a one-second pause.

LED OSSD OFF	Fault feature	Action
OSSD OFF and LED restart continuous flashing	Wiring error for function selection (Restart interlock, automatic mode)	Check connection at the receiver, bridge 1 or bridge 2 must be wired (refer to Wiring)
1 flashes	Error at sensor receiver	Replace receiver
2 flashes	Error contactor control OFF	Check connections at contactor control input, refer to Wiring, check wiring of the auxiliary contacts
3 flashes	Error contactor control ON	Check wiring at contactor control input, short-circuit at +UB and mass. Power reset after fault rectification.
4 flashes	Errors at the OSSD outputs	Check the wiring of the outputs, OSSD for short-circuit at +UB and mass
5 flashes	Error configuration data	Check the configuration settings by means of the NSR-0801 BUS converter
6 flashes	Error blanking	The receiver has detected blanked beams as beams without interruption, i.e. locking. Check the configuration settings, repeat the teach process with blanking.

7. Disassembly and disposal

7.1 Disassembly

The safety switchgear must be disassembled in a de-energised condition only.

7.2 Disposal

The safety switchgear must be disposed of in an appropriate manner in accordance with the national prescriptions and legislations.

8. Appendix

8.1 Contact



Consultancy / Sales:

K.A. Schmersal GmbH
Industrielle Sicherheitssysteme
Mödinghofe 30
D-42279 Wuppertal
Tel.: +49 (0) 202 64 74 -0
Fax: +49 (0) 202 64 74- 100

You will also find detailed information regarding our product variety on our website: www.schmersal.com

Repair handling / shipping:
Safety Control GmbH
Am Industriepark 11
D-84453 Mühldorf/ Inn
Tel.: +49 (0) 8631-18796-0
Fax: +49 (0) 8631-18796-1

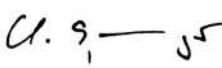
8.2 EC Declaration of conformity

EC Declaration of conformity		
Translation of the original declaration of conformity	Safety Control GmbH Am Industriepark 33 84453 Mühldorf / Inn Germany	
We hereby certify that the hereafter described safety components both in its basic design and construction conform to the applicable European Directives.		
Name of the safety component / type:	SLC 421	
Description of the safety component:	Safety light curtain	
Harmonised EC-Directives:	2006/42/EC EC-Machinery Directive 2004/108/EC EMC-Directive	
Applied standards:	EN 61496-1:2004 + A1 2008 CLC/TS 61496-2:2006 EN ISO 13849-1:2008; PL e EN 62061:2005; SIL 3	
Person authorised for the compilation of the technical documentation:	Ulrich Loss Möddinghofe 30 42279 Wuppertal	
Notified body for the prototype test:	TÜV Nord Cert GmbH Langemarckstr.20 45141 Essen ID n°: 0044	
EC-prototype test certificate:	n° 44 205 10 380009 000	
Place and date of issue:	Wuppertal, February 1, 2010	
		
SLC 421-A-DE Authorised signature Christian Spranger Managing Director	Authorised signature Klaus Schuster Managing Director	



The currently valid declaration of conformity can be downloaded from the internet at www.schmersal.net.



Safety Control GmbH
Am Industriepark 33
D-84453 Mühldorf / Inn

Telefon +49 - (0)86 31 - 187 - 9 60
Telefax +49 - (0)86 31 - 187 - 9 61
E-Mail: info@safetycontrol.com