



EN Operating instructions.pages 1 to 8
Translation of the original operating instructions

Content

1 About this document

1.1 Function 1

1.2 Target group: authorised qualified personnel. 1

1.3 Explanation of the symbols used 1

1.4 Appropriate use 1

1.5 General safety instructions 1

1.6 Warning about misuse 2

1.7 Exclusion of liability 2

2 Product description

2.1 Ordering code 2

2.2 Special versions. 2

2.3 Destination and use 2

2.4 Technical data 2

2.5 Safety classification 2

3 Mounting

3.1 General mounting instructions 3

3.2 Dimensions 3

3.3 First assembly 4

3.4 Maintenance and service 4

3.5 Adjustment. 5

4 Electrical connection

4.1 General information for electrical connection. 5

4.2 Contact variants 5

4.3 Connection. 5

4.4 Connector plug. 5

5 Set-up and maintenance

5.1 Functional testing. 6

5.2 Maintenance 6

6 Disassembly and disposal

6.1 Disassembly. 6

6.2 Disposal 6

7 Appendix

7.1 EC Declaration of conformity 7

1. About this document

1.1 Function

This operating instructions manual provides all the information you need for the mounting, set-up and commissioning to ensure the safe operation and disassembly of the safety switchgear. The operating instructions must be available in a legible condition and a complete version in the vicinity of the device.

1.2 Target group: authorised qualified personnel

All operations described in this operating instructions manual must be carried out by trained specialist personnel, authorised by the plant operator only.

Please make sure that you have read and understood these operating instructions and that you know all applicable legislations regarding occupational safety and accident prevention prior to installation and putting the component into operation.

The machine builder must carefully select the harmonised standards to be complied with as well as other technical specifications for the selection, mounting and integration of the components.

1.3 Explanation of the symbols used

 **Information, hint, note:**
This symbol is used for identifying useful additional information.

 **Caution:** Failure to comply with this warning notice could lead to failures or malfunctions.
Warning: Failure to comply with this warning notice could lead to physical injury and/or damage to the machine.

1.4 Appropriate use

The products described in these operating instructions are developed to execute safety-related functions as part of an entire plant or machine. It is the responsibility of the manufacturer of a machine or plant to ensure the correct functionality of the entire machine or plant.

The safety switchgear must be exclusively used in accordance with the versions listed below or for the applications authorised by the manufacturer. Detailed information regarding the range of applications can be found in the chapter "Product description".

1.5 General safety instructions

The user must observe the safety instructions in this operating instructions manual, the country-specific installation standards as well as all prevailing safety regulations and accident prevention rules.

 Further technical information can be found in the Schmersal catalogues or in the online catalogue on the Internet: www.schmersal.net.

The information contained in this operating instructions manual is provided without liability and is subject to technical modifications.

There are no residual risks, provided that the safety instructions as well as the instructions regarding mounting, commissioning, operation and maintenance are observed.

1.6 Warning about misuse



In case of improper use or manipulation of the safety switch-gear, personal hazards or damages to machinery or plant components cannot be excluded when safety switchgear is used. The relevant requirements of the standard ISO 14119 must be observed.

1.7 Exclusion of liability

We shall accept no liability for damages and malfunctions resulting from defective mounting or failure to comply with this operating instructions manual. The manufacturer shall accept no liability for damages resulting from the use of unauthorised spare parts or accessories.

For safety reasons, invasive work on the device as well as arbitrary repairs, conversions and modifications to the device are strictly forbidden; the manufacturer shall accept no liability for damages resulting from such invasive work, arbitrary repairs, conversions and/or modifications to the device.

2. Product description

2.1 Ordering code

This operating instructions manual applies to the following types:

BNS-B20-①Z②-③-④

No.	Option	Description
①	11	1 NO contacts / 1 NC contacts
	12	1 NO contacts / 2 NC contacts
	02	2 NC contacts
②	G	Without LED
		With LED
③		Connecting cable bottom
	H	Connecting cable back
	ST	M12 connector bottom
④	L	For left hinged doors
	R	For right hinged doors

2.2 Special versions

For special versions, which are not listed in the order code below 2.1, these specifications apply accordingly, provided that they correspond to the standard version.

2.3 Destination and use

The BNS-B20 safety sensor is designed for application in safety circuits and is used for monitoring the position of movable safety guards to ISO 14119 and IEC 60947-5-3. To actuate the safety sensors, only the BNS-B20-B01 actuator can be used, conventional magnets are not suitable.

The safety sensors are used for applications, in which the hazardous situation is terminated without delay when the safety guard is opened.



The safety switchgears are classified according to ISO 14119 as type 4 switching devices.

The entire system consisting of the BNS-B20 safety door handle switch and the safety-monitoring module (AES, SRB) meets the requirements of the standard IEC 60947-5-3.



The user must evaluate and design the safety chain in accordance with the relevant standards and the required safety level.



The entire concept of the control system, in which the safety component is integrated, must be validated to the relevant standards.

2.4 Technical data

Standards:	IEC 60947-5-3, BG-GS-ET-14
Enclosure:	glass-fibre reinforced thermoplastic
Protection class:	IP67 to IEC 60529
Termination:	LIYY cable or M12 connector
Connecting cable:	4 x 0.25 mm ² with signalling contact: 6 x 0.25 mm ²
Integrated connector:	M8 x 1, 4-pole with signalling contact: M8 x 1, 8-pole
Operating principle:	magnetic
Actuator:	BNS-B20-B01
Coding level according to ISO 14119:	low
Switching distances:	
- Assured switching distance s_{ao} :	0 mm
- Assured switch-off distance s_{af} :	22 mm
Switching condition indication:	LED only with ordering suffix G
Rated insulation voltage U_i :	32 V
Rated impulse withstand voltage U_{imp} :	0.8 kV
Switching voltage:	with connector: max. 24 VDC with connector and LED: max. 24 VDC with cable: max. 110 VAC/DC with cable and LED: max. 24 VDC
Switching current:	without LED: max. 250 mA with LED: max. 10 mA
Switching capacity:	without LED: max. 3 W with LED: max. 240 mW
Required short-circuit current:	100 A
Ambient temperature:	-25 °C ... +70 °C
Storage and transport temperature:	-25 °C ... +70 °C
Max. switching frequency:	5 Hz
Resistance to shock:	30 g / 11 ms
Resistance to vibration:	10 ... 55 Hz, amplitude 1 mm
Max. door weight:	Hinged guard: 5 kg; sliding guard: 3 kg

2.5 Safety classification

Standards:	ISO 13849-1
Safety contact:	
- NC / NC combination:	S11-S12 and S21-S22
- NC / NO combination:	S21-S22 and S13-S14
Intended structure:	
- 2-channel usage:	usable to cat. 4 / PL e with suitable logic unit
B_{10d} NC contacts at 20 % contact load:	25.000.000
B_{10d} NO contacts at 20 % contact load:	25.000.000
Service life:	20 years

$$MTTF_d = \frac{B_{10d}}{0,1 \times n_{op}} \quad n_{op} = \frac{d_{op} \times h_{op} \times 3600 \text{ s/h}}{t_{cycle}}$$

(Determined values can vary depending on the application-specific parameters h_{op} , d_{op} and t_{cycle} as well as the load.)

If multiple safety components are wired in series, the Performance Level to ISO 13849-1 will be reduced due to the restricted error detection under certain circumstances.

3. Mounting

3.1 General mounting instructions



During fitting, the requirements of ISO 14119 must be observed.

- The BNS-B20 door-handle switch is only suitable for use on smaller low-weight safety guards, max. door weights: hinged door: 5 kg; sliding door: 3 kg.
- Fitting is only authorised in a de-energised condition
- Any mounting position, provided that the active surfaces are opposite
- Exclusively mount the sensor on flat surfaces to avoid tensile stresses that could damage the sensor or lead to varying switching distances
- Do not install the safety sensor and the actuator in strong magnetic fields
- If possible, do not mount the sensor and the actuator on ferromagnetic material. The use of a non-magnetic spacer of at least 5 mm thick must be used. The use of non-magnetic fixing screws is recommended also.
- Do not subject the safety sensor and actuator to extreme vibrations and shocks.
- Keep away from metal chips.
- The mounting distance between two sensors should always be at least 50 mm



Safety sensor and actuator must be permanently fitted to the safety guards and protected against displacement by suitable measures (tamperproof screws, gluing, drilling of the screw heads).



The required M5 hexagonal screws and washers for the fixation are not included in delivery.

3.2 Dimensions

All measurements in mm.

Sensor with connector, right hinged door

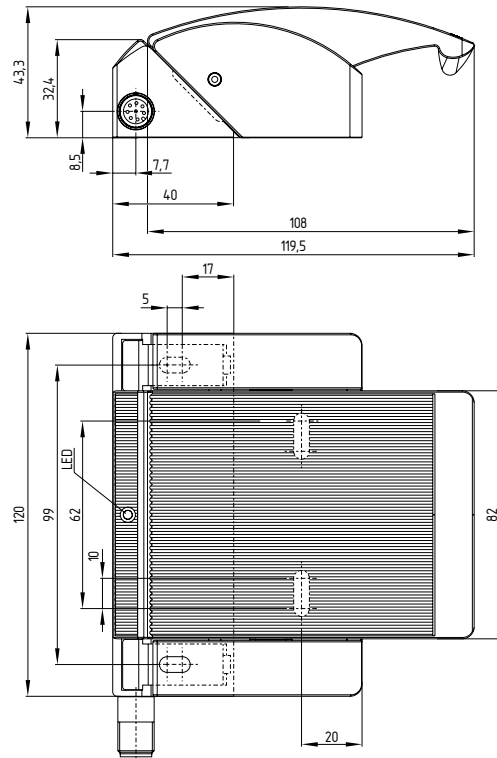

Sensor with cable at the back

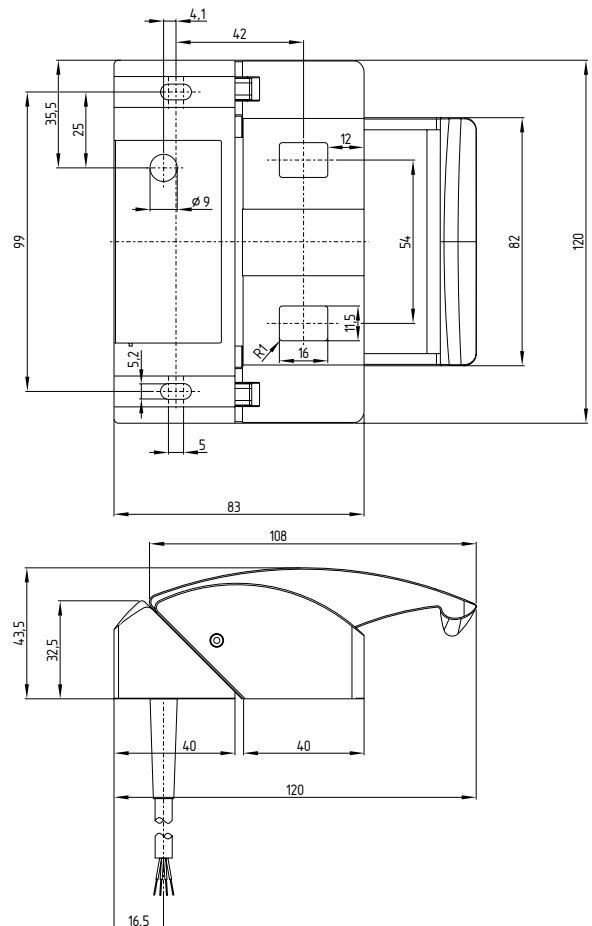

3.3 First assembly

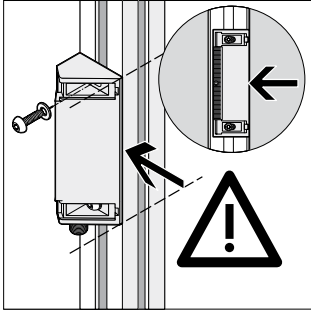

Step 1
Drill according to the drill pattern:
4 x M5 (if necessary) and screw the
sensor unit tightly to the door frame
using hexagonal screws DIN912-M5
(min. length 16 mm)

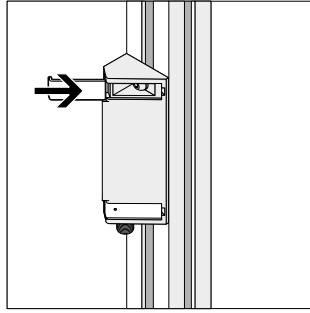

Step 2
Slide and latch the plates
(screw cover) of the sensor
in the hole

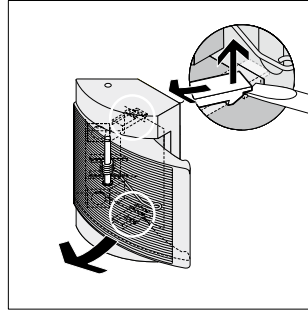

Step 3
Remove the spring from the handle.
Use screwdriver to remove the
handle

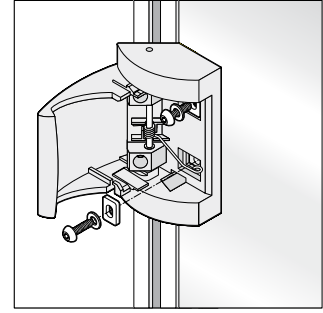

Step 4
Loosely tighten the handle unit
by means of hexagonal screws
DIN912-M5, so that it can be
aligned afterwards.

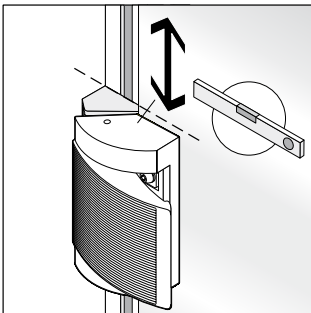

Step 5
Align the handle unit with the
sensor unit (top of sensor unit
and handle unit at the same
height)

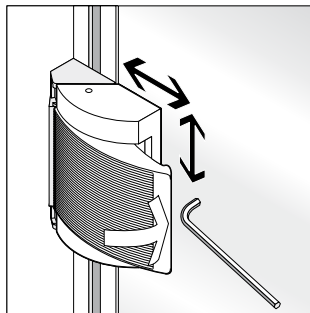

Step 6
Press down the handle, so that
it latches. Accurately align the
handle unit with the sensor.
Tighten the handle unit using the
supplied hexagonal key.

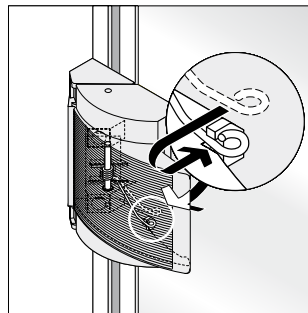

Step 7
Put back the spring in the
handle unit

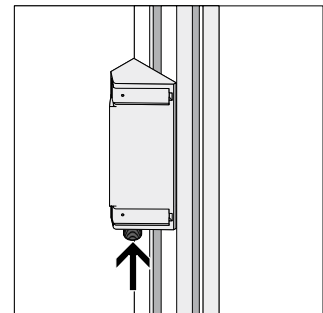

Step 8
Connect to the AES safety-
monitoring module (connector)

3.4 Maintenance and service

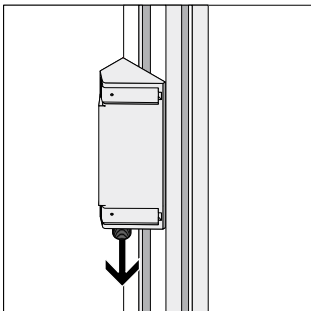

Step 1
Unplug the connector

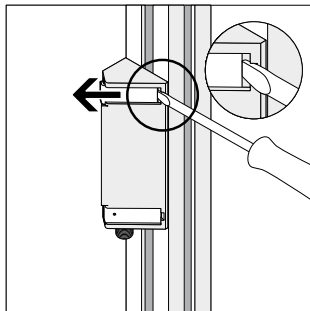

Step 2
Remove the plates of the sensor
using a screwdriver, unscrew
the device (if necessary)

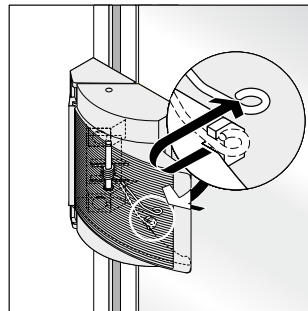

Step 3
Remove the spring from the
handle.

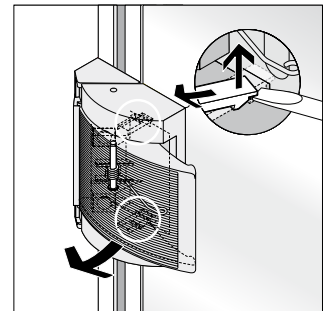

Step 4
Remove the handle using a
screwdriver, unscrew the device
(if necessary) Procedure for
fixing: refer to first assembly

3.5 Adjustment

The LED of the BNS-B20 variants can only be used as a rough setting tool. The correct functionality of both safety channels must be checked by means of the connected safety-monitoring module.



Recommended Adjustment

Align the safety sensor and actuator at a distance of $0.5 \times s_{ao}$.

4. Electrical connection

4.1 General information for electrical connection



The electrical connection may only be carried out by authorised personnel in a de-energised condition.

The safety sensors must be wired in accordance with the wire colours or the pin configuration.

4.2 Contact variants

The contact position shows the actuated sensor function when the safety guard is closed. For safety sensors with LED, the LED is illuminated when the safety guard is closed.

Safety contacts: S21-S22 and S11-S12 or S13-S14

Signalling contact: S31-S32

The numbers between brackets indicate the PIN configuration of the versions with integrated connector; indication of the wire colours for the version with cable.

BNS-B20-11Z

(3) BK S13 → S14 BU (4)
(1) WH S21 → S22 BN (2)

BNS-B20-11ZG

(3) BK S13 → S14 BU (4)
(1) WH S21 → S22 BN (2)

BNS-B20-12Z

(3) GY S13 → S14 PK (4)
(1) GN S21 → S22 YE (2)
(5) WH S31 → S32 BN (6)

BNS-B20-12ZG

(3) GY S13 → S14 PK (4)
(1) GN S21 → S22 YE (2)
(5) WH S31 → S32 BN (6)

BNS-B20-02Z

(3) BK S11 → S12 BU (4)
(1) WH S21 → S22 BN (2)

BNS-B20-02ZG

(3) BK S11 → S12 BU (4)
(1) WH S21 → S22 BN (2)

4.3 Connection

The BNS-B20-12z(G) can be used on safety-monitoring modules with NO/NC inputs or on safety-monitoring modules with two NC inputs, at the user's discretion. Depending on the type of safety-monitoring module, the sensors must be wired as shown below. Depending on the chosen safety-relevant contacts, an additional NC or NO contact is available for signalling purposes. For safety sensors with LED, the LED is located in S21 – S22 and the LED will be on when the safety guard is closed.

Connection to safety-monitoring modules with NO/NC input

NO: S13 - S14 to the NO input of the safety-monitoring module (AES safety-monitoring module: terminal S13 - S14)

NC: S21 - S22 to the NC input of the safety-monitoring module (AES safety-monitoring module: terminal S21 - S22)

NC: S31 - S32 can be used as a signalling contact

Connection to safety-monitoring modules with NC/NC input

NC: S21 - S22 to the 1st NC input of the safety-monitoring module (AES safety-monitoring module: terminal S21 - S22)

NC: S31 - S32 to the 2nd NC input of the safety-monitoring module (AES safety-monitoring module: terminal S11 - S12)

NO: S13 - S14 can be used as a signalling contact

Depending on the termination of the safety sensor, the coding is ensured in this way.

Inductive loads (e.g. contactors, relays, etc.) are to be suppressed by means of a suitable circuit.



Information for the selection of suitable safety-monitoring modules can be found in the Schmersal catalogues or in the online catalogue on our website: www.schmersal.net.

Connecting multiple BNS-B20 safety sensors to one AES safety-monitoring module is technically possible. To connect multiple safety sensors (check if authorised!), their NO contacts are wired in parallel and their NC contacts in series. The Protect-IE-11 or -02 or PROTECT-PE-11(-AN) or -02 input expander module can be used to connect up to 4 safety sensors with NC/NC or NC/NO contacts.

BNS-B20 safety sensors equipped with LED's should not be wired in series, except with the Protect-IE input expander module. As a result of this, the luminosity of the LED's would considerably decrease and the voltage could drop below the minimum input voltage of the downstream safety-monitoring module.

4.4 Connector plug

Integrated connector M12, 8-pole

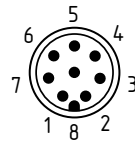

M12, 4-pole

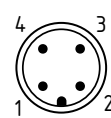

5. Set-up and maintenance

5.1 Functional testing

The safety function of the safety sensor must be tested. The following conditions must be previously checked and met:

1. Fitting of the sensor and the actuator
2. Fitting and integrity of the power cable
3. The system is free of dirt and soiling
(in particular metal chips)

5.2 Maintenance

In the case of correct installation and adequate use, the safety sensor features maintenance-free functionality.

A regular visual inspection and functional test, including the following steps, is recommended:

- Check the fitting of the sensor and the actuator
- Remove possible metal chips
- Check the cable for damage.



Adequate measures must be taken to ensure protection against tampering either to prevent tampering of the safety guard, for instance by means of replacement actuators.

Damaged or defective components must be replaced.

6. Disassembly and disposal

6.1 Disassembly

The safety switchgear must be disassembled in a de-energised condition only.

6.2 Disposal

The safety switchgear must be disposed of in an appropriate manner in accordance with the national prescriptions and legislations.

7. Appendix

7.1 EC Declaration of conformity

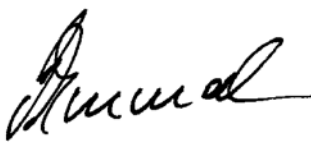
	
<h3>EC Declaration of conformity</h3>	
Translation of the original Declaration of Conformity	K.A. Schmersal GmbH & Co. KG Mödinghofe 30 42279 Wuppertal Germany Internet: www.schmersal.com
<p>We hereby certify that the hereafter described safety components both in its basic design and construction conform to the applicable European Directives.</p>	
Name of the safety component / type:	BNS-B20
Description of the safety component:	Coded safety-sensor with magnetic operating principle in combination with the AES / AZR / SRB safety-monitoring modules from Schmersal or an equivalent safety-oriented control system fulfilling the requirements of the IEC 60947-5-3.
Harmonised EC-Directives:	2006/42/EC-EC-Machinery Directive
Person authorised for the compilation of the technical documentation:	Oliver Wacker Mödinghofe 30 42279 Wuppertal
Place and date of issue:	Wuppertal, 11 November 2015
BNS-B20-C-EN	
	Authorised signature Philip Schmersal Managing Director



The currently valid declaration of conformity can be downloaded from the internet at www.schmersal.net.



K. A. Schmersal GmbH & Co. KG
Möddinghofe 30, D - 42279 Wuppertal
Postfach 24 02 63, D - 42232 Wuppertal

Phone: +49 - (0)2 02 - 64 74 - 0
Telefax: +49 - (0)2 02 - 64 74 - 1 00
E-Mail: info@schmersal.com
Internet: <http://www.schmersal.com>