



EN Operating instructions. pages 1 to 6
Translation of the original operating instructions

Content

1 About this document

1.1 Function 1

1.2 Target group: authorised qualified personnel. 1

1.3 Explanation of the symbols used 1

1.4 Appropriate use 1

1.5 General safety instructions 1

1.6 Warning about misuse 2

1.7 Exclusion of liability 2

2 Product description

2.1 Ordering code 2

2.2 Special versions. 2

2.3 Destination and use 2

2.4 Technical data 2

2.5 Safety classification 2

3 Mounting

3.1 General mounting instructions 3

3.2 Dimensions 3

3.3 Axial misalignment. 3

3.4 Adjustment. 3

4 Electrical connection

4.1 General information for electrical connection. 4

4.2 Contact variants. 4

4.3 Connection. 4

5 Set-up and maintenance

5.1 Functional testing. 4

5.2 Maintenance 4

6 Disassembly and disposal

6.1 Disassembly. 4

6.2 Disposal 4

7 Appendix

7.1 EC Declaration of conformity 5

1. About this document

1.1 Function

This operating instructions manual provides all the information you need for the mounting, set-up and commissioning to ensure the safe operation and disassembly of the safety switchgear. The operating instructions must be available in a legible condition and a complete version in the vicinity of the device.

1.2 Target group: authorised qualified personnel

All operations described in this operating instructions manual must be carried out by trained specialist personnel, authorised by the plant operator only.

Please make sure that you have read and understood these operating instructions and that you know all applicable legislations regarding occupational safety and accident prevention prior to installation and putting the component into operation.

The machine builder must carefully select the harmonised standards to be complied with as well as other technical specifications for the selection, mounting and integration of the components.

1.3 Explanation of the symbols used

 **Information, hint, note:**
This symbol is used for identifying useful additional information.

 **Caution:** Failure to comply with this warning notice could lead to failures or malfunctions.
Warning: Failure to comply with this warning notice could lead to physical injury and/or damage to the machine.

1.4 Appropriate use

The products described in these operating instructions are developed to execute safety-related functions as part of an entire plant or machine. It is the responsibility of the manufacturer of a machine or plant to ensure the correct functionality of the entire machinery or plant.

The safety switchgear must be exclusively used in accordance with the versions listed below or for the applications authorised by the manufacturer. Detailed information regarding the range of applications can be found in the chapter "Product description".

1.5 General safety instructions

The user must observe the safety instructions in this operating instructions manual, the country-specific installation standards as well as all prevailing safety regulations and accident prevention rules.

 Further technical information can be found in the Schmersal catalogues or in the online catalogue on the Internet: www.schmersal.net.

The information contained in this operating instructions manual is provided without liability and is subject to technical modifications.

There are no residual risks, provided that the safety instructions as well as the instructions regarding mounting, commissioning, operation and maintenance are observed.

1.6 Warning about misuse



In case of improper use or manipulation of the safety switch-gear, personal hazards or damages to machinery or plant components cannot be excluded. The relevant requirements of the standard EN ISO 14119 must be observed.

1.7 Exclusion of liability

We shall accept no liability for damages and malfunctions resulting from defective mounting or failure to comply with this operating instructions manual. The manufacturer shall accept no liability for damages resulting from the use of unauthorised spare parts or accessories.

For safety reasons, invasive work on the device as well as arbitrary repairs, conversions and modifications to the device are strictly forbidden; the manufacturer shall accept no liability for damages resulting from such invasive work, arbitrary repairs, conversions and/or modifications to the device.

2. Product description

2.1 Ordering code

This operating instructions manual applies to the following types:

EX-BNS 33-①Z②-2187-3G/D

No.	Option	Description
①	12	1 NO contact / 2 NC contacts
	02	2 NC contacts
②		without LED
	G	with LED

2.2 Special versions

For special versions, which are not listed in the order code below 2.1, these specifications apply accordingly, provided that they correspond to the standard version.

2.3 Destination and use

The safety sensor can be used for monitoring the position of movable guards and flaps in explosion-endangered areas of Zone 2 and 22 category 3GD. The installation and maintenance requirements to the standard series EN 60079 must be met. For the actuation of the safety sensors, only the EX-BPS 33 actuator can be used.

The safety switches are used for applications, in which the hazardous situation is terminated without delay when the safety guard is opened.

Only the entire system consisting of the safety sensor (EX-BNS), the actuator (EX-BPS) and the safety-monitoring module (AES/SRB/AZR) meet the requirements of the standard EN 60947-5-3.

Conditions for safe operation

Due to their specific impact energy, the components must be fitted with a protection against mechanical stresses.

The specific ambient temperature range must be observed. The user must provide for a protection against the permanent influence of UV rays. The energy restriction for LED versions (24 V/10 mA) must be ensured by the user.



The user must evaluate and design the safety chain in accordance with the relevant standards and the required safety level.



The entire concept of the control system, in which the safety component is integrated, must be validated to the relevant standards.

2.4 Technical data

Equipment category:	⊕ II 3GD
Ex protection:	Ex nC IIC T6 Gc X; Ex tc IIIC T80°C Dc X
- EX-BNS 33:	c 80°C
- EX-BPS 33:	
Standards:	EN 60947-5-3, EN 60079-0, EN 60079-15, EN 60079-31, EN 13463-1, EN 13463-5, BG-GS-ET-14
Design:	rectangular
Enclosure:	glass-fibre reinforced thermoplastic
Max. impact energy:	1 J
Protection class:	IP67 to EN 60529
Connection:	Boflex cable
Cable section:	6 x 0.25 mm ²
Operating principle:	magnetic
Actuating magnet:	EX-BPS-33, coded
assured switching distance s_{so} :	5 mm
assured switch-off distance s_{sr} :	15 mm
Switching condition indication:	LED only with ordering suffix G
Switching voltage max.:	100 VAC / DC with LED: 24 VDC
Switching current max.:	250 mA with LED: 10 mA
Switching capacity max.:	,3 W with LED: 240 mW
Ambient temperature:	-25 °C ... +70 °C
Storage and transport temperature:	-25 °C ... +70 °C
Repeat accuracy R:	≤ 0.1 x s_{ao}
Max. switching frequency:	ca. 5 Hz
Resistance to shock:	30 g / 11 ms
Resistance to vibration:	10 ... 55 Hz, amplitude 1 mm

2.5 Safety classification

Standards:	EN ISO 13849-1
B_{10d} (NC/NO contact):	25,000,000 at max. 20 % contact load
Service life:	20 years

$$MTTF_d = \frac{B_{10d}}{0,1 \times n_{op}} \quad n_{op} = \frac{d_{op} \times h_{op} \times 3600 \text{ s/h}}{t_{cycle}}$$

(Specifications can vary depending on the application-specific parameters h_{op} , d_{op} and t_{cycle} as well as the load.)

An individual switch can be used in a category 3 or 4 architecture up to PL e.

If multiple safety components are wired in series, the Performance Level to EN ISO 13849-1 will be reduced due to the restricted error detection under certain circumstances.

3. Mounting

3.1 General mounting instructions

- Fitting is only authorised in a de-energised condition
- Do not use the sensor and the actuator as a mechanical backstop
- Any mounting position, provided that the active surfaces are opposite
- Inseparably fix the safety sensor and the actuator to the safety guard
- Ensure the safety sensor is mounted on a flat surfaces to avoid tensile stresses that could damage the sensor or lead to varying switching distances
- Do not install the safety sensor and the actuator in strong magnetic fields
- If possible, do not mount the sensor and the actuator on ferromagnetic material. Otherwise, the following variations of the switching distances may be expected: A distance of 0...5 mm from the mounting surface to the ferromagnetic material: switching distance is only approx. 40 % of the original switching distance; A distance of 5...8 mm: approx. 80 % of the original switching distance; > 10 mm: no change (use spacer BN 31/33). The use of non-magnetic fixing screws is recommended also.
- Do not subject the safety sensor and actuator to extreme vibrations and shocks.
- Keep away from metal chips
- The mounting distance between two sensors should always be at least 50 mm



Please observe the specifications for the maximum impact energy in the technical data.

3.2 Dimensions

All measurements in mm.

Safety sensor with cable

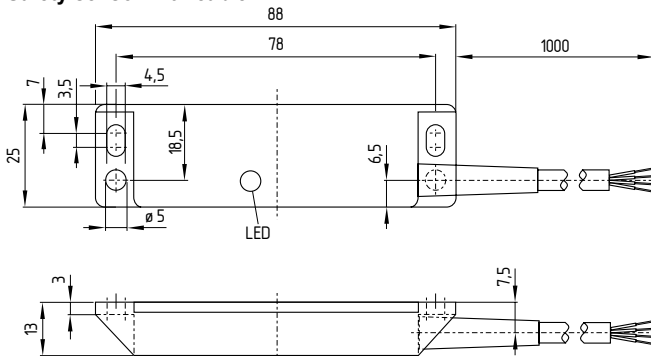

Actuator

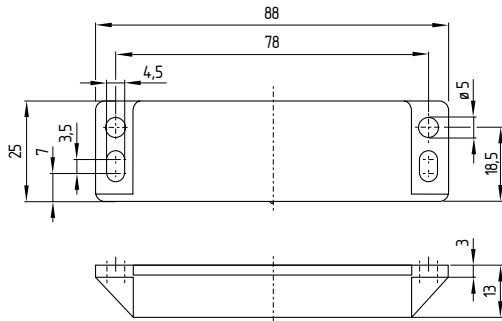

Spacer

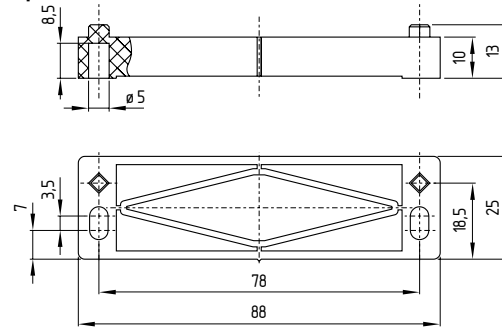

3.3 Axial misalignment

A horizontal and vertical misalignment of the safety sensor and the actuator is tolerated. The possible misalignment depends on the distance of the active surfaces of the sensor and the actuator. The sensor remains active within the tolerance range.

The specified switching distances refer to oppositely mounted safety sensors and actuators. Different arrangements are possible, however this may lead to different switching distances.

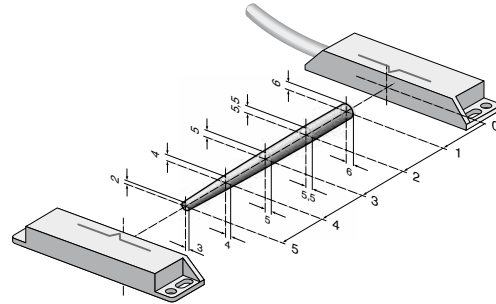

Assured switching distance: $s_{ao} = 5 \text{ mm}$
Assured switch-off distance: $s_{ar} = 15 \text{ mm}$

3.4 Adjustment

If the central marking of the actuator is within the represented base position area, a release signal is given at the connected safety-monitoring module.

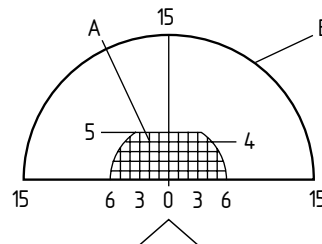

Key

- A = Base position area (sensor actuated, release)
- B = Switch-off area (at the latest point, all Reed contacts are not actuated)

The LED can only be used as rough setting tool. The correct functionality of both safety channels must be checked by means of the connected safety-monitoring module.

4. Electrical connection

4.1 General information for electrical connection



The electrical connection may only be carried out by authorised personnel in a de-energised condition.

The safety sensors must be wired in accordance with the wire colours or the pin configuration.

4.2 Contact variants

The contact position shows the actuated sensor function when the safety guard is closed. If the safety sensor is equipped with a LED, the LED will be illuminated when the guard is open.

Safety contacts: 02Z: S11-S12 and S21-S22

12Z: S21-S22 and S31-S32

Signalling contact: 12Z: S13-S14

EX-BNS 33-12Z(G)-2187-3G/D

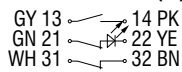

EX-BNS 33-02Z(G)-2187-3G/D

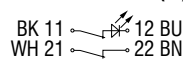

4.3 Connection

For safety-monitoring modules with two NC inputs, the wires of the EX-BNS 33-12Z-2187-3G/D safety sensor must be wired as follows:

NC contacts: WH (21) und BN (22) at the "NC input" of the safety-monitoring module

NC contacts: GN (31) und YE (32) at the "NC input" of the safety-monitoring module

NO contacts: GY (13) und PK (14) can be used for signalling purposes.



Information for the selection of suitable safety-monitoring modules can be found in the Schmersal catalogues or in the online catalogue on the Internet: www.schmersal.net.

Connecting multiple safety sensors to one suitable safety-monitoring module is technically possible. To connect multiple safety sensors (check if authorised!), their NO contacts are wired in parallel and their NC contacts in series. The Protect-IE-11 or PROTECT-PE-11 (-AN) input expander module can be used to connect up to 4 safety sensors with NC/NO contacts.

When connecting the EX-BNS-33-12Z-2187-3G/D safety sensors to the AES 1102/1112/7112 safety-monitoring module, the connecting cables of the S14/S22/S32 of the EX-BNS must be wired to the terminals with the same label of the AES. The S13/S21/S31 connecting cables must be wired together to the C terminal of the AES (refer to AES operating instructions manual).

Connecting more than two magnetic safety sensors EX-BNS 33-12Z-2187-3G/D to the safety monitoring modules AES 1102/1112/7112 is not possible.

If safety sensors with LED's are used, the light intensity of the LED's will decrease as the number of open safety guards increases. Safety sensors equipped with LED's shall not be wired in series, except for the Protect-IE input expander module. As a result of this, the luminosity of the LED's would considerably decrease and the voltage could drop below the minimum input voltage of the downstream safety-monitoring module.

In case of series-wiring at SRB max. 1 sensor with LED indication for U_N .

Inductive loads (e.g. contactors, relays, etc.) are to be suppressed by means of a suitable circuit. If the EX-BNS 33 with LED is used in conjunction with an inappropriate AES safety-monitoring module, the energy restriction for LED versions (24 V/10 mA) must be ensured by the user.

5. Set-up and maintenance

5.1 Functional testing

The safety function of the safety components must be tested. The following conditions must be previously checked and met:

1. The installation is executed according to the instructions
2. The connection is executed correctly
3. The safety component is not damaged
4. The system is free of dirt and soiling (in particular metal chips)
5. Check cable entry and connections in a de-energised condition

5.2 Maintenance

In the case of correct installation and adequate use, the safety sensor features maintenance-free functionality. A regular visual inspection and functional test, including the following steps, is recommended:

- Check the fitting of the sensor and the actuator
- Remove possible metal chips
- Check the cable for damage.

Damaged or defective components must be replaced.

6. Disassembly and disposal

6.1 Disassembly

The safety switchgear must be disassembled in a de-energised condition only.

6.2 Disposal

The safety switchgear must be disposed of in an appropriate manner in accordance with the national prescriptions and legislations.

7. Appendix

7.1 EC Declaration of conformity

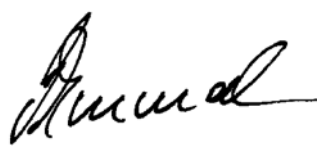
	
<h2>EC Declaration of conformity</h2>	
Translation of the original Declaration of Conformity	K. A. Schmersal GmbH & Co. KG Möddinghofe 30 42279 Wuppertal Germany Internet: www.schmersal.com
We hereby certify that the hereafter described safety components both in its basic design and construction conform to the applicable European Directives.	
Name of the safety component:	EX-BNS 33-...-2187-3G/D Ⓢ II 3G Ex nC IIC T6 Gc X Ⓢ II 3D Ex tc IIIC T80°C Dc X
Description of the safety component:	Coded safety sensor with magnetic operating principle in combination with the AES and SRB safety-monitoring modules from Schmersal
Relevant EC-Directives:	2006/42/EC EC-Machinery Directive 94/9/EC EC-Explosion Protection Directive (ATEX)
Person authorized for the compilation of the technical documentation:	Oliver Wacker Möddinghofe 30 42279 Wuppertal
Place and date of issue:	Wuppertal, October 6, 2014
EX-BNS33-2187-D-EN	
	Authorised signature Philip Schmersal Managing Director



The currently valid declaration of conformity can be downloaded from the internet at www.schmersal.net.



K. A. Schmersal GmbH & Co. KG
Möddinghofe 30, D - 42279 Wuppertal
Postfach 24 02 63, D - 42232 Wuppertal

Phone: +49 - (0)2 02 - 64 74 - 0
Telefax: +49 - (0)2 02 - 64 74 - 1 00
E-Mail: info@schmersal.com
Internet: <http://www.schmersal.com>