



EN Operating instructions. pages 1 to 10
Translation of the original operating instructions

Content

1 About this document

1.1 Function 1

1.2 Target group: authorised qualified personnel. 1

1.3 Explanation of the symbols used 1

1.4 Appropriate use 1

1.5 General safety instructions 1

1.6 Warning about misuse 2

1.7 Exclusion of liability 2

2 Product description

2.1 Ordering code 2

2.2 Special versions. 2

2.3 Destination and use 2

2.4 Technical data 2

2.5 Safety classification 3

3 Mounting

3.1 General mounting instructions 3

3.2 Adjustment and inspection of the switching angle. 4

3.3 Dimensions 4

4 Electrical connection

4.1 General information for electrical connection. 5

4.2 Contact variants. 5

4.3 Switch travel. 5

5 Set-up and maintenance

5.1 Functional testing. 6

5.2 Maintenance 6

6 Disassembly and disposal

6.1 Disassembly. 6

6.2 Disposal 6

7 Appendix

7.1 Wiring configuration and connector accessories 6

7.2 Door gap calculation 7

7.3 Load specifications 7

7.4 EC Declaration of conformity 9

1. About this document

1.1 Function

This operating instructions manual provides all the information you need for the mounting, set-up and commissioning to ensure the safe operation and disassembly of the safety switchgear. The operating instructions must be available in a legible condition and a complete version in the vicinity of the device.

1.2 Target group: authorised qualified personnel

All operations described in this operating instructions manual must be carried out by trained specialist personnel, authorised by the plant operator only.

Please make sure that you have read and understood these operating instructions and that you know all applicable legislations regarding occupational safety and accident prevention prior to installation and putting the component into operation.

The machine builder must carefully select the harmonised standards to be complied with as well as other technical specifications for the selection, mounting and integration of the components.

1.3 Explanation of the symbols used



Information, hint, note:

This symbol is used for identifying useful additional information.



Caution: Failure to comply with this warning notice could lead to failures or malfunctions.

Warning: Failure to comply with this warning notice could lead to physical injury and/or damage to the machine.

1.4 Appropriate use

The products described in these operating instructions are developed to execute safety-related functions as part of an entire plant or machine. It is the responsibility of the manufacturer of a machine or plant to ensure the correct functionality of the entire machinery or plant.

The safety switchgear must be exclusively used in accordance with the versions listed below or for the applications authorised by the manufacturer. Detailed information regarding the range of applications can be found in the chapter "Product description".

1.5 General safety instructions

The user must observe the safety instructions in this operating instructions manual, the country-specific installation standards as well as all prevailing safety regulations and accident prevention rules.



Further technical information can be found in the Schmersal catalogues or in the online catalogue on the Internet: www.schmersal.net.

The information contained in this operating instructions manual is provided without liability and is subject to technical modifications.

There are no residual risks, provided that the safety instructions as well as the instructions regarding mounting, commissioning, operation and maintenance are observed.

1.6 Warning about misuse



In case of improper use or manipulation of the safety switch-gear, personal hazards or damages to machinery or plant components cannot be excluded. The relevant requirements of the standard EN 14119 must be observed.

1.7 Exclusion of liability

We shall accept no liability for damages and malfunctions resulting from defective mounting or failure to comply with this operating instructions manual. The manufacturer shall accept no liability for damages resulting from the use of unauthorised spare parts or accessories.

For safety reasons, invasive work on the device as well as arbitrary repairs, conversions and modifications to the device are strictly forbidden; the manufacturer shall accept no liability for damages resulting from such invasive work, arbitrary repairs, conversions and/or modifications to the device.

2. Product description

2.1 Ordering code

This operating instructions manual applies to the following types:

TESK-①-②-③-④-⑤

No.	Option	Description
①	S	Standard hinge
	L	Long hinge half
②	A	preset for front assembly
	I	preset for inside assembly
	U	freely adjustable switching angle
③	22	2 NO contacts / 2 NC contacts
	12	1 NO contacts / 2 NC contacts
	13	1 NO contacts / 3 NC contacts
	02	2 NC contacts
	11	1 NO contacts / 1 NC contacts
④	L1	Cable downwards
	L2	Cable upwards
	ST1	Connector plug bottom
	ST2	Connector plug top
⑤	3M	Cable length 3 m (only L1 / L2)
	5M	Cable length 5 m (only L1 / L2)
	10M	Cable length 10 m (only L1 / L2)
	20M	Cable length 20 m (only L1 / L2)
	30M	Cable length 30 m (only L1 / L2)

2.2 Special versions

For special versions, which are not listed in the order code below 2.1, these specifications apply accordingly, provided that they correspond to the standard version.

2.3 Destination and use

The TESH hinge safety switch has been designed to prevent, in conjunction with the control part of a machine, movable safety guards from being opened before hazardous conditions have been eliminated. They are also suitable for fitting on profile sections and existing equipment.



Hinge safety switches can only be used for applications, in which the hazardous condition is terminated without delay (e.g. run-on movements) when the safety guard is opened.



The user must evaluate and design the safety chain in accordance with the relevant standards and on the required safety level.



The entire concept of the control system, in which the safety component is integrated, must be validated to the relevant standards.

2.4 Technical data

Standards:	IEC 60947-5-1; EN ISO 13849-1; EN 14119; BG-GS-ET-15
Enclosure:	Zinc diecast, enclosure cover self-extinguishing thermoplastic
Hinge pin:	Galvanised steel / Steel C45
Attachment:	4 x M6 screws DIN 7984 or ISO 4762 with TESH-L... 6 screws Tightening torque 4.3 Nm
Contact material:	Silver, gold-plated
Contact type:	Change-over contact with double break Zb
Switching system:	IEC 60947-5-1; Slow action, ⊖ positive break NC contacts
termination:	connector plug M12 or cable
Connector plug:	M12, 5- or 8-pin, A-coded
Connection cable:	Y-UL 2464 / 9 x AWG 22 / 9 x 0.34 mm ² Y-UL 2464 / 5 x AWG 22 / 5 x 0.34 mm ²
Temperature resistance of the cable:	
- at rest:	-25°C ... +80°C
- in motion:	-5°C ... +80°C
Switching angle:	3° adjusted from zero point
Forced opening angle:	10° adjusted from zero point
Positive break torque:	0.35 Nm
Max. swivel angle:	270°
Actuating speed:	max. 180°/0.3 s
Bounce duration:	in accordance with actuating speed
Switchover time:	in accordance with actuating speed
Actuating frequency:	max. 120 operations/h
Mechanical life:	> 1 million operations
Note - mechanical service life:	Switching cycles matched to: Door size: 1 m x 1 m Door weight: 20 kg using an additional hinge according to Section 7.3
Resistance to shock:	30 g / 11 ms
Resistance to vibration:	10 ... 150 Hz, amplitude 0.35 mm
Ambient temperature:	-25 °C ... +65 °C
Storage and transport temperature:	-40 °C ... +85 °C
Protection class:	IP65 to IEC/EN 60529
Protection class:	I
- Plug type:	III
Utilisation category:	AC-15, DC-13
I _e /U _e :	
- Cable design:	2 A / 230 VAC 1 A / 24 VDC
- Plug design:	1 A / 24 VDC
U _i :	
- Cable design:	300 V
- Plug design, M12 8-pin:	30 V (PELV according to DIN EN 60204-1)
- Plug design, M12 5-pin:	60 V
U _{imp} :	
- Cable design:	2.5 kV
- Plug design, M12 8-pin:	0.5 kV
- Plug design, M12 5-pin:	0.8 kV
I _{line} :	2.5 A
U _e max:	230 V Cable version 30 V plug 8 - pin 60 V plug 5 - pin
Max. fuse rating:	2 A gG D-fuse
Switching of low voltages:	1 mA / 3 VDC
Mechanical breaking load (see fig. 1):	
- F1:	5,000 N
- F2:	5,000 N
	See Section 7.3 Load details

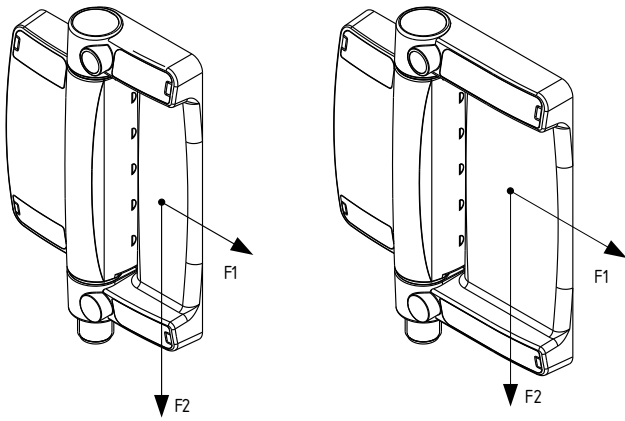

Fig. 1

2.5 Safety classification

Standards:	EN ISO 13849-1
B _{10d} (NC contact):	2.000.000
B _{10d} (NO contact) at 10% ohmic contact load:	1.000.000
Service life:	20 years

$$MTTF_d = \frac{B_{10d}}{0,1 \times n_{op}} \quad n_{op} = \frac{d_{op} \times h_{op} \times 3600 \text{ s/h}}{t_{cycle}}$$

(Specifications can vary depending on the application-specific parameters h_{op} , d_{op} and t_{cycle} as well as the load.)

3. Mounting

3.1 General mounting instructions

Four elongated holes are provided for fixing the switch. To facilitate the alignment of the door to the post, alignment pins are supplied (not for indoor use) that can be inserted into corresponding holes on the bottom of the hinge switch (Fig. 2). Once installed, these can be removed again.

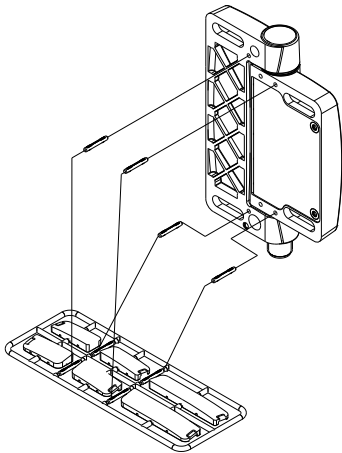

Fig. 2

When used in applications with function for the protection of man, the components must be fitted so that disassembly is prevented (e.g. drill out the hexagonal recess of the fixing screws, blocking the hexagonal recess using a plastic cone diameter 5.1 mm).

The hinge switch furthermore must be pinned after assembly and adjustment (Fig. 3).

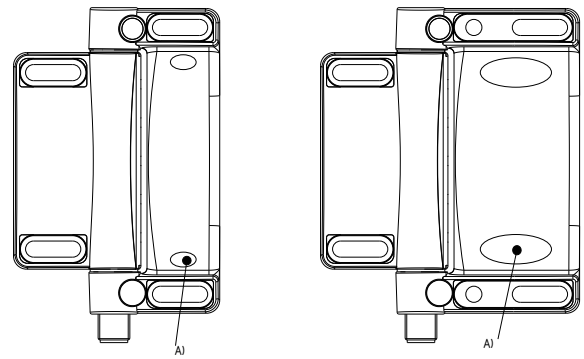

Fig. 3

Legend:

A = Drill and pin in this area



The hinge safety switch must not be used as an end stop.

Any mounting position. The mounting position however is chosen so that the components are preferably fitted in the upper part of the safety guard to avoid the ingress of dirt and soiling as well as damage to the components. In case of painting activities, the components must be covered. Recommended mounting material, see technical data. We recommend that the fixing screws are painted after the component is fitted and to apply the accompanying caps (Figure 4.)



The minimum bending radius must be observed for versions with a cable connection!



Please note the load information "Determining the permissible forces as a function of door size and number of hinges" (see Section 7.3 Load details)



The hinge safety switch must not be used as an end stop. With applications where heavy doors are used and especially when they cannot close easily or without any retardation, additionally measures need to be taken to prevent loosening of the mounting screws.

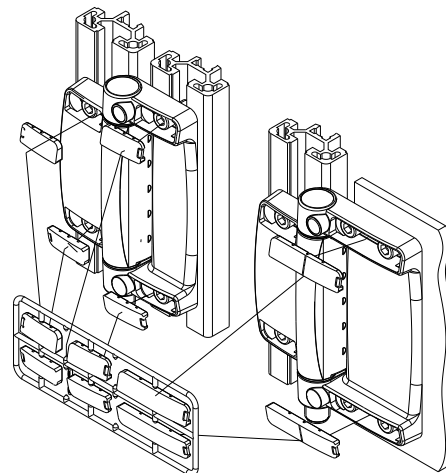

Fig. 4



Please observe the remarks of the standards EN ISO 12100, EN 953 and EN 14119. Also observe the safety distances to the standards EN ISO 13857 and EN 349.

3.2 Adjustment and inspection of the switching angle

After the switch has been fitted, the switching function and the opening angle of the safety guard must be checked. The switching angle of the NC contacts set in factory is approximately 3°.



Caution: for the TESK...-U version, the following paragraph "Special instructions for the on-site setting" imperatively must be observed!

Special instructions for the on-site setting (version TESK...-U)

We recommend a setting including the following steps:

1. Open the safety guard up to the maximum authorised opening angle.
2. Use the adjustment tool to set the NC contacts so that their opening is ensured at the maximum authorised safety guard opening angle. Turn clockwise to decrease the switching angle, turn counterclockwise to increase the switching angle (Fig. 6); when mounted inside accordingly reversed. The positive break angle is 7° larger than the set switching angle.
3. After the switch is set, the compliance of the switch with the safety-technical requirements of the application must be checked. (See Section 7.2 Door gap calculation)
4. After the switching angle has been set and checked, the blanking plug for the adjustment opening located at the rear of the adjustment tool must be inserted in the adjustment opening (1) and torn down by making lateral movements (2) with the tool (Fig. 7).

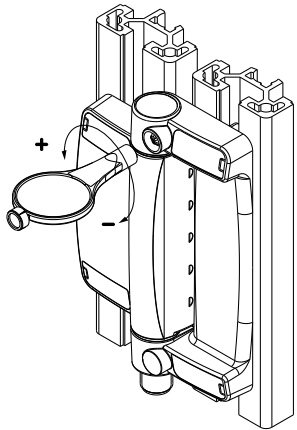

Fig. 6

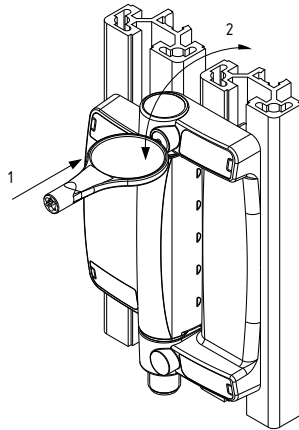

Fig. 7



After the desired switching point is set, the opening of the setting option imperatively must be sealed with a blanking plug. This measure prevents tampering at the set switching point within the meaning of EN 14119 paragraph 5.7 and therefore avoids any loss of the safety function of the device. The blanking plug is injected to the special adjustment tool with a predetermined breaking point. We recommend an additional painting or glueing of the blanking plug. Securing the setting screw by means of the blanking plug is a mandatory instruction for the user, which must be observed in order to maintain the CE-Conformity of the component.

3.3 Dimensions

All measurements in mm.

TESK-S...
TESK-ZS

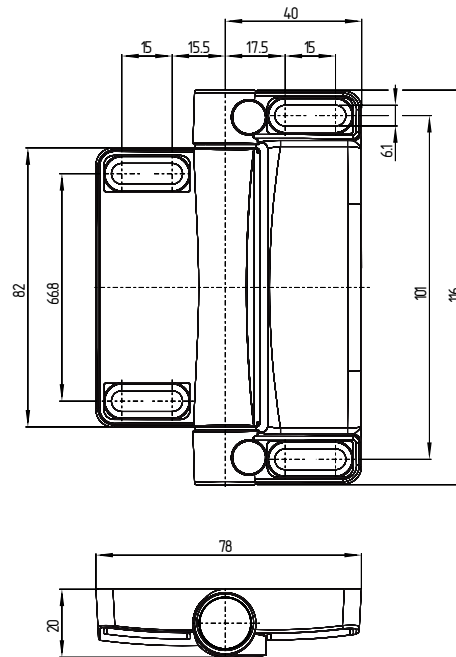

TESK-L...
TESK-ZL

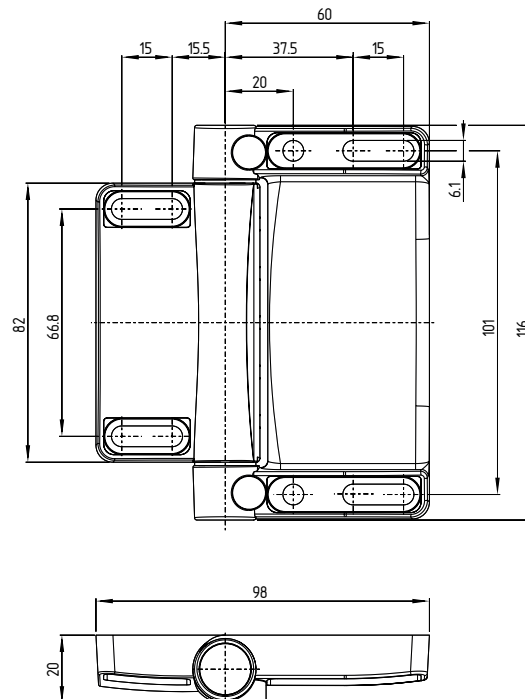

TESK-...ST...

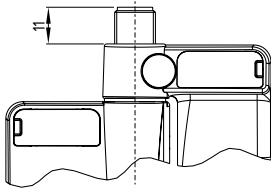

TESK-...L...

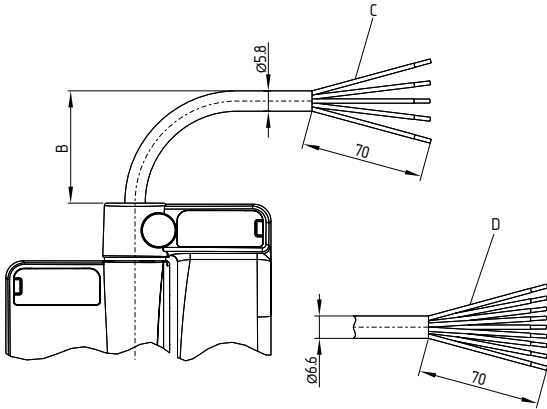

Key

B = Minimum bending radius of the connection cable

C = Cable 5-core (B = 29 mm)

D = Cable 9-core (B = 33 mm)

4. Electrical connection

4.1 General information for electrical connection



The electrical connection may only be carried out by authorised personnel in a de-energised condition. For the connection of different connector versions only connectors with the appropriate protection rating may be used.



The versions TSK-...22ST... and TSK-...13ST... and TSK-...12ST... should only be used PELV circuits in accordance to EN 60204.

4.2 Contact variants

Contacts are shown with safety guard closed.

TESK-...22L...

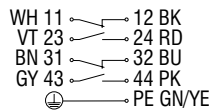

TESK-...13L...

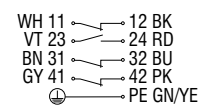

TESK-...12L...

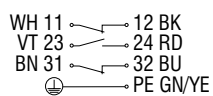

TESK-...02L...

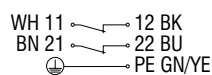

TESK-...11L...

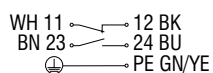

TESK-...22ST...

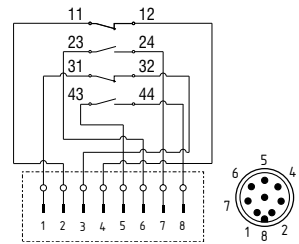

TESK-...13ST...

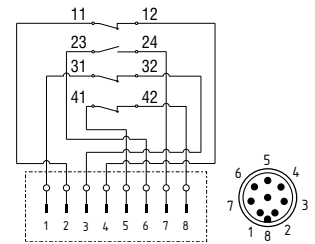

TESK-...12ST...

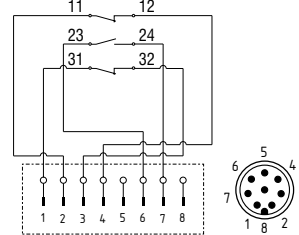

TESK-...02ST...

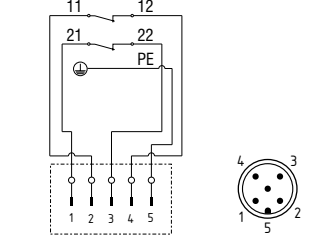

TESK-...11ST...

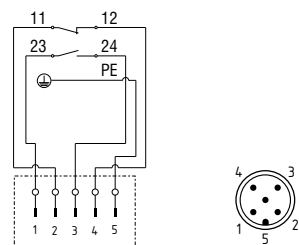

4.3 Switch travel

TESK-...22...

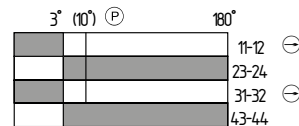

TESK-...13...

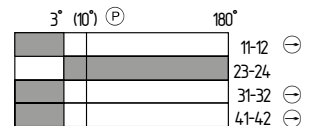

TESK-...12...



TESK-...02...

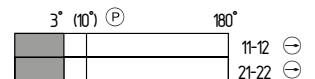

TESK-...11...



Key

⊖ Positive break NC contact

⊕ Positive break travel / -angle

Switching angle tolerance -1° / +3°

5. Set-up and maintenance

5.1 Functional testing

The safety function of the safety components must be tested. The following conditions must be previously checked and met:

1. Correct fixing of the component
2. Check the integrity of the cable entry and connections
3. Check the switch enclosure for damage

5.2 Maintenance

A regular visual inspection and functional test, including the following steps, is recommended:

1. Check fitting of the hinge safety switch
2. Remove particles of dust and soiling
3. Check cable entry and connections
4. Examination of the switching angle

Damaged or defective components must be replaced.

6. Disassembly and disposal

6.1 Disassembly



The safety switchgear must be disassembled in a de-energised condition only.

6.2 Disposal

The safety switchgear must be disposed of in an appropriate manner in accordance with the national prescriptions and legislations.

7. Appendix

7.1 Wiring configuration and connector accessories

Connector plug ST M12, 5-pole		Pin configuration of the connector	Colour code or conductor numbering of the below-mentioned Schmersal connectors		possible colour code of other commercially available connectors	
					to EN 60947-5-2: 2007	DIN 47100
						
Connecting cables with female connector IP67, M12, 5-pole - 5 x 0.25 mm²		1	BN	1	BN	WH
Cable length		2	WH	2	WH	BN
5.0 m	101209949	3	BU	3	BU	GN
15.0 m	101209948	4	BK	4	BK	YE
		5	GY	5	GY	GY
Connector plug ST2 M12, 8-pole		Pin configuration of the connector	Colour code or conductor numbering of the below-mentioned Schmersal connectors		possible colour code of other commercially available connectors	
					to EN 60947-5-2: 2007	DIN 47100
						
Connecting cables with female connector IP67, M12, 8-pole - 8 x 0.23 mm²		1	BN	1	BN	WH
Cable length		2	WH	2	WH	BN
2.5 m	101209963	3	BU	3	BU	GN
5.0 m	101209964	4	BK	4	BK	YE
10.0 m	101209960	5	GY	5	GY	GY
Connecting cables with female connector IP69K, M12, 8-pole - 8 x 0.21 mm²		6	VT	6	PK	PK
Cable length		7	RD	7	VT	BU
5.0 m	101210560	8	PK	8	OR	RD
5.0 m	101210561 (angled)					

Colour code legend

Code	Colour	Code	Colour	Code	Colour	Code	Colour
BK	Black	GN	green	PK	pink	WH	white
BN	brown	GY	grey	RD	red	YE	yellow
BU	blue	OR	orange	VT	violet		

7.2 Door gap calculation

Calculation of the door gap depending on the opening angle, door width and overlapping

β	3°	4°	5°	6°	7°	8°	9°	10°
C	D							
100	5.2	7.0	8.7	10.4	12.2	13.9	15.6	17.4
150	7.8	10.5	13.1	15.7	18.3	20.9	23.5	26.0
200	10.5	13.9	17.4	20.9	24.4	27.8	31.3	34.7
250	13.1	17.4	21.8	26.1	30.5	34.8	39.1	43.3
300	15.7	20.9	26.1	31.3	36.5	41.7	46.9	52.1
350	18.3	24.4	30.5	36.6	42.6	48.7	54.7	60.7
400	20.9	27.9	34.8	41.8	48.7	55.6	62.5	69.4
450	23.5	31.4	39.2	47.0	54.8	62.6	70.4	78.1
500	26.2	34.9	43.6	52.2	60.9	69.6	78.2	86.8
550	28.8	38.3	47.9	57.5	67.0	76.5	86.0	95.5
600	31.4	41.8	52.3	62.7	73.1	83.5	93.8	104.1
650	34.0	45.3	56.6	67.9	79.2	90.4	101.6	112.8
700	36.6	48.8	61.0	73.1	85.3	97.4	109.4	121.5
750	39.2	52.3	65.3	78.4	91.4	104.3	117.3	130.2
800	41.8	55.8	69.7	83.6	97.4	111.3	125.1	138.8
850	44.5	59.3	74.0	88.8	103.5	118.2	132.9	147.5
900	47.1	62.7	78.4	94.0	109.6	125.2	140.7	156.2
950	49.7	66.2	82.8	99.3	115.7	132.1	148.5	164.9
1,000	52.3	69.7	87.1	104.5	121.8	139.1	156.4	173.6
1,050	54.9	73.2	91.5	109.7	127.9	146.1	164.2	182.2
1,100	57.5	76.7	95.8	114.9	134.0	153.0	172.0	190.9
1,150	60.2	80.2	100.2	120.1	140.1	160.0	179.8	199.6
1,200	62.8	83.7	104.5	125.4	146.2	166.9	187.6	208.3
1,250	65.4	87.2	108.9	130.6	152.3	173.9	195.4	217.0
1,300	68.0	90.6	113.2	135.8	158.4	180.8	203.3	225.6
1,350	70.6	94.1	117.6	141.0	164.4	187.8	211.1	234.3
1,400	73.2	97.6	122.0	146.3	170.5	194.7	218.9	243.0
1,450	75.8	101.1	126.3	151.5	176.6	201.7	226.7	251.7
1,500	78.5	104.6	130.7	156.7	182.7	208.7	234.5	260.3

β = Door opening angle

C = Door width in mm

D is the door gap in mm with an overlap at B = 0 mm.

B is the thickness of the door

The actual door gap "D1" is calculated using door gap "D" calculated by means of the table above minus the overlapping "B" of door and frame:
 $D1 = D - B$

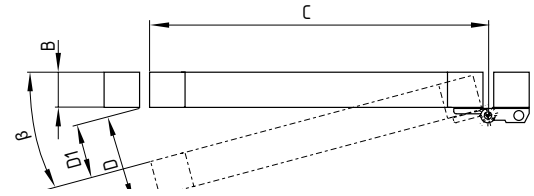

Example:

A door made of 40 mm aluminium profile with a length of 950 mm should be secured with a TESK. The safety contact of the TESK opens to 3° when new according to the technical safety sheet (10° at the end of its service life). The table above shows the door gap when new at approx. 49.7 mm. The real door gap can be calculated with the following equation $D1 = D - B$; $(49.7 - 40 = 9.7)$; $D1 = 9.7$ mm. At the end of the service life the door gap is approx. 164.9 mm and the real door gap is $(164.9 - 40 = 124.9)$; $D1 = 124.9$ mm.

7.3 Load specifications

Determining the permissible forces as a function of door size and number of hinges.

Doors with one hinge

Force [N]		B [mm]				
		100	200	300	400	500
H [mm]	up to 200	200	150	100	70	50
	up to 300	200	150			
not recommended						

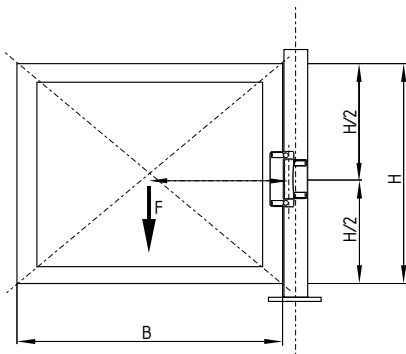

The hinge should be placed in the middle with doors that only have one hinge.

Doors with two hinges

Force [N]	B [mm]									
	400	500	600	700	800	900	1000	1100	1200	
H [mm]	not recommended									
up to 1000	400	400	400	400	400	400	400	400	400	350
up to 1800	400	400	400	400	350	350	300	300	300	250
up to 2400	400	400	400	300	250	250	200	200	200	150
up to 2600	400	400	300	200	150	150	100	100	100	50

Doors with three hinges

Force [N]	B [mm]											
	400	500	600	700	800	900	1000	1100	1200	1300	1400	1500
H [mm]	not recommended											
up to 1800	750	750	750	700	650	650	600	600	550	500	450	400
up to 2400	750	750	700	600	550	550	500	500	450	400	350	300
up to 2600	750	700	600	500	450	450	400	400	400	400	350	300

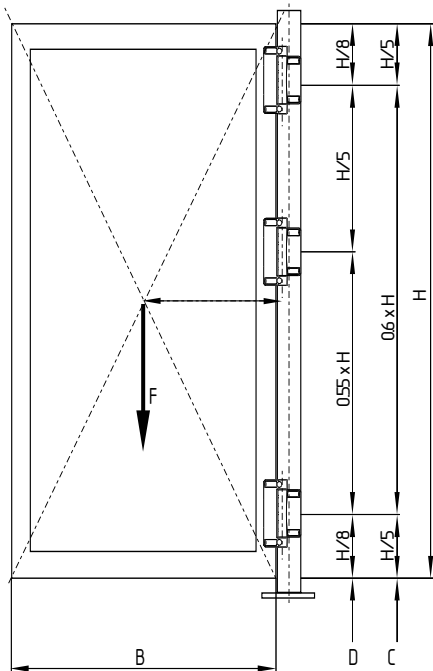

C = Use of one hinge switch and an additional hinge
 D = Use of one hinge switch and two additional hinges



With larger doors the have three hinges make sure the two of the hinges are located in the upper third.



We recommend that the hinge switch is placed in the middle when three hinges are used.



The hinge safety switch must not be used as an end stop. With applications where heavy doors are used and especially when they cannot close easily or without any retardation, additionally measures need to be taken to prevent loosening of the mounting screws.

7.4 EC Declaration of conformity

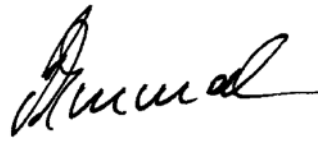
	
<h2>EC Declaration of conformity</h2>	
Translation of the original Declaration of Conformity	K. A. Schmersal GmbH & Co. KG Industrielle Sicherheitssysteme Möddinghofe 30, 42279 Wuppertal Germany Internet: www.schmersal.com
<p>We hereby certify that the hereafter described safety components both in its basic design and construction conform to the applicable European Directives.</p>	
Name of the safety component:	TESK
Type:	Refer to 2.1 Ordering code
Description of the safety component:	Hinge safety switch
Relevant EC-Directives:	2006/42/EC-EC-Machinery Directive
Person authorized for the compilation of the technical documentation:	Oliver Wacker Möddinghofe 30 42279 Wuppertal
Place and date of issue:	Wuppertal, November 27, 2013
TESK-A-EN	
	Authorised signature Philip Schmersal Managing Director



The currently valid declaration of conformity can be downloaded from the internet at www.schmersal.net.



K. A. Schmersal GmbH & Co. KG
Industrielle Sicherheitssysteme
Möddinghofe 30, D - 42279 Wuppertal
Postfach 24 02 63, D - 42232 Wuppertal

Phone: +49 - (0)2 02 - 64 74 - 0
Telefax +49 - (0)2 02 - 64 74 - 1 00
E-Mail: info@schmersal.com
Internet: <http://www.schmersal.com>