



EN Operating instructions.pages 1 to 6
Translation of the original operating instructions

Content

1 About this document

1.1 Function 1

1.2 Target group: authorised qualified personnel. 1

1.3 Explanation of the symbols used 1

1.4 Appropriate use 1

1.5 General safety instructions 1

1.6 Warning about misuse 1

1.7 Exclusion of liability 2

2 Product description

2.1 Ordering code 2

2.2 Special versions. 2

2.3 Destination and use 2

2.4 Technical data 2

2.5 Safety classification 2

3 Mounting

3.1 General mounting instructions 2

3.2 Dimensions 3

4 Electrical connection

4.1 General information for electrical connection. 4

4.2 Contact variants 4

5 Set-up and maintenance

5.1 Functional testing. 4

5.2 Maintenance 4

6 Disassembly and disposal

6.1 Disassembly. 4

6.2 Disposal 4

7 Appendix

7.1 EC Declaration of conformity 5

1. About this document

1.1 Function

This operating instructions manual provides all the information you need for the mounting, set-up and commissioning to ensure the safe operation and disassembly of the safety switchgear. The operating instructions must be available in a legible condition and a complete version in the vicinity of the device.

1.2 Target group: authorised qualified personnel

All operations described in this operating instructions manual must be carried out by trained specialist personnel, authorised by the plant operator only.

Please make sure that you have read and understood these operating instructions and that you know all applicable legislations regarding occupational safety and accident prevention prior to installation and putting the component into operation.

The machine builder must carefully select the harmonised standards to be complied with as well as other technical specifications for the selection, mounting and integration of the components.

1.3 Explanation of the symbols used



Information, hint, note:

This symbol is used for identifying useful additional information.



Caution: Failure to comply with this warning notice could lead to failures or malfunctions.

Warning: Failure to comply with this warning notice could lead to physical injury and/or damage to the machine.

1.4 Appropriate use

The products described in these operating instructions are developed to execute safety-related functions as part of an entire plant or machine. It is the responsibility of the manufacturer of a machine or plant to ensure the correct functionality of the entire machine or plant.

The safety switchgear must be exclusively used in accordance with the versions listed below or for the applications authorised by the manufacturer. Detailed information regarding the range of applications can be found in the chapter "Product description".

1.5 General safety instructions

The user must observe the safety instructions in this operating instructions manual, the country-specific installation standards as well as all prevailing safety regulations and accident prevention rules.



Further technical information can be found in the Schmersal catalogues or in the online catalogue on the Internet: www.schmersal.net.

The information contained in this operating instructions manual is provided without liability and is subject to technical modifications.

There are no residual risks, provided that the safety instructions as well as the instructions regarding mounting, commissioning, operation and maintenance are observed.

1.6 Warning about misuse



In case of improper use or manipulation of the safety switchgear, personal hazards or damages to machinery or plant components cannot be excluded when safety switchgear is used. The relevant requirements of the standard ISO 14119 must be observed.

1.7 Exclusion of liability

We shall accept no liability for damages and malfunctions resulting from defective mounting or failure to comply with this operating instructions manual. The manufacturer shall accept no liability for damages resulting from the use of unauthorised spare parts or accessories.

For safety reasons, invasive work on the device as well as arbitrary repairs, conversions and modifications to the device are strictly forbidden; the manufacturer shall accept no liability for damages resulting from such invasive work, arbitrary repairs, conversions and/or modifications to the device.

2. Product description

2.1 Ordering code

This operating instructions manual applies to the following types:

AZ 16-①ZI-②-③-④

No.	Option	Description
①	03	3 NC contacts
	12	1 NO contact / 2 NC contacts
②	ST	M12 x 1 connector bottom
	STL	M12 x 1 connector LHS
	STR	M12 x 1 connector RHS
③	Actuator:	
	B1	Straight actuator
	B1-1747	Straight actuator with magnetic latch
	B1-2024	Straight actuator with slot lip-seal
	B1-2053	Straight actuator with ball latch
	B1-2177	Straight actuator with centering guide
	B6L	Flexible actuator for left-hand side door hinge
	B6R	Flexible actuator for right-hand side door hinge
④	M16	Cable entry M16
	M20	Cable entry M20



Only if the information described in this operating instructions manual are realised correctly, the safety function and therefore the compliance with the Machinery Directive is maintained.

2.2 Special versions

For special versions, which are not listed in the order code below 2.1, these specifications apply accordingly, provided that they correspond to the standard version.

2.3 Destination and use

The safety switches are suitable for safety fences, flaps and doors, which need to be closed in order to ensure the necessary operational safety.

The safety switches are used for applications, in which the hazardous situation is terminated without delay when the safety guard is opened.

When the safety guard is opened, the NC contacts are positively opened and the NO contacts are closed.



The safety switchgear units are classified as type 2 switchgear in accordance with ISO 14119 and are rated as highly coded.



The user must evaluate and design the safety chain in accordance with the relevant standards and the required safety level.



The entire concept of the control system, in which the safety component is integrated, must be validated to the relevant standards.

2.4 Technical data

Standards:	IEC 60947-5-1, BG-GS-ET-15
Enclosure:	glass-fibre reinforced thermo-plastic, self-extinguishing
Actuator:	stainless steel 1.4301
Coding level according to ISO 14119:	high
Actuating speed:	2 m/s
Max. switching frequency:	4,000 / h
Protection class:	IP67 to IEC 60529
Contact material:	Silver
Contact type:	Change-over with double break, galvanically separated contact bridges
Switching system:	⊖ to IEC 60947-5-1, slow action, positive break NC contact
Connection:	Screw connection, connector M12, 8 pole
Max. cable section:	0.75 ... 2.5 mm ² (incl. conductor ferrules)
Rated impulse withstand voltage U _{imp} :	6 kV
Rated insulation voltage U _i :	500 V
Utilisation category:	AC-15, DC-13
Rated operating current/voltage I _e / U _e :	4 A / 230 VAC 4 A / 24 VDC
- Connector:	2 A / 24 VDC
Required short-circuit current:	1,000 A
Max. fuse rating:	6 A gG D-fuse
Latching force:	approx. 30 N for AZ 16ZI-1747, up to approx. 100 N for AZ 16ZI-2053
Positive break travel:	8 mm
Positive break force:	10 N for each NC contact
Ambient temperature:	-30 °C ... +80 °C
Mechanical life:	> 10 ⁶ operations

2.5 Safety classification

Standards:	ISO 13849-1
Envisaged structure:	
- Basically:	applicable up to Cat. 1 / PL c
- With 2-channel usage and fault exclusion mechanism*:	applicable up to Cat. 3 / PL d with suitable logic unit
B _{10d} NC contact:	2,000,000
B _{10d} NO contact at 10% ohmic contact load:	1,000,000
Service life:	20 years

* If a fault exclusion to the 1-channel mechanics is authorised.

$$MTTF_d = \frac{B_{10d}}{0,1 \times n_{op}} \quad n_{op} = \frac{d_{op} \times h_{op} \times 3600 \text{ s/h}}{t_{cycle}}$$

(Determined values can vary depending on the application-specific parameters h_{op}, d_{op} and t_{cycle} as well as the load.)

If multiple safety components are wired in series, the Performance Level to ISO 13849-1 will be reduced due to the restricted error detection under certain circumstances.

3. Mounting

3.1 General mounting instructions

The mounting dimensions are indicated on the rear of the component. The enclosure must not be used as an end stop. Any mounting position. The mounting position however must be chosen so that the ingress of dirt and soiling in the used opening is avoided. The non-used actuator openings must be sealed with sealing plugs after fitting.

Fit the individually coded actuator to the correct side, refer to the contour of the actuator represented on the switch enclosure. Provide for a direct positive linkage between the actuator and the safety guard. Please observe that, when fixing the switch e.g. by means of riveting or welding, the insertion depth of the actuator is not modified.



The safety component and the actuator must be permanently fitted to the safety guards and protected against displacement by suitable measures (tamperproof screws, gluing, drilling, pinning).



Please observe the remarks of the standards ISO 12100, EN 953 and ISO 14119.

Actuating radii of the actuator

When the switch is fitted on a hinged safety guard, please ensure that the point of rotation is located within the range of the upper surface of the safety switch, in which the actuator hook is inserted (refer to table).

Note

The ball latch (-2053) must be adjusted after the switch is fitted to the safety guard. Uniformly adjust the screws of the ball latch by means of a screwdriver to this effect.

Actuating radii		R_{min}		R_{min}	
		R_{min} [mm]	d [mm]	R_{min} [mm]	d [mm]
	B6L	120	11	60	11
	B6R	120	11	60	11
	B1	-	-	-	-
	B1-1747	-	-	-	-
	B1-2024	-	-	-	-
	B1-2053	-	-	-	-
	B1-2177	-	-	-	-

Key

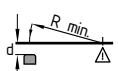

Actuating radius over the small edge of the actuator

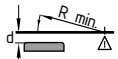

Actuating radius over the wide edge of the actuator

The axis of the hinge must be d mm above and in a parallel plane to the top surface of the safety switch. The basis setting provides a minimum radius of R_{min} .

3.2 Dimensions

All measurements in mm.

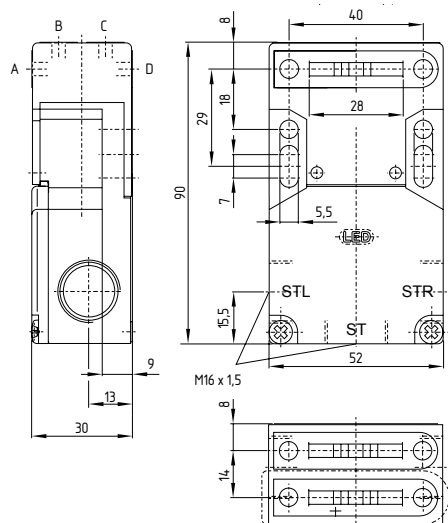

Key

A - D 4 actuating holes

Straight actuator B1

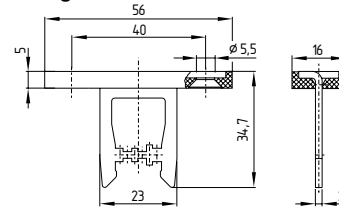

Straight actuator B1-1747 With magnetic latch

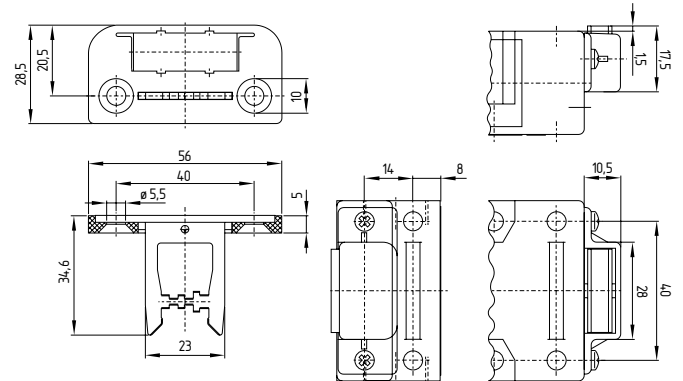

Straight actuator B1-2024 With slot lip-seal

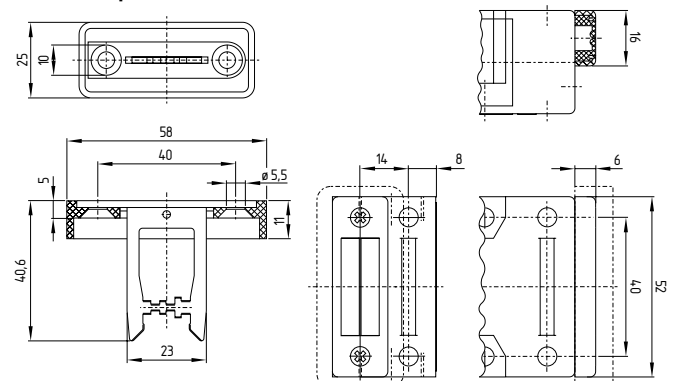

Straight actuator B1-2053 With ball latch

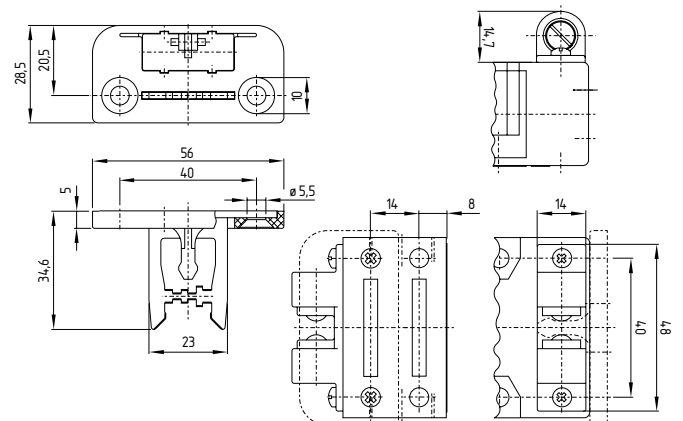

Straight actuator B1-2177 With centering guide

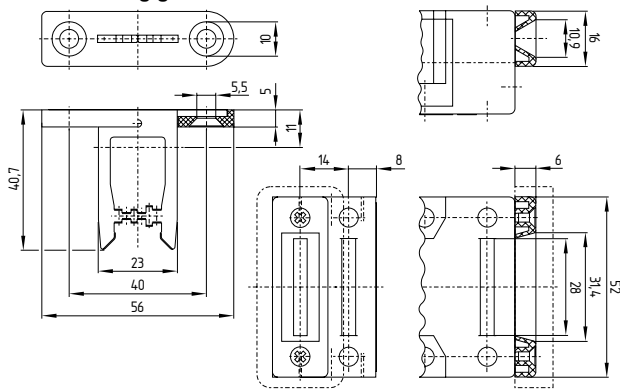

Flexible actuator B6L/B6R

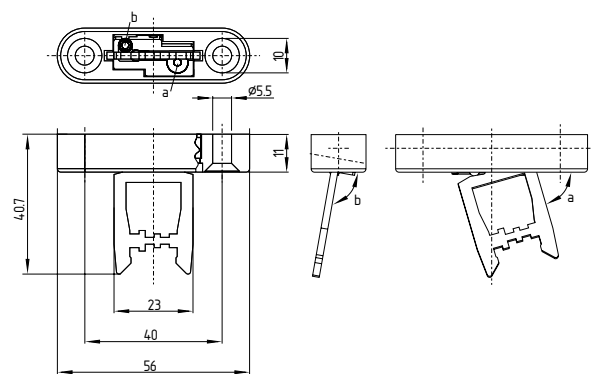

Setting screw

For larger radius, the angle has to be adjusted correspondingly by turning the set screws a and b, using an hexagonal key wrench 2.5 mm A/F. The basis setting provides a minimum radius.

4. Electrical connection

4.1 General information for electrical connection



The electrical connection may only be carried out by authorised personnel in a de-energised condition.

The contact labelling can be found in the wiring compartment of the switch. Appropriate cable glands with a suitable degree of protection are to be used. To this effect, three cable entries are available, which can be broken out if necessary. After wiring, dust and soiling must be removed from the wiring compartment. The safety switch is double insulated. The use of a protective ground connector therefore is not authorised.

4.2 Contact variants

Contacts are shown with safety guard closed.

AZ 16-12ZI 1 NO / 2 NC

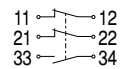

AZ 16-03ZI 3 NC

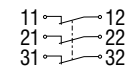

AZ 16-12ZI-ST. 1 NO / 2 NC with connector

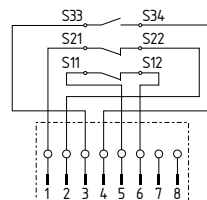

5. Set-up and maintenance

5.1 Functional testing

The safety function of the safety components must be tested. The following conditions must be previously checked and met:

1. Check for correct installation of the actuator and the switch.
2. Check the integrity of the cable entry and connections.
3. Check the switch enclosure for damage.

5.2 Maintenance

In case of correct installation in accordance with the instructions described above, the component requires little maintenance. For use in extreme conditions, we recommend routine maintenance including the following steps:

1. Check for correct installation of the actuator and the switch.
2. Remove particles of dust and soiling.
3. Check cable entry and connections.



Throughout the operative life cycles of the safety switchgear, suitable constructive and organisational measures are to be taken to prevent against tampering and to prevent the safety device being overridden.

Damaged or defective components must be replaced.

6. Disassembly and disposal

6.1 Disassembly



The safety switchgear must be disassembled in a de-energised condition only.

6.2 Disposal

The safety switchgear must be disposed of in an appropriate manner in accordance with the national prescriptions and legislations.

7. Appendix

7.1 EC Declaration of conformity

	
<h2>EC Declaration of conformity</h2>	
Translation of the original Declaration of Conformity	ACE Schmersal Eletroeletrônica Industrial Ltda. Av. Brasil, nº 815 Vila Esplanada CEP: 18550-000 Boituva – SP Brazil Internet: www.schmersal.com.br
We hereby certify that the hereafter described safety components both in its basic design and construction conform to the applicable European Directives.	
Name of the safety component:	AZ 16ZI
Description of the safety component:	Positive break position switch with separate actuator for safety functions
Relevant EC-Directives:	2006/42/EC - EC-Machinery Directive
Person authorised for the compilation of the technical documentation:	Oliver Wacker Möddinghofe 30 42279 Wuppertal
Place and date of issue:	Boituva, 26. March 26, 2014
ACE-AZ16ZI-B-EN	
	Authorised signature Marco Antonio De Dato Head of Engineering and Design



The currently valid declaration of conformity can be downloaded from the internet at www.schmersal.net.



K.A. Schmersal GmbH & Co. KG
Möddinghofe 30, D - 42279 Wuppertal
Postfach 24 02 63, D - 42232 Wuppertal

Phone +49 - (0)2 02 - 64 74 - 0
Telefax: +49 - (0)2 02 - 64 74 - 1 00
E-Mail: info@schmersal.com
Internet: <http://www.schmersal.com>

Production site:
ACE Schmersal
Eletroeletrônica Industrial Ltda.
Av. Brasil, nº 815
Jardim Esplanada – CEP: 18550-000, Boituva – SP
Brazil
Phone +55 - (0)15 - 32 63 - 9866
Fax +55 - (0)15 - 32 63 - 9890
E-Mail: vendas@schmersal.com.br
Internet: <http://www.schmersal.com.br>

K.A. Schmersal GmbH & Co. KG
Möddinghofe 30, D - 42279 Wuppertal
Postfach 24 02 63, D - 42232 Wuppertal

Phone +49 - (0)2 02 - 64 74 - 0
Telefax: +49 - (0)2 02 - 64 74 - 1 00
E-Mail: info@schmersal.com
Internet: <http://www.schmersal.com>

Production site:

ACE Schmersal

Eletroeletrônica Industrial Ltda.

Av. Brasil, nº 815

Jardim Esplanada – CEP: 18550-000, Boituva – SP

Brazil

Phone +55 - (0)15 - 32 63 - 9866
Fax +55 - (0)15 - 32 63 - 9890
E-Mail: vendas@schmersal.com.br
Internet: <http://www.schmersal.com.br>