



**EN** Operating instructions..... pages 1 to 8  
Translation of the original operating instructions

**FR** Vous trouverez la version actuelle du mode d'emploi dans votre langue nationale officielle sur l'Internet, [www.schmersal.net](http://www.schmersal.net).

**ES** Encontrará el manual de instrucciones actual en su idioma oficial de la UE en nuestra página de Internet [www.schmersal.net](http://www.schmersal.net).

**NL** U vindt de huidige versie van de gebruikshandleiding in uw officiële landstaal op het Internet, [www.schmersal.net](http://www.schmersal.net).

**IT** Il manuale d'istruzioni aggiornato nella vostra lingua (lingua ufficiale UE) è scaricabile in Internet all'indirizzo [www.schmersal.net](http://www.schmersal.net).

**JP** EU公用語で書かれた最新の取扱説明書は、インターネット ([www.schmersal.net](http://www.schmersal.net)) からダウンロードできます。

## Content

<b>1 About this document</b>	
1.1 Function	1
1.2 Target group: authorised qualified personnel	1
1.3 Explanation of the symbols used	1
1.4 Appropriate use	1
1.5 General safety instructions	1
1.6 Warning about misuse	1
1.7 Exclusion of liability	2
<b>2 Product description</b>	
2.1 Ordering code	2
2.2 Special versions	2
2.3 Destination and use	2
2.4 Technical data	2
2.5 Safety classification	3
<b>3 Mounting</b>	
3.1 General mounting instructions	3
3.2 Dimensions	3
<b>4 Electrical connection</b>	
4.1 General information for electrical connection	3
<b>5 Operating principle and diagnostic functions</b>	
5.1 Safety switch with conventional diagnostic output	4
5.2 Safety switch with serial diagnostic function	5
<b>6 Set-up and maintenance</b>	
6.1 Functional testing	5
6.2 Maintenance	5
<b>7 Disassembly and disposal</b>	
7.1 Disassembly	5
7.2 Disposal	5
<b>8 Appendix</b>	
8.1 Wiring examples	6
8.2 Wiring	6
8.3 EC Declaration of conformity	7

## 1 About this document

### 1.1 Function

This operating instructions manual provides all the information you need for the mounting, set-up and commissioning to ensure the safe operation and disassembly of the safety switchgear. The operating instructions must be available in a legible condition and a complete version in the vicinity of the device.

### 1.2 Target group: authorised qualified personnel

All operations described in this operating instructions manual must be carried out by trained specialist personnel, authorised by the plant operator only.

Please make sure that you have read and understood these operating instructions and that you know all applicable legislations regarding occupational safety and accident prevention prior to installation and putting the component into operation.

The machine builder must carefully select the harmonised standards to be complied with as well as other technical specifications for the selection, mounting and integration of the components.

### 1.3 Explanation of the symbols used



#### Information, hint, note:

This symbol is used for identifying useful additional information.



**Caution:** Failure to comply with this warning notice could lead to failures or malfunctions.

**Warning:** Failure to comply with this warning notice could lead to physical injury and/or damage to the machine.

### 1.4 Appropriate use

The products described in these operating instructions are developed to execute safety-related functions as part of an entire plant or machine. It is the responsibility of the manufacturer of a machine or plant to ensure the proper functionality of the entire machinery or plant.

The safety switchgear must be exclusively used in accordance with the versions listed below or for the applications authorised by the manufacturer. Detailed information regarding the range of applications can be found in the chapter "Product description".

### 1.5 General safety instructions

The user must observe the safety instructions in this operating instructions manual, the country-specific installation standards as well as all prevailing safety regulations and accident prevention rules.



Further technical information can be found in the Schmersal catalogues or in the online catalogue on the Internet: [www.schmersal.net](http://www.schmersal.net).

The information contained in this operating instructions manual is provided without liability and is subject to technical modifications.

There are no residual risks, provided that the safety instructions as well as the instructions regarding mounting, commissioning, operation and maintenance are observed.

### 1.6 Warning about misuse



In case of inadequate or improper use or manipulations of the safety switchgear, personal hazards or damage to machinery or plant components cannot be excluded. The relevant requirements of the standard EN 1088 must be observed.

### 1.7 Exclusion of liability

We shall accept no liability for damages and malfunctions resulting from defective mounting or failure to comply with this operating instructions manual. The manufacturer shall accept no liability for damages resulting from the use of unauthorised spare parts or accessories.

For safety reasons, invasive work on the device as well as arbitrary repairs, conversions and modifications to the device are strictly forbidden; the manufacturer shall accept no liability for damages resulting from such invasive work, arbitrary repairs, conversions and/or modifications to the device.

## 2 Product description

### 2.1 Ordering code

This operating instructions manual applies to the following types:

AZ 200 <sup>①</sup> -T- <sup>②</sup>		
No.	Option	Description
①	SK	Screw terminals
	CC	Cage clamps
	ST1	M23 x 1 connector (8+1) pole
	ST2	M12 x 1 connector, 8 pole
②	<b>Outputs</b>	
	1P2P	1 p-type diagnostic output and 2 p-type safety outputs
	3P2P	3 p-type diagnostic output and 2 p-type safety outputs
	SD2P	serial diagnostic output and 2 p-type safety outputs



Only if the information described in this operating instructions manual are realised correctly, the safety function and therefore the compliance with the Machinery Directive is maintained.

### 2.2 Special versions

For special versions, which are not listed in the order code below 2.1, these specifications apply accordingly, provided that they correspond to the standard version.

### 2.3 Destination and use

The AZ 200 with non-contact electronic safety sensors is designed for application in safety circuits and is used for monitoring the position of movable safety guards. The integrated door detection sensor monitors the closed condition of the safety guard, the sensor of the actuator monitors the actuator position. The safety function consists of safely switching off the safety outputs when the safety guard is opened and maintaining the safe switched off condition of the safety outputs for as long as the safety guard is open. The opening of the safety guard is detected by the safety sensors.

### LED functions

The safety switchgear signals the operational state as well as errors through three coloured LED's installed on the front side of the device.

**green:** supply voltage on  
**red:** Error (see flash codes)  
**yellow:** operating condition

### 2.4 Technical data

Standards:	IEC 60947-5-3, EN ISO 13849-1, IEC 61508
Material of the enclosure:	glass-fibre reinforced thermoplastic, self-extinguishing
Mechanical life:	≥ 1 million operations
Latching force:	30 N
Protection class:	IP 67 to IEC/EN 60529
Insulation protection class:	II, $\square$
Overvoltage category:	III
Degree of pollution:	3

Realisation of the electrical connection:	Screw terminals or cage clamps, M12 or M23 connector
Cable section:	min. 0.25 mm <sup>2</sup> , max. 1.5 mm <sup>2</sup> (including conductor ferrules)
Tightening torque for the cover screws:	0.7 ... 1 Nm (Torx T10)
Cable entry:	M20 x 1.5
Series wiring:	max. 31 components (not applicable for ordering suffix -3P2P)
Cable length:	max. 200 m (cable length and cable section alter the voltage drop depending on the output current)
Switching distances to IEC 60947-5-3:	
Rated operating distance $s_n$ :	6.5 mm
assured switching distance $s_{ao}$ :	4.0 mm
assured switch-off distance $s_{ar}$ :	30 mm
Hysteresis:	max. 1.5 mm
Repeat accuracy R:	< 0,5 mm
Ambient conditions:	
Ambient temperature:	- 25°C ... + 70°C
Storage and transport temperature:	- 25°C ... + 85°C
Resistance to vibrations:	10 ... 55 Hz, amplitude 1 mm
Resistance to shock:	30 g / 11 ms
Switching frequency:	1 Hz
Response time:	< 60 ms
Duration of risk:	< 120 ms
Time to readiness:	< 4000 ms
Max. actuating speed:	≤ 0.2 m/s
Electrical data:	
Rated operating voltage $U_{e1}$ :	24 VDC -15% / +10% (stabilised PELV)
Operating current $I_e$ :	0.7 A
No-load current $I_o$ :	max. 0.1 A
Rated impulse withstand voltage $U_{imp}$ :	0.8 kV
Rated insulation voltage $U_i$ :	32 VDC
Device fuse rating:	internal short-circuit proof
Screw terminals or cage clamps:	≤ 4 A when used to UL 508
Connector M12:	≤ 2 A
Connector M23:	≤ 4 A
EMC rating:	to EN 61000-6-2
Safety inputs:	X1 and X2 (-1P2P and -SD2P)
Rated operating voltage $U_{e3}$ :	- 3 V ... 5 V ( Low) 15 V ... 30 V ( High)
Rated operating current $I_{e3}$ :	typically 2 mA at 24V
Safety outputs:	Y1 and Y2, p-type, short-circuit proof
Rated operating voltage $U_{e1}$ :	0 V ... 4 V under $U_e$
Rated operating current $I_{e1}$ :	max. 0.25 A each
Utilisation category:	DC-13
Leakage current $I_r$ :	≤ 0,5 mA
Diagnostic output OUT/OUT2/OUT3:	short-circuit proof, p-type
Rated operating voltage $U_{e2}$ :	0 V ... 4 V under $U_e$
Rated operating current $I_{e2}$ :	-1P2P: max. 0.05 A -3P2P: max. 0.1 A ( $I_{out} + I_{out2} + I_{out3} \leq I_{e2}$ )
Utilisation category:	DC-13
Wiring capacitance for serial diagnostics:	max. 50 nF



1. Use isolated power supply only
2. For use in NFPA 79 Applications only
3. Adapters providing field wiring means are available from the manufacturer. Refer to manufacturers information.

2.5 Safety classification

Standards:	EN ISO 13849-1, IEC 61508, IEC 60947-5-3
PL:	up to e
Control category:	up to 4
PFH value:	$4 \times 10^{-9} / h$
SIL:	up to 3
Service life:	20 years
Classification:	PDF-M

3 Mounting

3.1 General mounting instructions

For fitting the AZ 200 T safety switch and the actuator, two mounting holes for M6 screws with washers (washers included in delivery) are provided. The safety switch must not be used as end stop. Any mounting position. The unused opening must be sealed by means of slot sealing plugs. The unused actuator opening must be sealed by means of the dust-proof flap (included in delivery).



Please observe the remarks of the standards EN ISO 12100, EN 953 and EN 1088.

Admissible mounting set-up

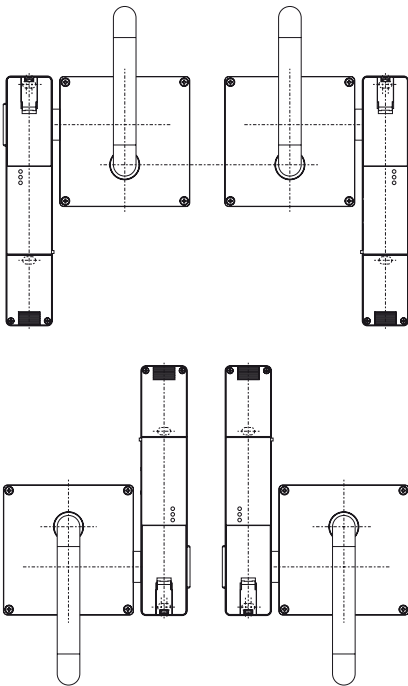

Inadmissible mounting set-up

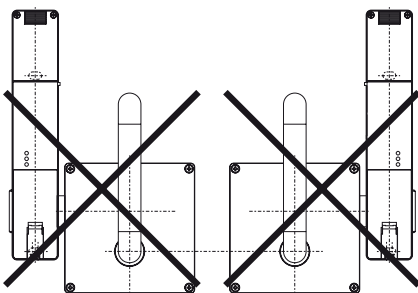

Mounting of the actuators and the safety switches

Refer to the mounting instructions manual for the corresponding actuator.

3.2 Dimensions

All measurements in mm.

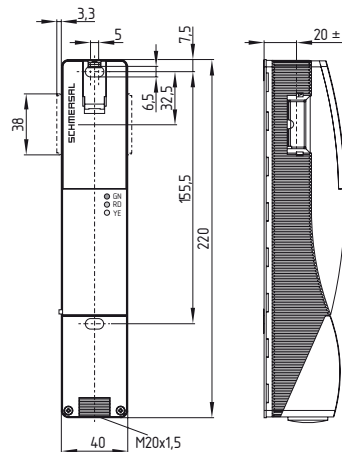

4 Electrical connection

4.1 General information for electrical connection



The electrical connection may only be carried out by authorised personnel in a de-energised condition.

The power supply for the safety switch must provide protection against permanent overvoltage. To that effect, stabilised PELV supply units must be used. The safety outputs can be directly integrated in the safety circuit of the control system. For applications up to PL e / control category 4 to EN ISO 13849-1, the safety outputs of the safety switch (max. 31 components in a series-wiring) must be connected to a safety-monitoring module of the same control category (refer to wiring examples). Inductive loads (e.g. contactors, relays, etc.) are to be provided with suitable interference suppression circuitry.

Requirements for the connected safety-monitoring module:

- Dual-channel safety input suitable for 2 p-type semi-conductor outputs
- Test function

The safety-monitoring module must tolerate internal functional tests of the sensors with cyclic switch-off of the sensor outputs for max. 2 ms (typically < 1 ms). The switch-off stage of the test cycle is temporarily reduced by an active ohmic discharge of the cable. The safety-monitoring module does not need to have a cross-wire short monitoring function, if necessary, the cross-wire short monitoring function must be disabled.

Cable

The cable entry is realised by a metric M20 x 1.5 gland. This gland must be dimensioned by the user so that it is suitable for the cable used. A cable gland with strain relief and suitable IP protection class must be used.

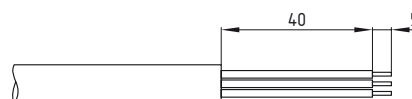

The maximum cable length is 200 m (for ST2 M12 connectors approx. 20 m depending on the cable section used for an operating current of 0.5 A). The maximum cable section is 1.5 mm<sup>2</sup>, incl. conductor ferrules. Prior to the connection, the cable must be stripped by 40+5 mm and insulated by 5 mm. The fitted -1V, X2, X2 bridge is included in the delivery of ...24P1P and ...-SD2P.

5 Operating principle and diagnostic functions

5.1 Safety switch with conventional diagnostic output

Mode of operation of the safety outputs

The opening of the safety guard causes the safety outputs to be disabled within the risk time.

Recommended suitable safety-monitoring modules

Control category 4, PL e: SRB 031MC, SRB 301LC/B,  
SRB 301ST, SRB 304ST, SRB  
324ST, PROTECT PSC

Control category 3, PL d: AES 1135, AES 1235

Operating principle of the electronic diagnostic output

The short-circuit proof diagnostic output can be used for central visualisation or control functions, e.g. in a PLC. The closed condition of the safety guard and the inserted condition of the actuator is indicated by means of a 24V signal.

**The diagnostic output is not a safety-related output!**

Diagnostic outputs

The AZ 200 .-.1P2P safety switch has a diagnostic output: **OUT**

**OUT:** door closed, actuator inserted and no fault detected

The AZ 200 .-.3P2P safety switch has three diagnostic outputs:

**OUT, OUT2, OUT3**

**OUT:** door closed, actuator inserted

**OUT2:** Error warning

**OUT3:** Guard door detected

The diagnostic outputs are protected against short-circuits by means of a common current limitation circuit.

Therefore:  $I_{OUT} + I_{OUT2} + I_{OUT3} \leq I_{e2}$

Error

Errors, which no longer guarantee the function of the AZ 200 T (internal errors) cause the safety outputs to be disabled. Any error that does not immediately affect the safe functionality of the AZ 200 T safety switch (e.g. the ambient temperature too high, interference potential at a safety output, cross-wire short) will lead to a delayed shut-down (refer to table 2).

After fault rectification, the sensor can be reset by opening and closing the relevant guard door. The safety outputs enable and allow a restart.



If more than one fault is detected at the safety outputs, the AZ 200 will be electronically locked and a normal fault reset will no longer be possible. The AZ 200 locks itself when the following faults occur; in that case, the component can only be reset by switching off the operating voltage.

- Cross-wire short at the enabled safety outputs
- both safety outputs (Y1 and Y2) bridged at +U<sub>b</sub>

Error warning

A fault has occurred, which causes the safety outputs to be disabled after 30 minutes. The safety outputs initially remain enabled. In this way, the process can be shutdown in a controlled manner. An error warning is deleted in the slave when the error cause is eliminated.

Table 1: the diagnostic function of the AZ 200 safety switch

The safety switchgear signals the operational state as well as errors through three coloured LED's installed on the front side of the device.

System condition	LED	LED	LED	Safety outputs	Diagnostic outputs			
					-1P2P	-3P2P		
	green	red	yellow	Y1, Y2	OUT	OUT	OUT2	OUT3
guard open	On	Off	Off	0 V	0 V	0 V	0 V	0 V
Door closed, actuator not inserted	On	Off	Off	0 V	0 V	0 V	0 V	24 V
Door closed, actuator inserted	On	Off	On	24 V (if X1 = X2 = 24 V)	24 V	24 V	0 V	24 V
<b>Error warning<sup>1)</sup>, actuator inserted, shutdown approaching</b>	On	flashes <sup>2)</sup>	On	24 V (if X1 = X2 = 24 V)	0 V	24 V	24 V	24 V
<b>Error</b>	On	Flashes	Off	0 V	0 V	24 V/0 V	24 V	24 V/0 V

<sup>1)</sup> after 30 min -> 0 V

<sup>2)</sup> refer to flash code

Table 2: flash codes red LED

Flash codes (red)	Description	Autonomous switch-off after	Error cause
1 flash pulse	Error (warning) at output Y1	30 min	Fault in output test or voltage at output Y1, although the output is disabled.
2 flash pulses	Error (warning) at output Y2	30 min	Fault in output test or voltage at output Y2, although the output is disabled.
3 flash pulses	Error (warning) cross-wire short	30 min	Cross-wire short between the output cables or fault at both outputs
4 flash pulses	Error (warning) temperature too high	30 min	The temperature measurement reveals an internal temperature that is too high
5 flash pulses	Actuator fault	0 min	Wrong or defective actuator
6 flash pulses	Error actuator combination	0 min	An invalid combination of targets was detected at the 4 coils of the AZ 200.-T. (Currently set: blocking bolt detected & door target not detected => blocking bolt breakage detection or tamper attempt)
continuous red signal	internal error	0 min	

**5.2 Safety switch with serial diagnostic function**

Safety switches with serial diagnostic cable have a serial input and output cable instead of the conventional diagnostic output. If safety switches are wired in series, the diagnostic data are transmitted through the series-wiring of the inputs and outputs.

Max. 31 safety switches can be wired in series. For the evaluation of the serial diagnostic cable, either the PROFIBUS-Gateway SD-I-DP-V0-2 or the Universal Gateway SD-I-U... are used. This serial diagnostic interface is integrated as slave in an existing field bus system. In this way, the diagnostic signals can be evaluated by means of a PLC.

The response data and the diagnostic data are automatically and permanently written in an input byte of the PLC for each safety switch in the series-wired chain. In case of a communication error between the field bus gateway and the safety switch, the switching condition of the interlocking device is maintained.

**Error**

A fault has occurred, which causes the safety outputs to be disabled. The fault is reset, when the cause is eliminated and bit 7 of the request byte changes from 1 to 0 or the safety guard is opened.

Faults at the safety outputs are only deleted upon the next release, as the fault rectification cannot be detected sooner.



If more than one fault is detected at the safety outputs, the AZ 200 will be electronically locked and a normal fault reset will no longer be possible. The AZ 200 locks itself when the following faults occur; in that case, the component can only be reset by switching off the operating voltage.

- Cross-wire short at the enabled safety outputs
- both safety outputs (Y1 and Y2) bridged at +U<sub>b</sub>

**Error warning**

A fault has occurred, which causes the safety outputs to be disabled after 30 minutes. The safety outputs initially remain enabled. In this way, the process can be shutdown in a controlled manner. An error warning is deleted when the error cause is eliminated.

**Diagnostic error (warning)**

If an error (warning) is signalled in the response byte, detailed fault information can be read out.

**Flash codes red LED refer to table 2**

**Accessories for the series-wiring**

To provide for a comfortable wiring and series-wiring of SD components, the SD junction boxes SD-2V-F-SK (variant for the field in closed enclosure) and SD-2V-S-SK (variant for DIN rail mounting in the control cabinet) are available.

**6 Set-up and maintenance**

**6.1 Functional testing**

The safety function of the safety components must be tested. The following conditions must be previously checked and met:

1. Check max. axial misalignment of actuator and safety switchgear
2. Check fixation of the safety switch and the actuator
3. Check the integrity of the cable entry and connections
4. Check the switch enclosure for damage.

**6.2 Maintenance**

A regular visual inspection and functional test, including the following steps, is recommended:

1. Check max. axial misalignment of actuator and safety switchgear
2. Check fixation of the safety switch and the actuator
3. Remove particles of dust and soiling
4. Check cable entry and connections

**Damaged or defective components must be replaced.**

**7 Disassembly and disposal**

**7.1 Disassembly**

The safety switchgear must be disassembled in a de-energised condition only.

**7.2 Disposal**

The safety switchgear must be disposed of in an appropriate manner in accordance with the national prescriptions and legislations.

**Table 3: I/O data and diagnostic data**

Bit n°	Request byte	Response byte	Diagnostic error warning	Diagnostic error
Bit 0:	---	Safety output activated	Error output Y1	Error output Y1
Bit 1:	---	Actuator detected	Error output Y2	Error output Y2
Bit 2:	---	---	Cross-wire short	Cross-wire short
Bit 3:	---	---	Temperature too high	Temperature too high
Bit 4:	---	Input condition X1 and X2	---	Wrong or defective actuator
Bit 5:	---	Guard door detected	Internal device error	Internal device error
Bit 6:	---	Error warning	Communication error between the field bus Gateway and the safety switch	---
Bit 7:	Error reset	Error (enabling path switched off)	---	---

The described condition is reached, when bit = 1

8 Appendix

8.1 Wiring examples

The application examples shown are suggestions. They however do not release the user from carefully checking whether the switchgear and its set-up are suitable for the individual application.

Wiring example 1: AZ 200.-T-1P2P.

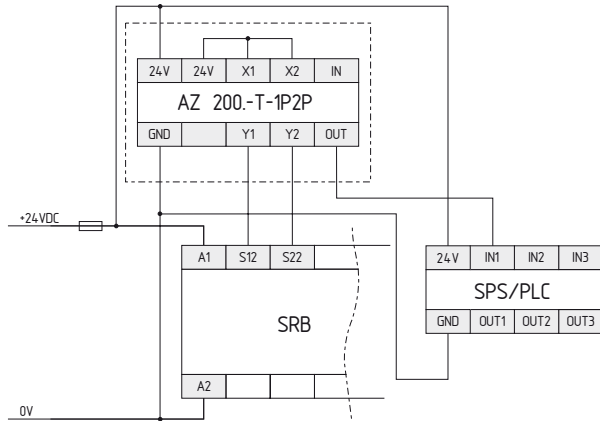

Wiring example 2: AZ 200.-T-3P2P.

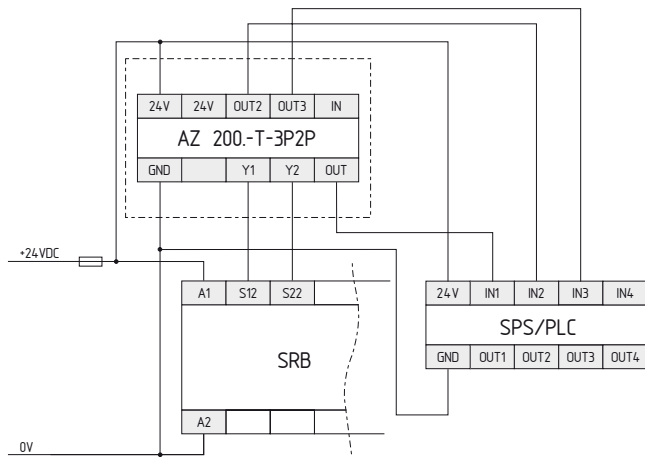

Wiring example 3: series-wiring of the AZ 200.-T-1P2P.

The series-wiring of multiple AZM 200 solenoid interlocks is realised by wiring in the control cabinet or in on-site junction boxes.

In the example, 3 AZ 200.-T-1P2P safety switches (max. 31 components) are wired in series. The diagnostic output ("OUT") are separately wired to a conventional PLC for evaluation or control. The maximum cable length of the safety circuits must not exceed 200 m.

In the series-wiring, the 24V-X1-X2 bridge must be removed from all components up to the last component (refer to wiring example).

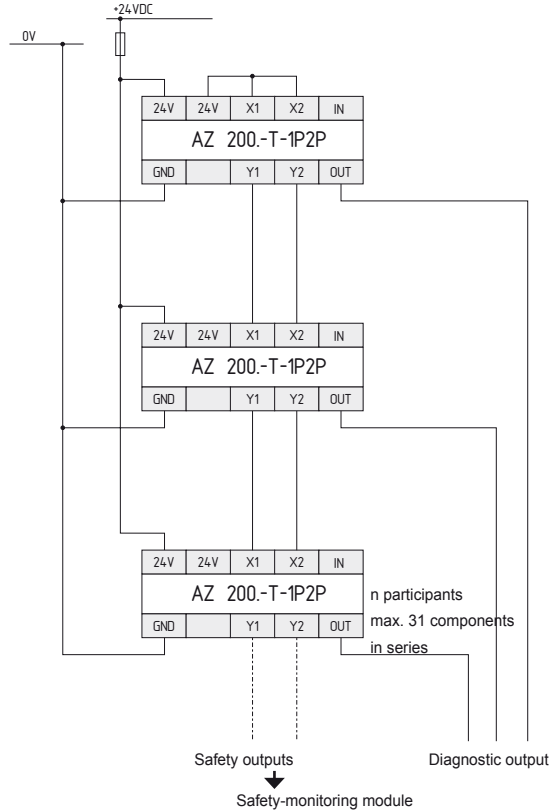

8.2 Wiring

Table 4: wiring of the solenoid interlock with cable or with integrated connector

Pin configuration of the version with connector	Wiring, safety switch with 1 diagnostic output ...-1P2P	Wiring, safety switch with serial diagnostic ...-SD2P	Wiring, safety switch with 3 diagnostic outputs ...-3P2P
Pin 1	24 V Operating voltage	24 V Operating voltage	24 V Operating voltage
Pin 2	X1 Safety input 1	X1 Safety input 1	OUT 2 diagnostic output 2
Pin 3	GND Ground	GND Ground	GND Ground
Pin 4	Y1 Safety output 1	Y1 Safety output 1	Y1 Safety output 1
Pin 5	OUT diagnostic output	OUT SD output	OUT diagnostic output 1
Pin 6	X2 Safety input 2	X2 Safety input 2	OUT 3 diagnostic output 3
Pin 7	Y2 Safety output 2	Y2 Safety output 2	Y2 Safety output 2
Pin 8	IN (do not use)	IN SD input	IN (do not use)
Pin 9	spare	spare	spare

Suffix	24V	24V	X1	X2	IN
-SK					
-CC	AZ 200.-.-1P2P				
	GND		Y1	Y2	OUT

Suffix	24V	24V	X1	X2	IN
	AZ 200.-.-SD2P				
	GND		Y1	Y2	OUT

Suffix	24V	24V	OUT2	OUT3	IN
	AZ 200.-.-3P2P				
	GND		Y1	Y2	OUT



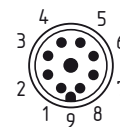

M12, 8-pole (suffix -ST2)

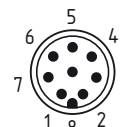



8.3 EC Declaration of conformity

	
<h2>EC Declaration of conformity</h2>	
Translation of the original declaration of conformity valid as of December 29, 2009	K.A. Schmersal GmbH Industrielle Sicherheitssysteme Möddinghofe 30 • 42279 Wuppertal Germany Internet: www.schmersal.com
We hereby certify that the hereafter described safety components both in its basic design and construction conforms to the applicable European Directives.	
<b>Name of the safety component:</b>	AZ 200
<b>Description of the safety component:</b>	Safety switch for safety functions
<b>Harmonised EC-Directives:</b>	2006/42/EC EC-Machinery Directive 2004/108/EC EMC-Directive
<b>Person authorized for the compilation of the technical documentation:</b>	Ulrich Loss Möddinghofe 30 42279 Wuppertal
<b>Notified body, which approved the full quality assurance system, referred to in Appendix X, 2006/42/EC:</b>	TÜV Rheinland Industrie Service GmbH Alboinstr. 56 12103 Berlin ID n°: 0035
<b>Place and date of issue:</b>	Wuppertal, December 10, 2009
AZ 200-B-EN	
	Authorised signature Heinz Schmersal Managing Director



**Note**

The currently valid declaration of conformity can be downloaded from the internet at [www.schmersal.net](http://www.schmersal.net).



**K. A. Schmersal GmbH**  
**Industrielle Sicherheitssysteme**  
Möddinghofe 30, D - 42279 Wuppertal  
Postfach 24 02 63, D - 42232 Wuppertal

Telefon +49 - (0)2 02 - 64 74 - 0  
Telefax +49 - (0)2 02 - 64 74 - 1 00  
E-Mail: [info@schmersal.com](mailto:info@schmersal.com)  
Internet: <http://www.schmersal.com>