



EN Operating instructions.pages 1 to 12
Translation of the original operating instructions

8 Disassembly and disposal
8.1 Disassembly.8
8.2 Disposal8

9 Appendix
9.1 Wiring examples9
9.2 Wiring configuration and connector accessories10

10 Declaration of conformity
10.1 EC Declaration of conformity.11

Content

1 About this document
1.1 Function1
1.2 Target group: authorised qualified personnel.1
1.3 Explanation of the symbols used1
1.4 Appropriate use1
1.5 General safety instructions2
1.6 Warning about misuse2
1.7 Exclusion of liability2

2 Product description
2.1 Ordering code2
2.2 Special versions2
2.3 Comprehensive quality insurance to 2006/42/EC2
2.4 Destination and use2
2.5 Technical data2
2.6 Safety classification3

3 Mounting
3.1 General mounting instructions3
3.2 Dimensions4

4 Electrical connection
4.1 General information for electrical connection.5

5 Operating principles, coding and latching force adjustment
5.1 Mode of operation of the safety outputs.5
5.2 Actuator teaching / actuator detection6
5.3 Latching force adjustment6

6 Diagnostic function
6.1 Diagnostic-LEDs6
6.2 Safety switch with conventional diagnostic output.6
6.3 Safety switch with serial diagnostic function SD7

7 Set-up and maintenance
7.1 Functional testing.8
7.2 Maintenance8

1. About this document

1.1 Function
This operating instructions manual provides all the information you need for the mounting, set-up and commissioning to ensure the safe operation and disassembly of the safety switchgear. The operating instructions must be available in a legible condition and a complete version in the vicinity of the device.

1.2 Target group: authorised qualified personnel
All operations described in this operating instructions manual must be carried out by trained specialist personnel, authorised by the plant operator only.

Please make sure that you have read and understood these operating instructions and that you know all applicable legislations regarding occupational safety and accident prevention prior to installation and putting the component into operation.

The machine builder must carefully select the harmonised standards to be complied with as well as other technical specifications for the selection, mounting and integration of the components.

1.3 Explanation of the symbols used

 **Information, hint, note:**
This symbol is used for identifying useful additional information.

 **Caution:** Failure to comply with this warning notice could lead to failures or malfunctions.
Warning: Failure to comply with this warning notice could lead to physical injury and/or damage to the machine.

1.4 Appropriate use
The products described in these operating instructions are developed to execute safety-related functions as part of an entire plant or machine. It is the responsibility of the manufacturer of a machine or plant to ensure the correct functionality of the entire machinery or plant.

The safety switchgear must be exclusively used in accordance with the versions listed below or for the applications authorised by the manufacturer. Detailed information regarding the range of applications can be found in the chapter "Product description".

1.5 General safety instructions

The user must observe the safety instructions in this operating instructions manual, the country-specific installation standards as well as all prevailing safety regulations and accident prevention rules.



Further technical information can be found in the Schmersal catalogues or in the online catalogue on the Internet: www.schmersal.net.

The information contained in this operating instructions manual is provided without liability and is subject to technical modifications.

There are no residual risks, provided that the safety instructions as well as the instructions regarding mounting, commissioning, operation and maintenance are observed.

1.6 Warning about misuse



In case of inadequate or improper use or manipulations of the safety switchgear, personal hazards or damages to machinery or plant components cannot be excluded. The relevant requirements of the standard EN 1088 must be observed.

1.7 Exclusion of liability

We shall accept no liability for damages and malfunctions resulting from defective mounting or failure to comply with this operating instructions manual. The manufacturer shall accept no liability for damages resulting from the use of unauthorised spare parts or accessories.

For safety reasons, invasive work on the device as well as arbitrary repairs, conversions and modifications to the device are strictly forbidden; the manufacturer shall accept no liability for damages resulting from such invasive work, arbitrary repairs, conversions and/or modifications to the device.

2. Product description

2.1 Ordering code

AZ300-①-②-③

No.	Option	Description
①		Standard coding
	I1	Individual coding
	I2	Individual coding, re-teaching enabled
②	ST	Connector plug M12, 8-pole
③	1P2P	1 p-type diagnostic output and 2 p-type safety outputs
	SD2P	serial diagnostic output and 2 p-type safety outputs

2.2 Special versions

For special versions, which are not listed in the order code below 2.1, these specifications apply accordingly, provided that they correspond to the standard version.

2.3 Comprehensive quality insurance to 2006/42/EC

Schmersal is a certified company to appendix X of the Machinery Directive. As a result, Schmersal is entitled to autonomously conduct the conformity assessment procedure for the products listed in Appendix IV of the MD without involving a notified body. In addition to that, the EC prototype test certificates are available upon request or can be downloaded from the Internet at www.schmersal.com.

2.4 Destination and use

The AZ300 with non-contact electronic safety sensors is designed for application in safety circuits and is used for monitoring the position of movable safety guards.

The safety function consists of safely switching off the safety outputs when the safety guard is opened and maintaining the safe switched off condition of the safety outputs for as long as the safety guard is open.

Series-wiring

Series-wiring can be set up. The response and risk times are not altered by wiring in series. The number of components is only limited by the external cable protection according to the technical data and the line loss. Series-wiring of up to 31 AZ300 ... SD components with serial diagnostics is possible. In devices with the serial diagnostics function (ordering suffix -SD), the serial diagnostics connections are wired in series and connected to a SD-Gateway for evaluation purposes. Wiring examples for series-wiring, refer to appendix



The user must evaluate and design the safety chain in accordance with the relevant standards and the required safety level. If multiple safety sensors are involved in the same safety function, the PFH values of the individual components must be added.



The entire concept of the control system, in which the safety component is integrated, must be validated to the relevant standards.

2.5 Technical data

Standards:	EN 60947-5-1, IEC 60947-5-3, IEC 61508, EN ISO 13849-1
Series-wiring:	Unlimited number of components, please observe external cable protection, max. 31 components in case of serial diagnostics
Length of the sensor chain:	max. 200 m
Working principle:	RFID
Material of the housings:	glass-fibre reinforced thermoplastic, ventilated
Response time:	120 ms
Duration of risk:	< 200 ms
Time to readiness:	≤ 5 s
Recommended actuator:	AZ/AZM300-B1.1
Switch distances:	
Rated switching distance S_n :	2 mm
assured switching distance s_{a0} :	1 mm
assured switch-off distance s_{a1} :	20 mm
Mechanical data:	
Execution of the electrical connection:	M12 connector plug, 8 poles, A-coded
Mechanical life:	≥ 1,000,000 operations
- For safety guards 5 kg and actuating speed 0.5 m/s:	≥ 50,000 operations
Angular misalignment between safety switch and actuator:	≤ 2°
Fixing screws:	2x M6
Max. tightening torque:	1.8 Nm
Resistance to shock:	30 g / 11 ms
Resistance to vibration:	10 ... 150 Hz, amplitude 0.35 mm
Latching force:	25 N / 50 N
Ambient conditions:	
Ambient temperature:	
- Min. ambient temperature:	0°C
- Max. ambient temperature:	+60°C
Storage and transport temperature:	
- Min. storage and transport temperature:	-10°C
- Max. storage and transport temperature:	+90°C
Protection class:	IP66, IP67, to IEC/EN 60529, IP69K to DIN 40050-9
Protection class:	II
Insulation values to IEC/EN 60664-1:	
- Rated impulse withstand voltage U_{imp} :	0.8 kV
- Overvoltage category:	III
- Degree of pollution:	3

Electrical data:	
Supply voltage U_B :	24 VDC (-15 % / +10 %) stabilised PELV units
Switching frequency:	0.5 Hz
Rated insulation voltage U_i :	32 VDC
Power consumption without load:	0.1 A
Required rated short-circuit current:	100 A
External Device fuse rating:	2 A (T)
Electrical data - Safety inputs:	
Safety inputs:	X1 and X2
Switching thresholds:	- 3 V ... 5 V (Low), 15 V ... 30 V (High)
Power consumption:	≤ 5 mA / 24 V
Electrical data - Safety outputs:	
Safety outputs:	Y1 and Y2
Switching elements:	p-type, short-circuit proof
Utilisation category:	AC-12, DC-13
Rated operating voltage U_o :	0 V ... 4 V under supply voltage UB
Rated operating current I_o :	0.25 A
Leakage current I_r :	≤ 0.5 mA
Test impulse width:	< 0.5 ms
Test frequency:	1 Hz
Electrical data - Diagnostic output:	
Diagnostic output:	OUT
Switching element:	p-type, short-circuit proof
Utilisation category:	AC-12, DC-13
Rated operating voltage U_o :	0 V ... 4 V under Supply voltage UB
Rated operating current I_o :	0.05 A
LED status display:	
green LED:	Supply voltage
yellow LED:	device condition
red LED:	Internal device error
2.6 Safety classification	
Standards:	EN ISO 13849-1, IEC 61508
PL:	e
Control Category:	4
PFH value:	$5.2 \times 10^{-10} / h$
SIL:	3
Service life:	20 years

3. Mounting

3.1 General mounting instructions

For fixing the safety switch, the device is provided with two mounting holes for M6 screws.



Please observe the remarks of the standards EN ISO 12100, EN 953 and EN 1088.



The safety switch can be used as an end stop. Dependant upon the door weight and the actuating speed, the mechanical life could be reduced.

Any mounting position. The system must only be operated with an angle of $\leq 2^\circ$ between the safety switch and the actuator. When mounting the solenoid interlock onto metallic surfaces, a galvanic connection must be realised between the mounting surface and fixing point "A".

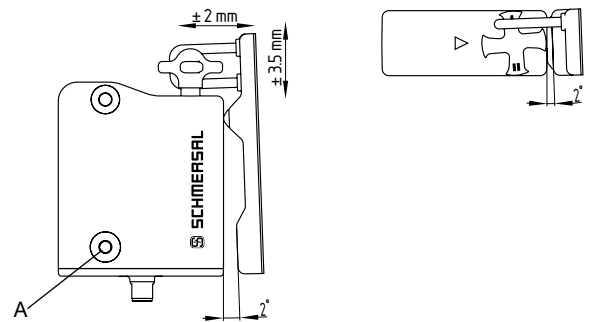

Provide for a sufficient insertion of the actuator into the rotary handle

Correct

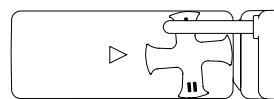

False

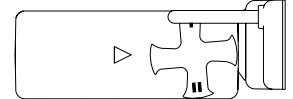

The safety component and the actuator must be permanently fitted to the safety guards and protected against displacement by suitable measures (tamperproof screws, gluing, drilling, pinning).

Mounting of the safety switch and the actuator

Refer to the mounting instructions manual for the corresponding actuator.

To avoid any interference inherent to this kind of system and any reduction of the switching distances, please observe the following guidelines:

- The presence of metal chips in the vicinity of the solenoid interlock is liable to modify the switching distance.
- Keep away from metal chips.
- Minimum distance between two safety switches: 250 mm

Actuating directions

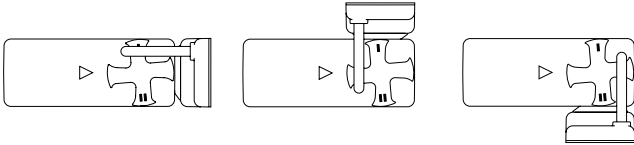

Mounting with mounting plate

For doors, which close flush with the door frame, the optional mounting plate MP-AZ/AZM300-1 can be used.

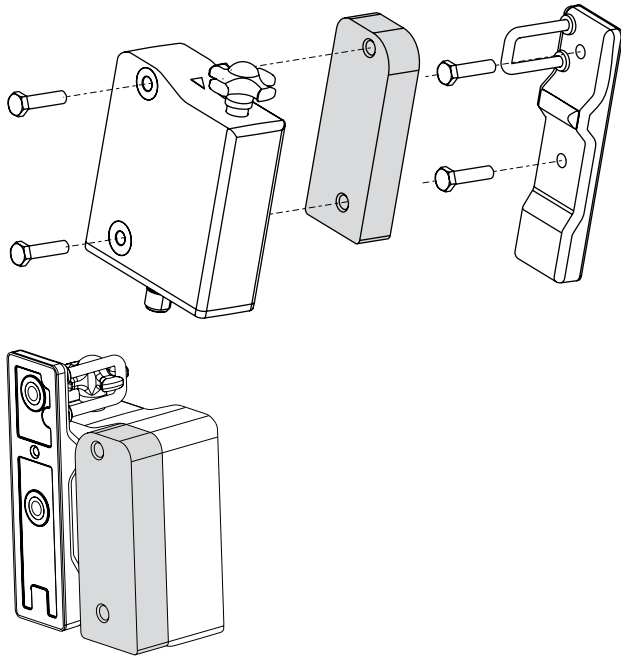

3.2 Dimensions

All measurements in mm.

AZ300

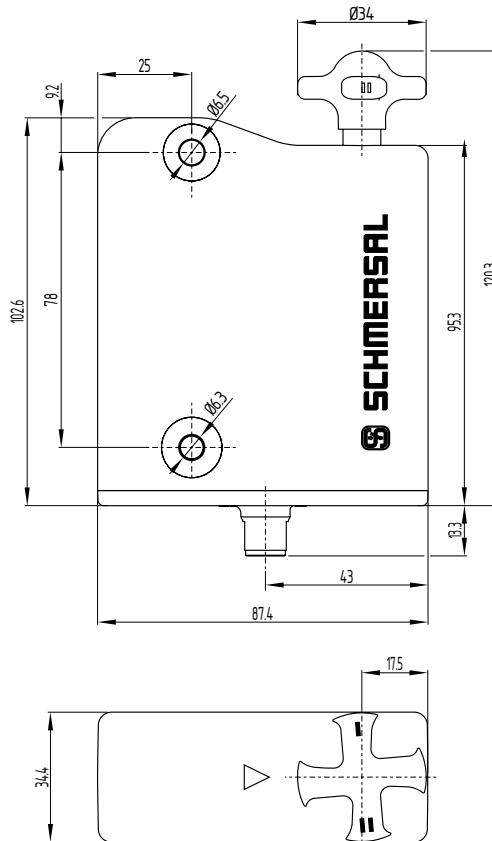

AZ/AZM300-B1

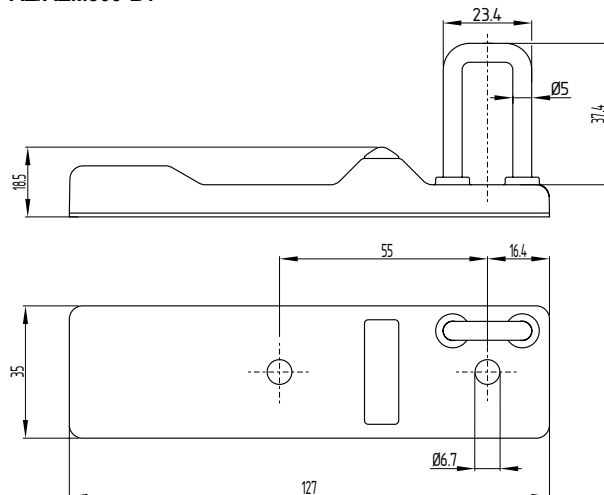

MP-AZ/AZM300-1

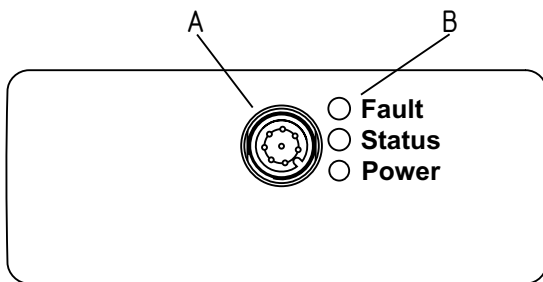
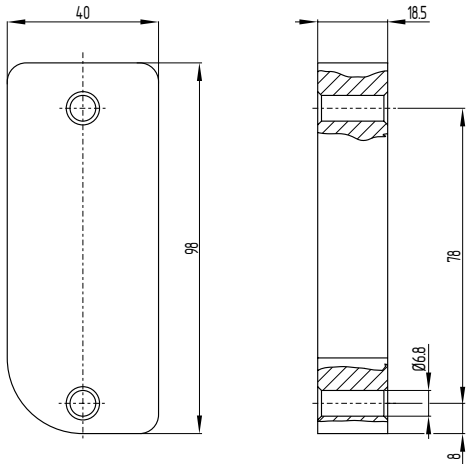

Legend

A: connector plug M12, 8-pole
B: LED display

4. Electrical connection

4.1 General information for electrical connection



The electrical connection may only be carried out by authorised personnel in a de-energised condition.

The voltage inputs A1, X1, X2 and IN must have a protection against permanent overvoltage. The use of PELV supply units according to IEC 60204-1 is recommended.

The safety outputs can be integrated in the safety circuit of the control system.

Requirements for the connected safety-monitoring module:

- Dual-channel safety input, suitable for p-type semi-conductor outputs
- Test function

The safety switches cyclically switch off their safety outputs to test them. The safety-monitoring module therefore does not need to be equipped with a cross-wire short detection. The switch-off times must be tolerated by the safety-monitoring module. The switch-off time of the safety switch is additionally extended depending on the cable length and the capacity of the cable used. The typical switch-off time with a connecting cable of 30m is 250 µs.



Information for the selection of suitable safety-monitoring modules can be found in the Schmersal catalogues or in the online catalogue on the Internet: www.schmersal.net.

Cable design in case of serial diagnostics



When wiring SD devices, please observe the voltage drop on the cables and the current carrying capacity of the individual components.

The wiring capacitance of the connecting cable of the safety switch must not exceed 50 nF. Depending on the strand structure, normal unshielded 30 m long LIYY 0.25 mm² to 1.5 mm² cables have a wiring capacitance of approx. 3 ... 7 nF.

ment

5.1 Mode of operation of the safety outputs

The opening of the safety guard causes the safety outputs to be disabled within the reaction time.

If the safety outputs are already enabled, any error that does not immediately affect the functionality of the safety switch (e.g. too high an ambient temperature, interference potential at the safety outputs, cross-wire short) will lead to a warning message, the disabling of the diagnostic output and the delayed shutdown of the safety outputs. The safety outputs are disabled, when the error warning is active for 30 minutes. The combination of the signals "diagnostic output disabled" and "safety outputs still enabled" can be used to bring the machine to a controlled standstill. After elimination of the error, the error message is reset by opening the corresponding safety guard. For devices featuring serial diagnostics, the error can be reset by setting/deleting a bit in the request telegram.

5.2 Actuator teaching / actuator detection

Safety switches with standard coding are ready to use upon delivery.

Individually coded safety switches and actuators will require the following "teach-in" procedure:

1. Switch the safety switch's voltage supply off and back on.
2. Introduce the actuator in the detection range. The teach-in procedure is signalled at the safety switch, green LED off, red LED on, yellow LED flashes (1 Hz).
3. After 10 seconds, brief cyclic flashes (3 Hz) request the switch-off of the operating voltage of the safety switch. (If the voltage is not switched off within 5 minutes, the safety switch cancels the "teach-in" procedure and signals a false actuator by 5 red flashes).
4. After the operating voltage is switched back on, the actuator must be detected once more in order to activate the taught actuator code. In this way, the activated code is definitively saved!

For ordering suffix -I1, the thus executed allocation of safety switchgear and actuator is irreversible.

For ordering suffix -I2, the "teach-in" procedure for a new actuator can be repeated an unlimited number of times. When a new actuator is taught, the code, which was applicable until that moment, becomes invalid. Subsequent to that, an enabling inhibit will be active for ten minutes, thus providing for an increased protection against tampering. The green LED will flash until the expiration of the time of the enabling inhibit and the detection of the new actuator. In case of power failure during the lapse of time, the 10-minute tampering protection time will restart.

5.3 Latching force adjustment

In order to enable trouble-free functionality of the device, the rotary handle must be in position I or II when the safety guard is open.

The latching force is changed by turning the rotary handle by 180°.

In position I, the latching force is approx. 25 N.

In position II, the latching force is approx. 50 N.

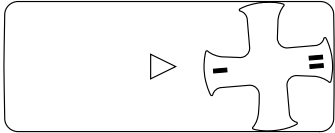

6. Diagnostic function

6.1 Diagnostic-LEDs

The safety switch signals the operating condition, as well as errors through 3-colour LED's.

green (Power) Supply voltage on

yellow (Status) Operating condition

red (Fault) Fault (see Table: flash codes of the red diagnostic LED)

6.2 Safety switch with conventional diagnostic output

The short-circuit proof diagnostic output OUT can be used for central visualisation or control functions, e.g. in a PLC.

The diagnostic output is not a safety-related output!

Error

Errors, which no longer guarantee the function of the safety switch (internal errors) cause the safety outputs to be disabled within the risk time. Any error that does not immediately affect the safe functionality of the AZ300 safety switch (e.g. cross-wire short, ambient temperature too high, interference potential at a safety output) will lead to the delayed shut-down (refer to Table 2). After elimination of the error, the error message is reset by opening the corresponding safety guard.

Error warning

A fault has occurred, which causes the safety outputs to be disabled after 30 minutes (LED "error" flashes, see Table 2). The safety outputs initially remain enabled. This enables the shutdown of the process in a controlled manner. An error warning is deleted when the error cause is eliminated.

Diagnostic information

Table 1: Diagnostic information of the safety switchgear

The safety switch signals the operational state as well as errors through three coloured LED's installed on the device.

System condition	LED			Safety outputs Y1, Y2	Diagnostic output OUT
	green	red	yellow		
Safety guard open	On	Off	Off	0 V	0 V
Safety guard closed	On	Off	On	24 V	24 V
Error warning ¹⁾	On	Flashes ²⁾	Off	24 V ¹⁾	0 V
Error	On	Flashes ²⁾	Off	0 V	0 V
Additionally for variant I1/I2:					
Teach-in procedure actuator started	Off	On	Flashes	0 V	0 V
Only I2: teach-in procedure actuator (release block)	Flashes	Off	Off	0 V	0 V

1) after 30 min: disabling due to fault

2) refer to flash code

Table 2: Error messages / flash codes red diagnostic LED

Flash codes (red)	Designation	Autonomous switch-off after	Error cause
1 flash pulse	Error (warning) at output Y1	30 min	Fault in output test or voltage at output Y1, although the output is disabled.
2 flash pulses	Error (warning) at output Y2	30 min	Fault in output test or voltage at output Y2, although the output is disabled.
3 flash pulses	Error (warning) cross-wire short	30 min	Cross-wire short between the output cables or fault at both outputs
4 flash pulses	Error (warning) temperature too high	30 min	The temperature measurement reveals an internal temperature that is too high
5 flash pulses	Actuator fault	0 min	Incorrect or defective actuator, bracket broken
6 flash pulses	Fault rotary handle	0 min	Rotary handle not in authorised intermediate position
Continuous red signal	Internal error	0 min	

6.3 Safety switch with serial diagnostic function SD

Safety switches with serial diagnostic cable have a serial input and output cable instead of the conventional diagnostic output. If safety switches are wired in series, the diagnostic data is transmitted through the series-wiring of the inputs and outputs.

Max. 31 safety switches can be wired in series. For the evaluation of the serial diagnostics line either the PROFIBUS-Gateway SD-I-DP-V0-2 or the Universal-Gateway SD-I-U-... are used. This serial diagnostic interface is integrated as a slave in an existing field bus system. In this way, the diagnostic signals can be evaluated by means of a PLC.

The response data and the diagnostic data are automatically and permanently written in an input byte of the PLC for each safety switch in the series-wired chain. The request data for each safety switch is transmitted to the component through an output byte of the PLC. In case of a communication error between the field bus gateway and the safety switch, the switching condition of the safety switch is maintained.

Error

A fault has occurred, which causes the safety outputs to be disabled. The fault is reset, when the cause is eliminated and bit 7 of the request byte changes from 1 to 0 or the safety guard is opened. Faults at the safety outputs are only deleted upon the next release, as the fault rectification cannot be detected sooner.



If more than one fault is detected at the safety outputs, the AZ300 will be electronically locked and a normal fault reset will no longer be possible. To reset this type of interlocking, the AZ300, must be isolated from the power supply after elimination of the error causes.

Error warning

A fault has occurred, which causes the safety outputs to be disabled after 30 minutes. The safety outputs initially remain enabled. This enables the shutdown of the process in a controlled manner. An error warning is deleted when the error cause is eliminated.

Diagnostic error (warning)

If an error (warning) is signalled in the response byte, detailed fault information can be read out.

Accessories for the series-wiring

To provide for a comfortable wiring and series-wiring of SD components, the connectors and the SD-2V-F-SK SD junction boxes (variant for the field in closed enclosure) and SD-2V-S-SK (variant for DIN rail mounting in the control cabinet) are available.



When wiring SD devices, please observe the voltage drop on the cables and the current carrying capacity of the individual components.

Table 3: I/O data and diagnostic data

Bit n°	Request byte	Response byte	Diagnostic error warning	Diagnostic error
Bit 0:	---	Safety output activated	Error output Y1	Error output Y1
Bit 1:	---	Actuator detected	Error output Y2	Error output Y2
Bit 2:	---	---	Cross-wire short	Cross-wire short
Bit 3:	---	---	Temperature too high	Temperature too high
Bit 4:	---	Input condition X1 and X2	---	Incorrect or defective actuator, bracket broken
Bit 5:	---	Coding recognised	Internal device error	Internal device error
Bit 6:	---	Error warning ¹⁾	Communication error between the field bus Gateway and the safety switchgear	---
Bit 7:	Error reset	Error (enabling path switched off)	Rotary handle not in authorised intermediate position	Rotary handle not in authorised intermediate position

1) after 30 min -> fault

The described condition is reached, when Bit = 1

7. Set-up and maintenance

7.1 Functional testing

The safety function of the safety components must be tested. The following conditions must be previously checked and met:

1. Check max. axial misalignment of actuator and safety switch
2. Check max. angular misalignment (see "Mounting" part)
3. Check the integrity of the cable entry and connections.
4. Check the switch enclosure for damage.
5. Remove particles of dust and soiling.

7.2 Maintenance

In the case of correct installation and adequate use, the safety switchgear features maintenance-free functionality. A regular visual inspection and functional test, including the following steps, is recommended:

- Check the fixing of the safety switch and the actuator
- Check max. axial misalignment of actuator and safety switch
- Check max. angular misalignment (see "Mounting" part)
- Check the integrity of the cable entry and connections.
- Check the switch enclosure for damages
- Remove soiling

Damaged or defective components must be replaced.

8. Disassembly and disposal

8.1 Disassembly

The safety switchgear must be disassembled in a de-energised condition only.

8.2 Disposal

The safety switchgear must be disposed of in an appropriate manner in accordance with the national prescriptions and legislations.

9. Appendix

9.1 Wiring examples

The application examples shown are suggestions. They however do not release the user from carefully checking whether the switchgear and its set-up are suitable for the individual application.

Wiring example 1: Series-wiring of the AZ300 with conventional diagnostic output

The voltage is supplied at both safety inputs of the terminal safety component of the chain (considered from the safety-monitoring module). The safety outputs of the first safety component are wired to the safety-monitoring module.

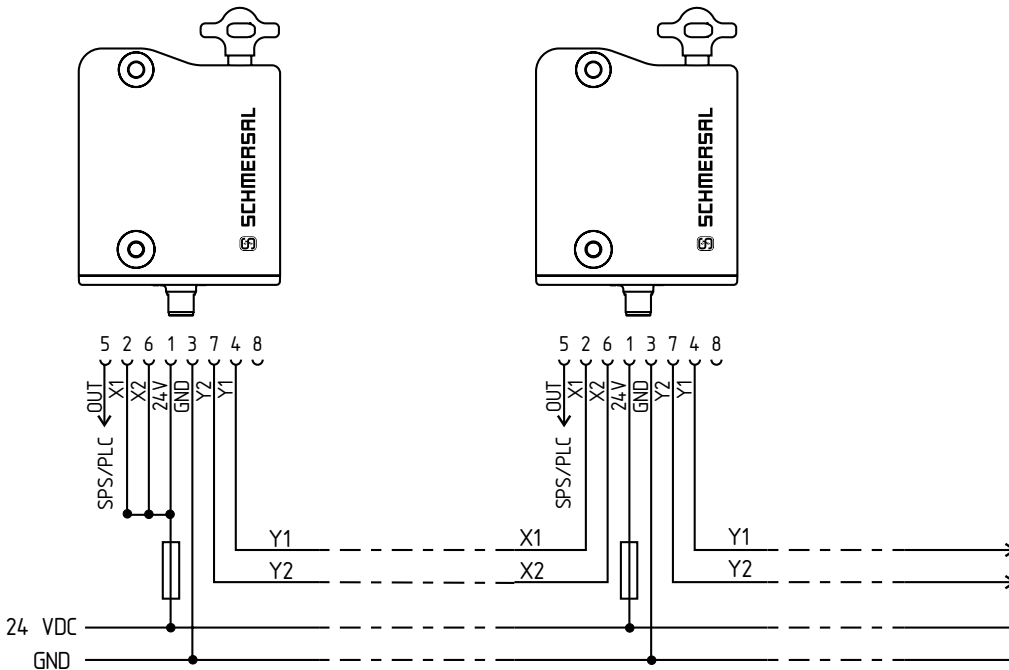

Y1 and Y2 = Safety outputs → Safety monitoring module

Wiring example 2: Series-wiring of the AZ300 with serial diagnostic function

The safety outputs of the first safety component are wired to the safety-monitoring module. The serial Diagnostic Gateway is connected to the serial diagnostic input of the first safety component.

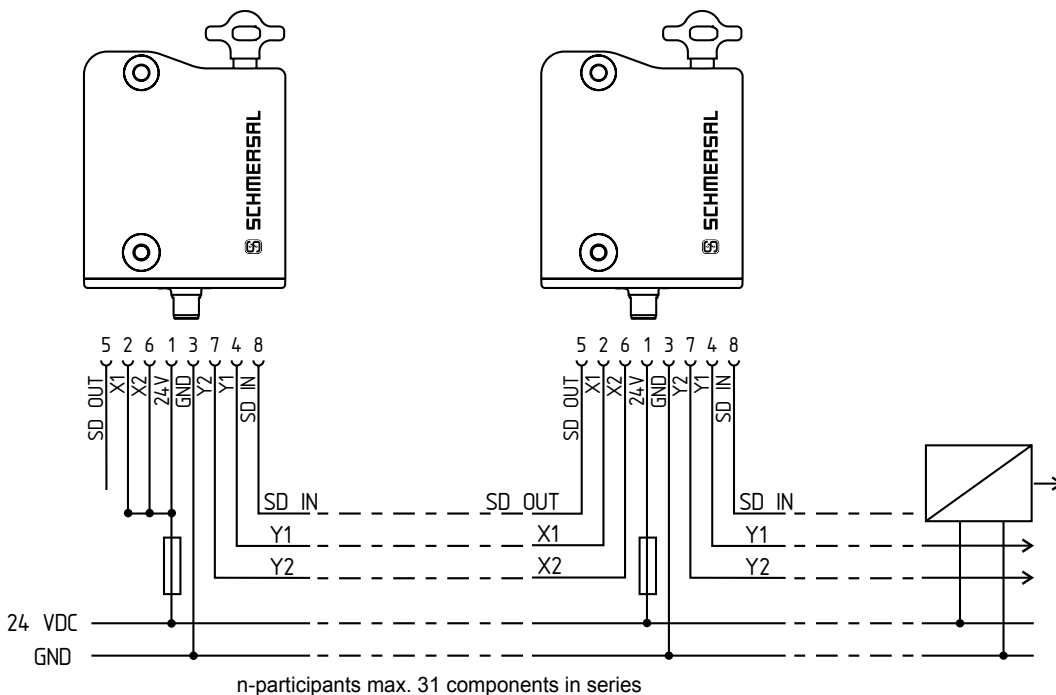

n-participants max. 31 components in series

Y1 and Y2 = Safety outputs → Safety monitoring module

SD-IN → Gateway → Field bus

9.2 Wiring configuration and connector accessories

Function safety switchgear		Pin configuration of the connector	Colour code or conductor numbering of the below-mentioned Schmersal connectors		Possible colour code of other commercially available connectors		
with conventional diagnostic output	with serial diagnostic function				to EN 60947-5-2: 2007	DIN 47100	
A1	U _e		1	BN	1	BN	WH
X1	Safety input 1		2	WH	2	WH	BN
A2	GND		3	BU	3	BU	GN
Y1	Safety output 1		4	BK	4	BK	YE
OUT	Diagnostic output	SD output	5	GY	5	GY	GY
X2	Safety input 2		6	VT	6	PK	PK
Y2	Safety output 2		7	RD	7	VT	BU
IN	without function	SD input	8	PK	8	or	RD

Connector plug M12, 8-pole



Connecting cables with female connector IP67, M12, 8-pole - 8 x 0.23 mm²

Cable length	Ordering code
2.5 m	101209963
5.0 m	101209964
10.0 m	101209960

Connecting cables with female connector IP69K, M12, 8-pole - 8 x 0.21 mm²

Cable length	Ordering code
5.0 m	101210560
5.0 m	101210561 (angled)

10. Declaration of conformity

10.1 EC Declaration of conformity

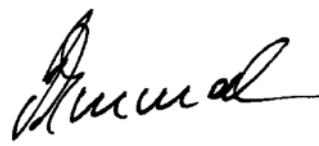
	
<h2>EC Declaration of conformity</h2>	
Translation of the original Declaration of Conformity	K.A. Schmersal GmbH & Co. KG Industrielle Sicherheitssysteme Mödinghofe 30, 42279 Wuppertal Germany Internet: www.schmersal.com
We hereby certify that the hereafter described safety components both in its basic design and construction conform to the applicable European Directives.	
Name of the safety component:	AZ300
Description of the safety component:	Safety Switch for safety functions
Relevant EC-Directives:	2006/42/EC - EC-Machinery Directive 2004/108/EC - EMC-Directive 1999/5/EC - R&TTE-Directive
Person authorized for the compilation of the technical documentation:	Oliver Wacker Mödinghofe 30 42279 Wuppertal
Notified body, which approved the full quality assurance system, referred to in Appendix X, 2006/42/EC:	TÜV Rheinland Industrie Service GmbH Alboinstr. 56 12103 Berlin ID n°: 0035
Place and date of issue:	Wuppertal, April 20, 2013
AZ300-A-EN	
	Authorised signature Philip Schmersal Managing Director



The currently valid declaration of conformity can be downloaded from the internet at www.schmersal.net.



K. A. Schmersal GmbH & Co. KG
Industrielle Sicherheitssysteme
Möddinghofe 30, D - 42279 Wuppertal
Postfach 24 02 63, D - 42232 Wuppertal

Phone: +49 - (0)2 02 - 64 74 - 0
Telefax +49 - (0)2 02 - 64 74 - 1 00
E-Mail: info@schmersal.com
Internet: <http://www.schmersal.com>