



EN Operating instructions. pages 1 to 10
Translation of the original operating instructions

Content

1 About this document

1.1 Function 1

1.2 Target group: authorised qualified personnel. 1

1.3 Explanation of the symbols used 1

1.4 General safety instructions 1

1.5 Warning about misuse 1

1.6 Exclusion of liability 1

2 Product description

2.1 Ordering code 2

2.2 Special versions. 2

2.3 Destination and use 2

3 Mounting

3.1 General mounting instructions 2

3.2 Representation of installation options 2

3.3 Dimensions 3

3.4 Sequence of the steps 5

4 Appendix

4.1 Set-up checklist 9

1. About this document

1.1 Function

This operating instructions manual provides all the information you need for the mounting, set-up and commissioning to ensure the safe operation and disassembly of the the product. he operating instructions must be available in a legible condition and a complete version in the vicinity of the device.

1.2 Target group: authorised qualified personnel

All operations described in this operating instructions manual must be carried out by trained specialist personnel, authorised by the plant operator only.

Please make sure that you have read and understood these operating instructions and that you know all applicable legislations regarding occupational safety and accident prevention prior to installation and putting the component into operation.

The machine builder must carefully select the harmonised standards to be complied with as well as other technical specifications for the selection, mounting and integration of the components.

1.3 Explanation of the symbols used



Information, hint, note:
This symbol is used for identifying useful additional information.



Caution: Failure to comply with this warning notice could lead to failures or malfunctions.
Warning: Failure to comply with this warning notice could lead to physical injury and/or damage to the machine.

1.4 General safety instructions

The user must observe the safety instructions in this operating instructions manual, the country-specific installation standards as well as all prevailing safety regulations and accident prevention rules.



Further technical information can be found in the Schmersal catalogues or in the online catalogue on the Internet: www.schmersal.net.

The information contained in this operating instructions manual is provided without liability and is subject to technical modifications.

There are no residual risks, provided that the safety instructions as well as the instructions regarding mounting, commissioning, operation and maintenance are observed.

1.5 Warning about misuse



In case of inadequate or improper use or manipulations of the component, personal hazards or damage to machinery or plant components cannot be excluded. The relevant requirements of the standard EN ISO 14119 must be observed.

1.6 Exclusion of liability

We shall accept no liability for damages and malfunctions resulting from defective mounting or failure to comply with this operating instructions manual. The manufacturer shall accept no liability for damages resulting from the use of unauthorised spare parts or accessories.

For safety reasons, invasive work on the device as well as arbitrary repairs, conversions and modifications to the device are strictly forbidden; the manufacturer shall accept no liability for damages resulting from such invasive work, arbitrary repairs, conversions and/or modifications to the device.

x.000 / 10.2015 / v.A. - 103008978-EN / B / 2015-10-23 / AE-Nr. 5308

2. Product description

2.1 Ordering code

This operating instructions manual applies to the following types:

AZ/AZM 200-B30-①T②③④-⑤

No.	Option	Description
①	L	Door hinge on left-hand side
	R	Door hinge on right-hand side
②	A	For mounting outside
	I	For mounting inside
③	G1	With doorhandle
	G2	With rotating knob
	P1	With emergency exit
	P20	With emergency exit metal *
④	P25	With emergency exit inset handle *
	P30/P31	With locking rod *
	SZ	Without lockout tag *
⑤	SZ	With lockout tag *

* Only for mounting outside



Only if the information described in this operating instructions manual are realised correctly, the safety function and therefore the compliance of the entire system with the Machinery Directive is maintained.

2.2 Special versions

For special versions, which are not listed in the order code below 2.1, these specifications apply accordingly, provided that they correspond to the standard version.

2.3 Destination and use

In conjunction with the solenoid interlock or switch, the actuator unit is suitable for hinged and sliding safety guards. The safety guard can be opened and closed from outside by turning the door-handle.



Holding force F_{max}
 - mounting outside 2000 N
 - mounting inside 1000 N

The actuator is pulled into the actuator unit by a spring. The actuator unit with emergency exit is used to open the safety guard inside the hazardous area. By actuating the emergency exit, the safety guard can be opened from within the hazardous area without the need for unlocking the solenoid interlock. The safety guard cannot be locked from inside.

On accessible protective equipment, the lockout tag prevents persons from being inadvertently being trapped. When entering the hazardous area, each member of the operating or service team fixes a lock to the lockout tag to prevent the locking of the safety guard and therefore any inadvertent machine start.

Actuator unit play

- X = ± 1.5 mm
- Y = ± 5.0 mm
- Z = ± 1.0 mm

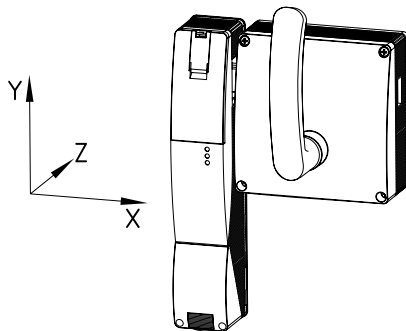

3. Mounting

3.1 General mounting instructions



The installation may only be carried out by authorised personnel.

Admissible mounting set-up

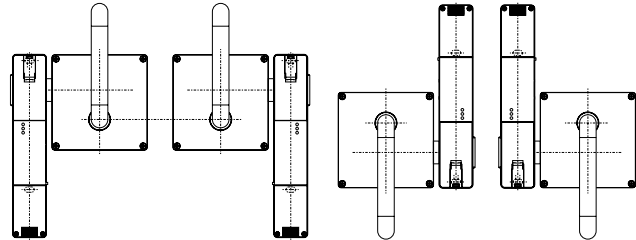

Inadmissible mounting set-up

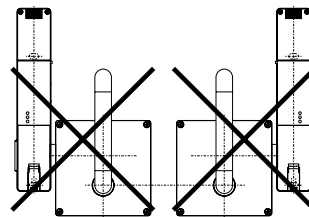

3.2 Representation of installation options

The actuators AZ/AZM 200-B30 are available for both outdoor use and indoor use.

For outdoor use, the safety switchgear AZ/AZM 200 is placed outside the hazardous area, for indoor use it is placed within the hazardous area.

		Mounting outside		Mounting inside	
With emergency exit	Right hinged door				
	Left hinged door				
Without emergency exit	Right hinged door				
	Left hinged door				



The minimum radius of the door when mounting outside is 400 mm, mounting inside 700 mm.

Assumptions:

- 40 mm Profile
- Distance between solenoid interlock and actuator unit 7.5 mm
- Use standard hinge for 40 mm profile

3.3 Dimensions

All measurements in mm.

Mounting outside

AZM 200 with actuator unit
mounting outside of the hazardous area

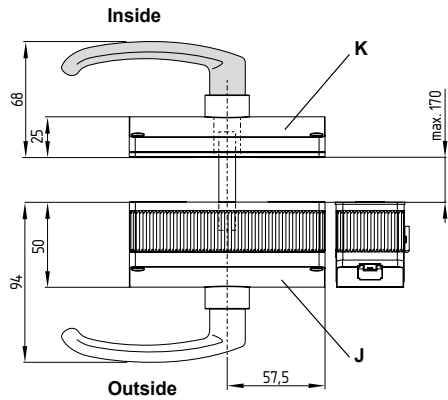
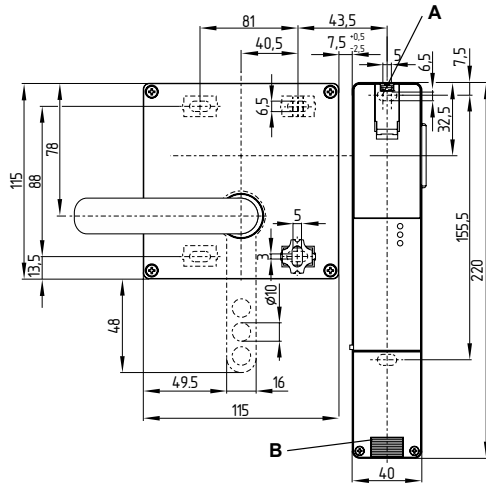

Interior view: Emergency exit P1

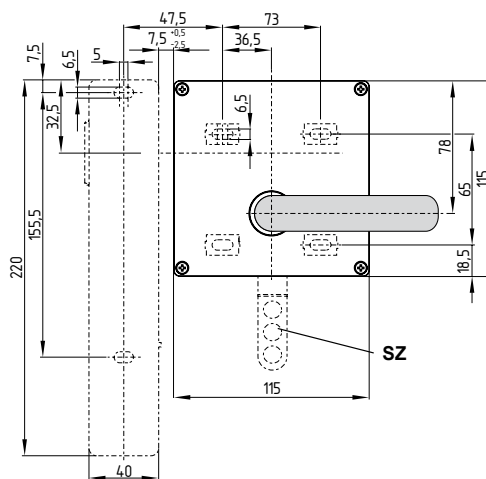

Mounting inside

AZM 200 with emergency exit P1
mounting inside of the hazardous area

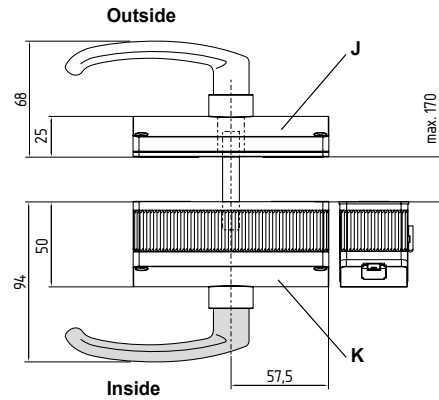
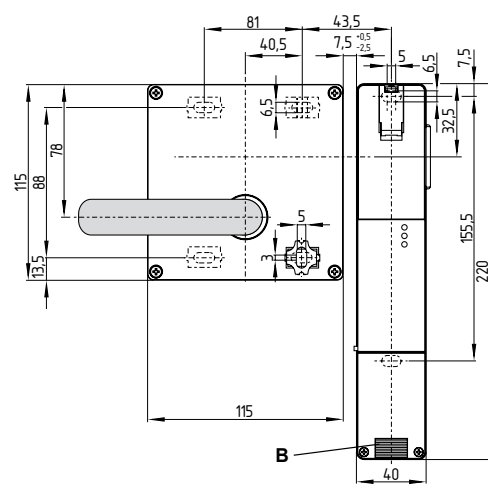

Exterior view: Actuator unit with door handle

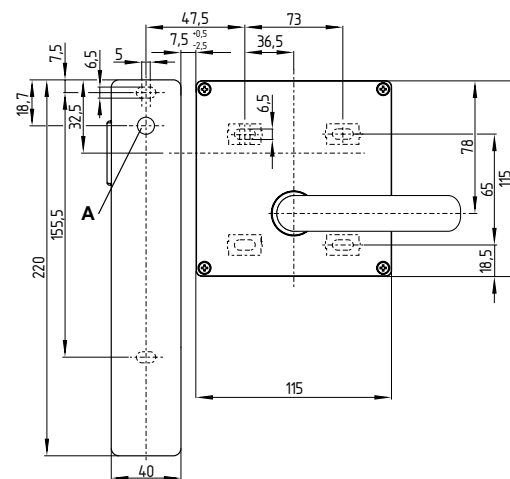

Key

- A = Manual release
- B = Cable entry M20 x 1.5
- J = Actuator unit with door-handle G1
- K = Emergency exit P1
- SZ = Lockout tag

Instead of the door handle G1 a rotating knob G2 can be optionally be used.

Rotating knob G2

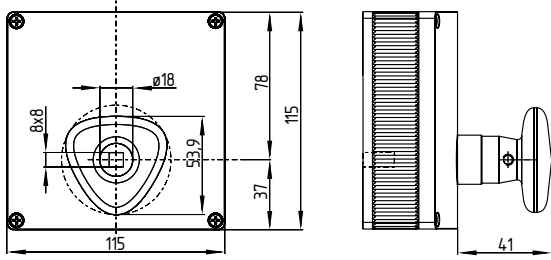

Instead of the emergency exit P1 the following emergency exits can be used for outdoor assembly.

Emergency exit (metal) P20

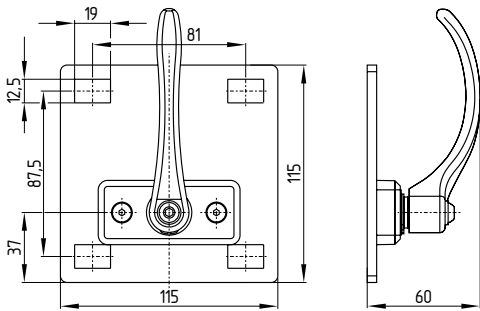

Emergency exit inset handle P25

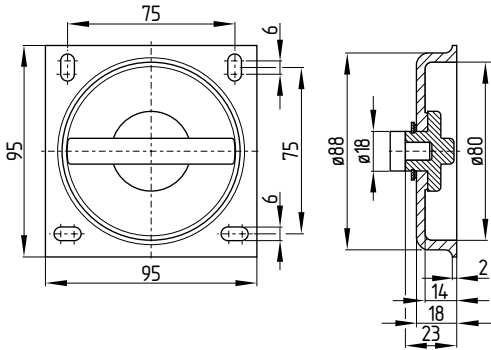

Accessories

The lockout tags SZ 200 and SZ 200-1 are optional as additional lockout tags for indoor and outdoor assembly are available.

Lockout tag SZ 200

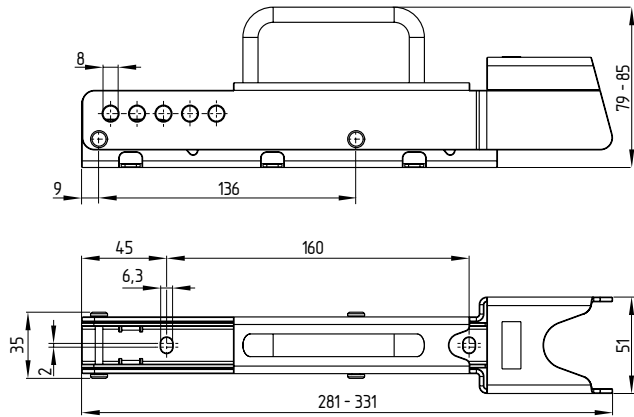

Lockout tag SZ 200-1

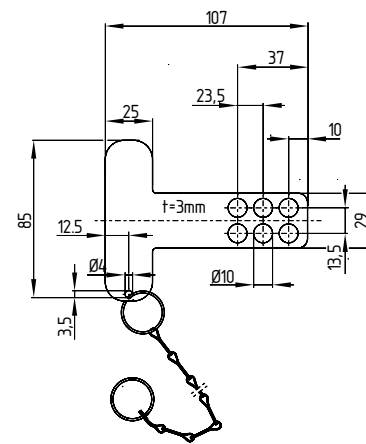

3.4 Sequence of the steps

The following work instructions are valid for both indoor and outdoor assembly. If there are any differences with the versions these are indicated with notes or additional sketches.

Step 1

To free mounting holes unscrew the cover C for the wiring compartment and open flap A for the manual release.

To be observed:

- For **mounting outside**: Actuation of the manual release (behind flap) by triangular key
- For **mounting inside**: Actuation of the manual release by triangular key at the back

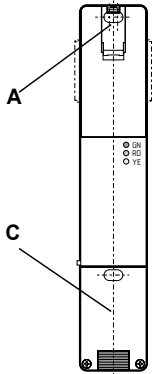

Step 2

Enclosure of the safety switchgear AZ/AZM 200 must be flush-mounted with the doorpost.

- For **mounting inside**: An additional access hole **Z** $\geq \varnothing 10$ mm is necessary for the manual release to allow external access.

To be observed:

- Screws DIN 912-M6
- Max. torque for solenoid interlock = 8 Nm, cover screw = 0.7...1 Nm (Torx T10)
- Wall thickness of the device 19 mm
- Washers DIN 125-6.4 (included in delivery)
- For applications with strong vibrations, please observe the screws are correctly secured.

Mounting outside

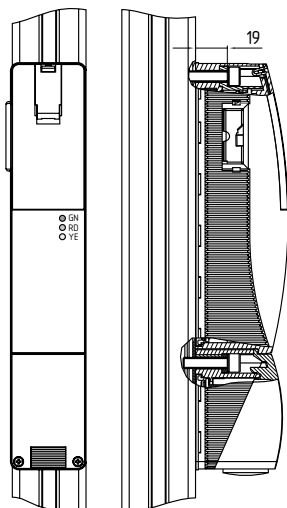

Mounting inside

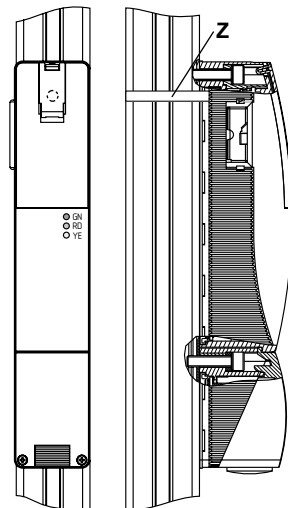

Step 3

- For **mounting outside**: Unscrew the cover of the actuator unit
- For **mounting inside**: Unscrew the cover of the emergency exit P1

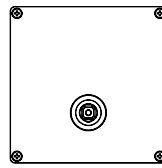

Step 4

Insert sliding blocks as shown (included in delivery)

To be observed:

- Observe the alignment (notch) of the sliding blocks

- E = Left hinged door
- D = Right hinged door

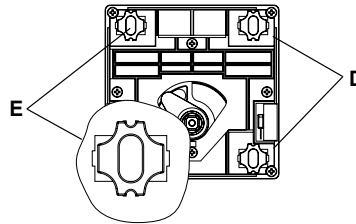

Step 5

- For **mounting outside**: Fit the actuator unit to the doorpost by means of the spacer **F**: (7,5 mm)
- For **mounting inside**: Fit the emergency exit P1 to the doorpost by means of the spacer **F**: (7,5 mm)

To be observed:

- Actuator unit or emergency exit completely retracted
- Distance between solenoid interlock and actuator unit or emergency exit = $7.5 + 0.5/-2.5$ mm
- Screws DIN 912-M6
- Torque MA = 8 Nm
- Wall thickness of the device 8 mm (see step 11)
- Washers DIN 125-6.4 (included in delivery)
- For applications with strong vibrations, please observe a proper securing of the screws

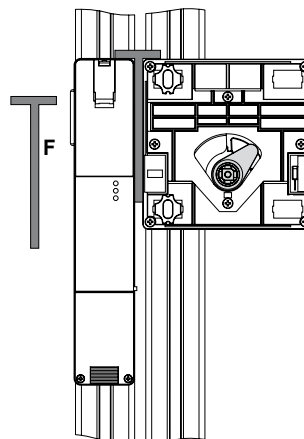

Step 6

- For **mounting outside**: Mount the cover on the actuator unit
 - For **mounting inside**: Mount the cover on the emergency exit P1
- To be observed:**
- Actuator unit or emergency exit completely retracted

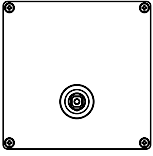

Step 7

- For **mounting outside**: Fit the door-handle
 - For **mounting inside**: Fit the emergency exit handle
- To be observed:**
- Mount the door handle or emergency release P1 horizontally
 - **D** = for left hinged doors
 - **E** = for right hinged door
 - **G** = Hexagonal screw A/F 3 with screw-lock (included in delivery)
 - For outdoor installation without emergency exit continue to paragraph 17



Sticker included in delivery of lockout tag.

Mounting outside

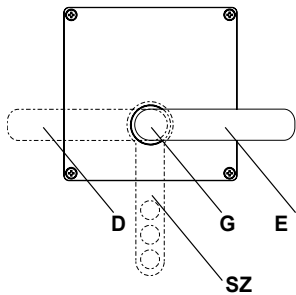

Mounting inside

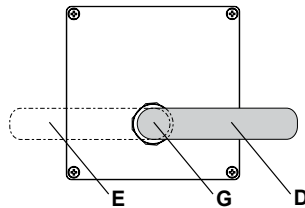

Step 8

If an emergency exit is available, cut square tube **H** at length. De-burr the cut sides.

To be observed:

- Max. door leaf thickness $S = 170$ mm
- Length of sawn off square rod **H**

Mounting outside

P1:	$L = S + 22 - 2$ mm
P20:	$L = S + 28$ mm
P25:	$L = S + 24$ mm
P30/P31:	$L = S + 50$ mm

Mounting inside

P1:	$L = S + 22 - 2$ mm
-----	---------------------

- Through-hole for square tube **H** $\varnothing 16$ mm

Mounting outside

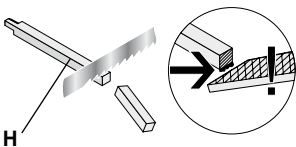

Mounting inside

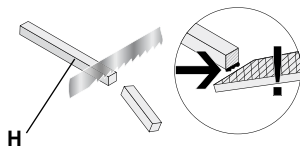

- For mounting outside and assembly with emergency exit P20 continue from paragraph 14
- emergency exit P25 continue from paragraph 15
- locking linkage P30 or P31 continue from paragraph 16

Step 9

- For **mounting outside**: Unscrew the cover of the emergency exit P1
- For **mounting inside**: Unscrew the cover of the actuator unit

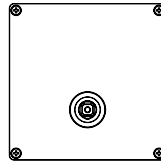

Step 10

Insert sliding blocks as shown (included in delivery)

To be observed:

- Observe the alignment (notch) of the sliding blocks
- **D** = for left hinged door
- **E** = for right hinged door

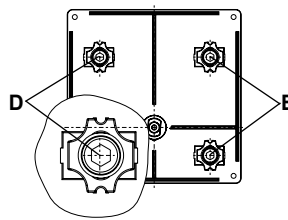

Step 11

- For **mounting outside**: Fit the bottom plate of the emergency exit **P1** to the door
- For **mounting inside**: Fit the bottom plate of the actuator unit to the door

To be observed:

- Actuator completely in **J** (actuator unit or emergency exit unit) retracted
- Arrange both the emergency exit and the actuator unit parallel
- Screws DIN 912-M6
- Torque $MA = 8$ Nm
- Wall thickness of the device 8 mm
- Washers $\varnothing 6.4$ DIN 125 (included in delivery)
- For applications with strong vibrations, please ensure the screws are correctly secured.

Mounting outside

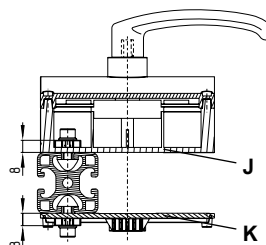

Mounting inside

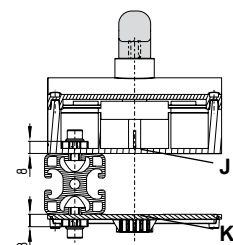

Step 12

- For **mounting outside**: Insert square rod **H** in the backside of the actuator unit
 - For **mounting inside**: Insert square rod **H** in the backside of the emergency exit P1
- To be observed:**
- For **mounting outside**: Insert chamfer of the square into the emergency exit either the cut side of the square into the actuator unit. Position of the chamfer as shown, when actuator unit is actuated.

Mounting outside

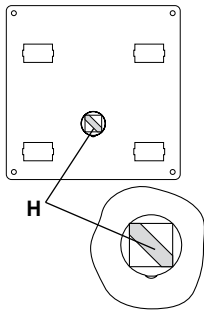

Mounting inside

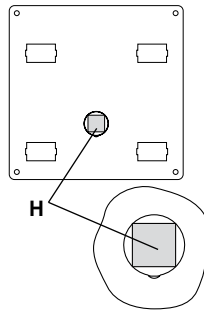

Step 13

- For **mounting outside**: Fit the cover and the handle onto the emergency exit
 - For **mounting inside**: Fit the cover and the handle onto the actuator unit
- To be observed:**
- Position of the driving shaft **I** as shown, when actuator unit is actuated
 - Functional test of the emergency exit handle: it should be possible to open the safety guard inside the hazardous area; it should not be possible to lock the safety guard from inside. The emergency exit handle must be in upright position when closed.
 - After successful assembly continue from paragraph 17

Mounting outside

Mounting inside

For left hinged door

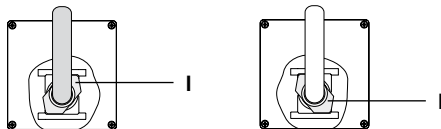

For right hinged door

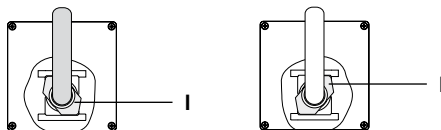

Step 14 - Mounting emergency exit P20

Only for mounting outside!

Fit emergency exit P20 to the door.

To be observed:

- Observe the position of the slotted hole
- Actuator completely inserted into the actuator unit **J**
- Emergency exit P20 parallel to actuator unit **J**
- Screws DIN 912-M6
- Torque MA = 8 Nm
- Wall thickness of the device 8 mm
- Washers Ø 6.4 DIN 125 (included in delivery)
- For applications with strong vibrations, please observe a proper securing of the screws
- After the assembly of the emergency exit P20, proceed with step 17

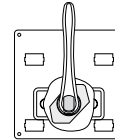

For left hinged door

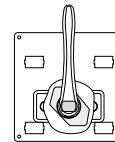

For right hinged door

Step 15 - Mounting emergency exit P25

Only for mounting outside!

Fit emergency exit P25 to the door.

To be observed:

- Observe the position of the slotted hole
- Actuator completely inserted into the actuator unit **J**
- Emergency exit P25 parallel to actuator unit **J**
- Screws DIN 912-M6
- Torque MA = 8 Nm
- Wall thickness of the device 8 mm
- For applications with strong vibrations, please observe a proper securing of the screws
- After the assembly of the emergency exit P25, proceed with step 17

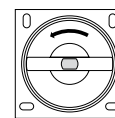

For left hinged door

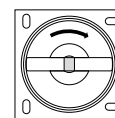

For right hinged door

Step 16 - Mounting of the P30 or P31 locking rod

Only for mounting outside!

Fit the locking rod without emergency exit P30 either with emergency exit P31.

To be observed:

- Refer to the operating instructions AZ/AZM 200-B30-P30/P31

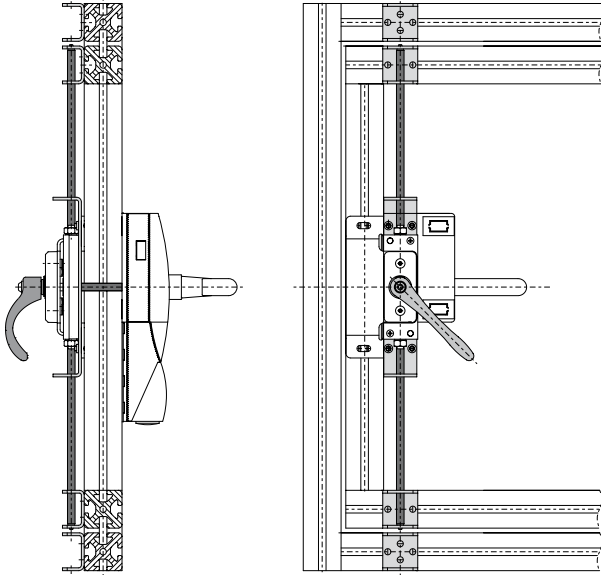

Step 17

Clip the dust-proof flap in the unused side.

To be observed:

- **D** = for left hinged door
- **E** = for right hinged door

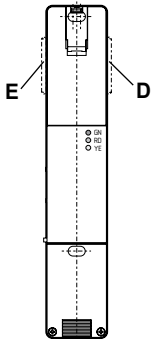

Step 18

After being put into operation, the manual release must be secured by installing the seal, which is included in delivery.

- For **mounting outside**: Seal the cover of the manual release **A**
- For **mounting inside**: Secure the access hole for the auxiliary release **A** with a seal

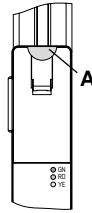

4.1 Set-up checklist



Checklist

Set-up and maintenance

Checking of the AZ/AZM 200 safety door-handle system
During the set-up and the regular maintenance of the machine, the following items of the safety door-handle system, consisting of the AZ or AZM 200, the corresponding actuator unit and the emergency exit, must be checked and inspected by a professional:

1. Fixation:
All fixing screws installed and tightened with the specified torque

2. Distance:
Distance 7.5 +0.5/-2.5 mm between AZ/AZM 200 and actuator unit observed.

3. Emergency exit handle:
After locking, the correct closing of the door must be checked.
It should be possible to open the safety guard inside the hazardous area;
it should not be possible to lock the safety guard from inside
It should be possible to open the safety guard inside the hazardous area;
it should not be possible to lock the safety guard from inside. The emergency exit handle must be in the upright position when closed.

4. Sticker emergency exit handle (included in delivery):
The sticker is visibly attached.

5. Dust shield cap:
Check tight fitting of the dust-proof flap

6. Functional testing:
The enabling signal is only transmitted to the safety circuit,
if the actuator is within range of the solenoid interlock and locked.

LED	STATUS
green	Operating voltage
yellow	Actuator inserted (and locked for AZM 200)
flashes yellow	Actuator inserted and not locked (only for AZM 200)
red	Error

7. Cover for manual release:
Access cover or access hole is sealed (only for AZM 200).

Date / Signature: _____

K. A. Schmersal GmbH & Co. KG
Möddinghofe 30, D - 42279 Wuppertal
Postfach 24 02 63, D - 42232 Wuppertal

Phone: +49 - (0)2 02 - 64 74 - 0
Telefax: +49 - (0)2 02 - 64 74 - 1 00
E-Mail: info@schmersal.com
Internet: <http://www.schmersal.com>