

Main

Accessory / separate part designation	5-wire connector adaptor
Accessory / separate part category	Cabling accessories
Accessory / separate part type	Connector adaptor
Cable composition	4 x 0.34 mm ² + 1 x 0.5 mm ²
Thread type	M20 x 1.5
[In] rated current	4 A

Complementary

Cable length	100 mm
Total number of wires	5
Electrical connection	1 male connector M12 5 straight
Cable connector fixing	Screw-on
Body material	Metal
Insulation resistance	> 1000000000 Ohm
Resistance across terminals	<= 5000 mOhm
[Ue] rated operational voltage	36 V DC 30 V AC
Product weight	0.025 kg

Environment

IP degree of protection	IP67
Ambient air temperature for operation	-25...80 °C

Offer Sustainability

Sustainable offer status	Not Green Premium product
RoHS (date code: YYWW)	Compliant - since 9830 - Schneider Electric declaration of conformity

Dimensions

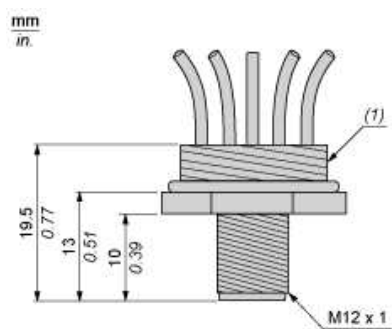

(1) Thread size M20 x 1.5

Connections and Schemes

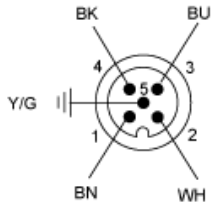

BN : Brown
BK : Black
BU : Blue
Y/G : Yellow / Green
WH : White