



Switching automation light grids PLG, PLG3

PLG3-270F431



Model Name > [PLG3-270F431](#)
Part No. > [1029130](#)



At a glance

- 360° visible job LED
- Range up to 2 m
- Flexible detection heights from 120 mm to 420 mm
- Immune to reflected and ambient light
- Switchable job LED: permanently lit or flashing
- Optically confirms the right bin was picked
- Bus connection possible

Your benefits

- The integrated job LED reduces the order picker's search time
- Low assembly costs thanks to the PLG's clever design
- High availability thanks to an integrated polarizing filter
- Tough aluminum housing ensures that sensor damage is kept to a minimum and helps reduce repair costs
- Reflective tape on the sensor avoids additional assembly and cabling costs



Features

Technology:	Retro-reflective light grid
Task:	Switching light grid
Minimum detectable object (MDO):	Parallel beam, 35 mm
Beam separation:	30 mm
Number of beams:	10
Detection height:	270 mm

Performance

Maximum range (PL150):	2 m
Minimum range:	≥100 mm
Working range (PL150):	1.3 m
Response time ¹⁾ :	Parallel beam: > 100 ms
Maximum range (reflective tape REF-PLG):	1.5 m
Working range (reflective tape REF-PLG):	1 m

¹⁾ With resistive load

Interfaces

Output type:	1 x PNP (Q)
Connection type:	Short cable (0.28 m) with connector M12, 4-pin
Input current:	12 mA
Job LED input:	PNP

Mechanics/electronics

Wave length:	650 nm
Supply voltage V_s ¹⁾ :	DC 15 V ... 30 V
Power consumption sender:	< 45 mA
Current consumption job LED ²⁾ :	10 mA
Ripple:	< 5 Vpp
Output current $I_{max.}$:	100 mA
Output load capacitive:	100 nF
Output load inductive:	1 H
Initialization time:	0.6 s
Dimensions (W x H x D):	35.6 mm x 349 mm x 19 mm
Housing material:	Aluminum
Indication:	LED
Enclosure rating:	IP 54
Circuit protection:	Output Q short-circuit protected Interference suppression VS connections reverse-polarity protected
Weight:	350 g
Front screen:	PMMA
Output mode ³⁾ :	Q dark switching

1) 2) Typical value 3) Q = active in case one beam is interrupted, /Q = active in case all beam are free

Ambient data

Protection class:	III
EMC:	EN 60947-5-2
Ambient temperature:	Operation: -10 ... +55 °C Storage: -40 ... +70 °C
Vibration resistance:	5 g, 10 Hz ... 55 Hz (IEC 68-2-6)
Shock load:	10 g/DIN EN 60068-2-29/16 ms

Dimensional drawing

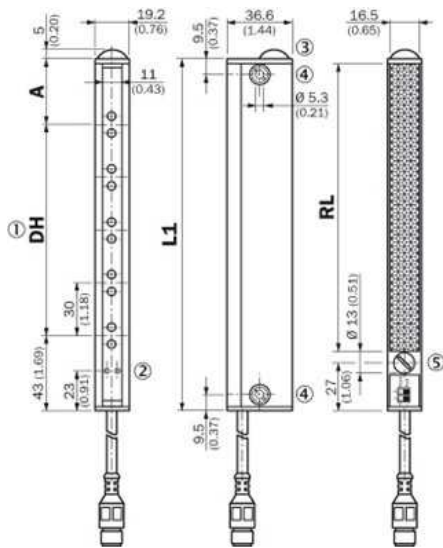

DH	A	L1	RL
120 (4.72)	36 (1.42)	199 (7.83)	162 (6.38)
210 (8.27)	26 (1.02)	279 (10.98)	242 (9.53)
270 (10.63)	36 (1.42)	349 (13.74)	312 (12.28)
360 (14.17)	26 (1.02)	429 (16.89)	392 (15.43)
420 (16.54)	36 (1.42)	499 (19.65)	462 (18.19)

- |1| Detection height (DH)
- |2| Indicator Power on: green; beam status: yellow
- |3| Job-LED, green
- |4| Mounting hole, \varnothing 5.3 mm
- |5| Configuration switches

Adjustments

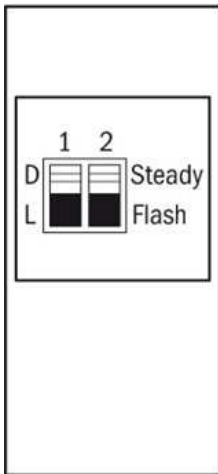

Configuration over switches

Switch 1	D	Output active, in case of blocked beams
	L	Output inactive, in case of blocked beams
Switch 2	Steady	Job-LED steady
	Flash	Job-LED flashes, 3 Hz

Connection type and diagram

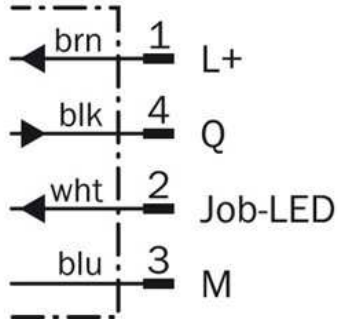

Characteristic curve: range

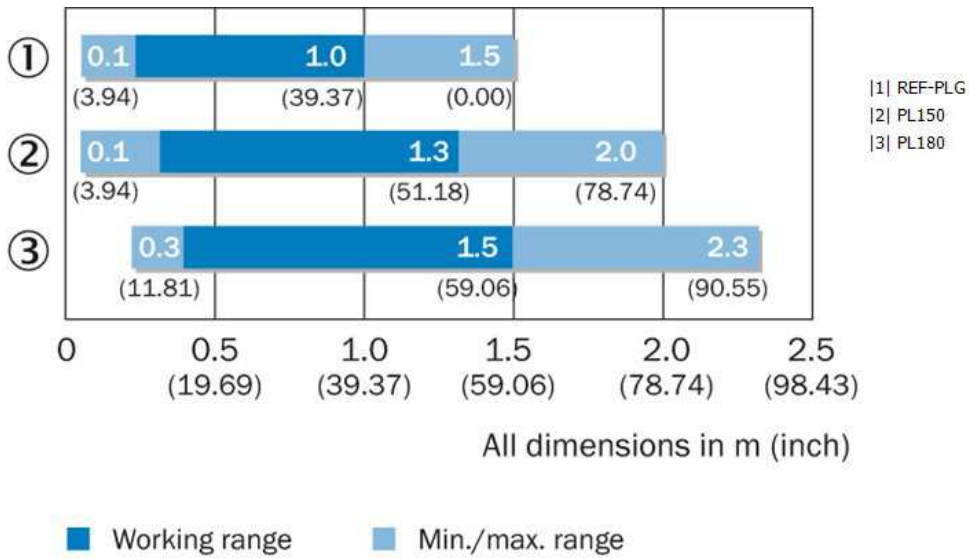

Australia

Phone +61 3 9457 0600
1800 33 48 02 – tollfree
E-Mail sales@sick.com.au

Belgium/Luxembourg

Phone +32 (0)2 466 55 66
E-Mail info@sick.be

Brasil

Phone +55 11 3215-4900
E-Mail marketing@sick.com.br

Canada

Phone +1 905 771 14 44
E-Mail information@sick.com

Česká republika

Phone +420 2 57 91 18 50
E-Mail sick@sick.cz

China

Phone +86 4000 121 000
E-Mail info.china@sick.net.cn
Phone +852-2153 6300
E-Mail ghk@sick.com.hk

Danmark

Phone +45 45 82 64 00
E-Mail sick@sick.dk

Deutschland

Phone +49 211 5301-301
E-Mail info@sick.de

España

Phone +34 93 480 31 00
E-Mail info@sick.es

France

Phone +33 1 64 62 35 00
E-Mail info@sick.fr

Great Britain

Phone +44 (0)1727 831121
E-Mail info@sick.co.uk

India

Phone +91-22-4033 8333
E-Mail info@sick-india.com

Israel

Phone +972-4-6881000
E-Mail info@sick-sensors.com

Italia

Phone +39 02 27 43 41
E-Mail info@sick.it

Japan

Phone +81 (0)3 5309 2112
E-Mail support@sick.jp

Magyarország

Phone +36 1 371 2680
E-Mail office@sick.hu

Nederland

Phone +31 (0)30 229 25 44
E-Mail info@sick.nl

Norge

Phone +47 67 81 50 00
E-Mail sick@sick.no

Österreich

Phone +43 (0)22 36 62 28 8-0
E-Mail office@sick.at

Polska

Phone +48 22 837 40 50
E-Mail info@sick.pl

România

Phone +40 356 171 120
E-Mail office@sick.ro

Russia

Phone +7-495-775-05-30
E-Mail info@sick.ru

Schweiz

Phone +41 41 619 29 39
E-Mail contact@sick.ch

Singapore

Phone +65 6744 3732
E-Mail sales.gsg@sick.com

Slovenija

Phone +386 (0)1-47 69 990
E-Mail office@sick.si

South Africa

Phone +27 11 472 3733
E-Mail info@sickautomation.co.za

South Korea

Phone +82 2 786 6321/4
E-Mail info@sickkorea.net

Suomi

Phone +358-9-25 15 800
E-Mail sick@sick.fi

Sverige

Phone +46 10 110 10 00
E-Mail info@sick.se

Taiwan

Phone +886 2 2375-6288
E-Mail sales@sick.com.tw

Türkiye

Phone +90 (216) 528 50 00
E-Mail info@sick.com.tr

United Arab Emirates

Phone +971 (0) 4 88 65 878
E-Mail info@sick.ae

USA/México

Phone +1(952) 941-6780
1 (800) 325-7425 – tollfree
E-Mail info@sickusa.com

More representatives and agencies
at www.sick.com