



3D vision
Gigabit Ethernet , Ruler, Ruler E1200, Ruler
E1200 S

Ruler-E1112



Model Name > [Ruler-E1112](#)
Part No. > [1029230](#)



At a glance

- Factory calibrated 3D in millimeters at full production speed
- High accuracy 3D for measurement widths from 100 mm up to 1.5 m
- Capture 3D, grayscale, and scatter at the same time
- Easy to integrate without need for external lights
- Rugged housing for tough environments and operation down to -30 °C
- Remote operation over long cable distances with Gigabit Ethernet

Your benefits

- High-speed measurement allows you to increase production throughput and still ensure product quality
- Accurate size and position measurement in 3D, regardless of an object's height or color, creating reliable solutions
- Simultaneously capturing 3D, scatter, and grayscale, allows for more reliable quality control and inspection
- Factory calibrated 3D with built-in lighting instantly provides results in millimeters, which makes integration easy
- Designed for tough industrial environments to ensure a long and problem-free life time

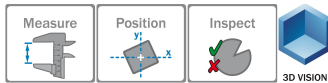

Features

Task:	Inspection, Measuring, Positioning
Description:	Ruler E1200 S - 2M Laser, Scatter measurements, up to 10 k profiles/second. Gigabit Ethernet interface, 1,024 px x 512 px.
Technology:	3D LineScan
Example field of view (H x W):	250 mm x 1,200 mm
Field of view width:	500 mm ... 1,550 mm
Sensing distance:	280 mm ... 1,280 mm
Maximum height range:	1,000 mm
Data synchronization:	Encoder triggered External trigger Free running
Grayscale measurements:	✓
Scatter measurement:	✓
Spectral range:	Ca. 630 nm ... 690 nm
Heating element:	-
Light source:	Visible red light (laser, 660 nm, ± 15 nm)

Laser class: 2M (IEC 60825-1 : 2008-01)
Factory calibrated: ✓

Performance

Image sensor: CMOS
Maximum performance: 10,000 3D profiles/s
Sensor resolution: 1,024 px x 512 px
3D profile resolution: 1,024 px
Typical height resolution: 0.4 mm
Gray line resolution: 1,024 px
Scatter resolution: 1,024 px

Interfaces

Configuration software: Ranger Studio
Communication interfaces: Gigabit Ethernet
Operating system: Windows 7, Windows XP Pro
Development environment: C, C++ (VS 2005/2008/2010)
Programming interface: iCon API
Digital inputs: 3 x HIGH = 10 V ... 28.8 V
Digital outputs: 2 x B-type, < 100 mA in total
Maximum encoder frequency: 2 MHz
Encoder interface: RS-422

Mechanics/electronics

Connectors: Harting Push Pull (Ethernet)
M12, 8-pin socket (encoder)
M12, 8-pin male connector (power I/O)
Connector material: Ethernet: thermoplast/anodized aluminum, M12: nickel-plated brass
Power consumption: 7 W
Power consumption: < 1 A
Ripple: < 5 Vpp
Enclosure rating: IP 65
Housing material: Aluminum
Housing color: Gray, varnished
Window material: Float glass, AR-coated
Weight: 7 kg
Dimensions (L x W x H): 420 mm x 107 mm x 163 mm

Ambient data

Shock load: 15 g, 3 x 6 directions
Vibration load: 5 g, 58 Hz ... 150 Hz
Ambient operating temperature: 0 °C ... +40 °C ¹⁾
Ambient storage temperature: -30 °C ... +70 °C ²⁾

1) 2) Non-condensing

Dimensional drawing

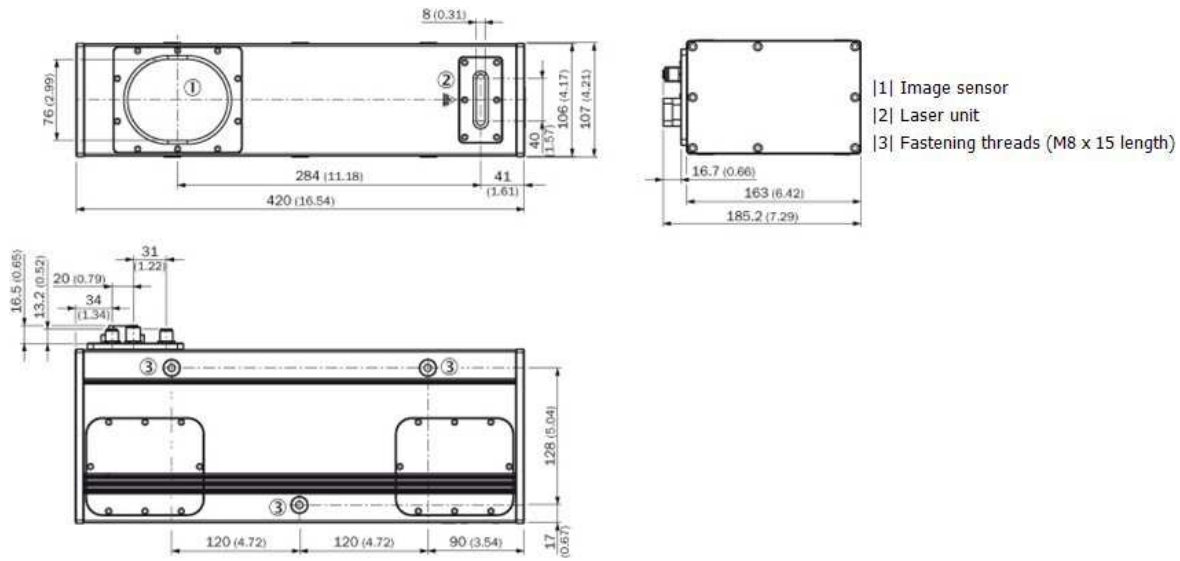

Measuring details

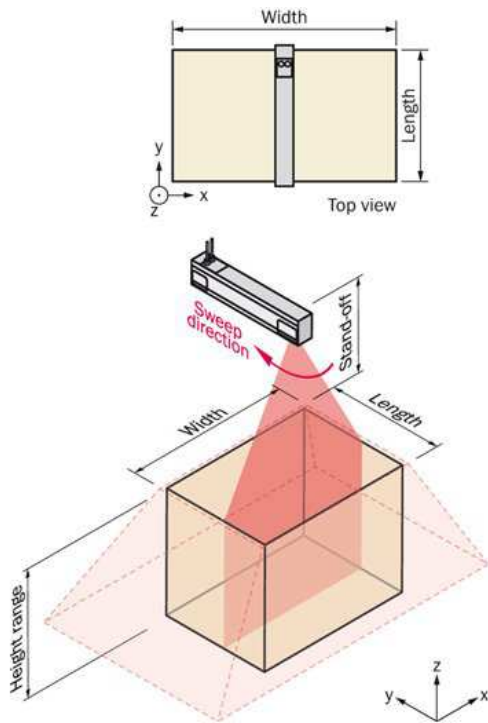

Connection type

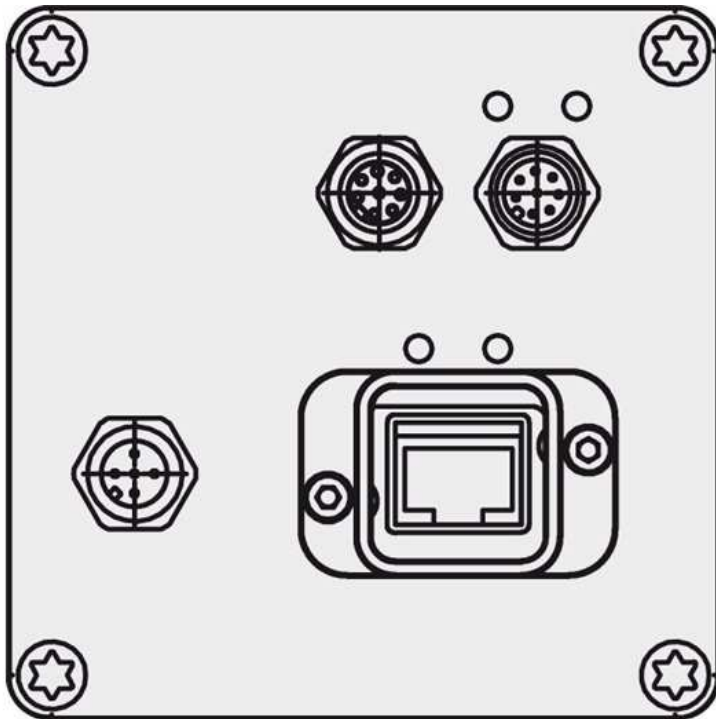

Connection diagram, Encoder connection

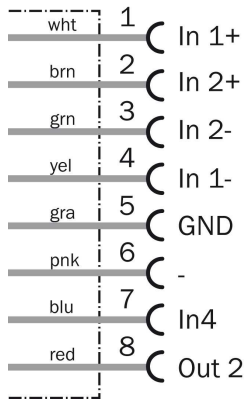

Connection diagram Power I/O

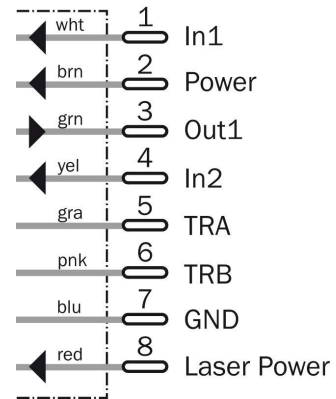

Australia

Phone +61 3 9457 0600
1800 33 48 02 – tollfree
E-Mail sales@sick.com.au

Belgium/Luxembourg

Phone +32 (0)2 466 55 66
E-Mail info@sick.be

Brasil

Phone +55 11 3215-4900
E-Mail marketing@sick.com.br

Canada

Phone +1 905 771 14 44
E-Mail information@sick.com

Česká republika

Phone +420 2 57 91 18 50
E-Mail sick@sick.cz

China

Phone +86 4000 121 000
E-Mail info.china@sick.net.cn
Phone +852-2153 6300
E-Mail ghk@sick.com.hk

Danmark

Phone +45 45 82 64 00
E-Mail sick@sick.dk

Deutschland

Phone +49 211 5301-301
E-Mail info@sick.de

España

Phone +34 93 480 31 00
E-Mail info@sick.es

France

Phone +33 1 64 62 35 00
E-Mail info@sick.fr

Great Britain

Phone +44 (0)1727 831121
E-Mail info@sick.co.uk

India

Phone +91-22-4033 8333
E-Mail info@sick-india.com

Israel

Phone +972-4-6881000
E-Mail info@sick-sensors.com

Italia

Phone +39 02 27 43 41
E-Mail info@sick.it

Japan

Phone +81 (0)3 5309 2112
E-Mail support@sick.jp

Magyarország

Phone +36 1 371 2680
E-Mail office@sick.hu

Nederland

Phone +31 (0)30 229 25 44
E-Mail info@sick.nl

Norge

Phone +47 67 81 50 00
E-Mail sick@sick.no

Österreich

Phone +43 (0)22 36 62 28 8-0
E-Mail office@sick.at

Polska

Phone +48 22 837 40 50
E-Mail info@sick.pl

România

Phone +40 356 171 120
E-Mail office@sick.ro

Russia

Phone +7-495-775-05-30
E-Mail info@sick.ru

Schweiz

Phone +41 41 619 29 39
E-Mail contact@sick.ch

Singapore

Phone +65 6744 3732
E-Mail sales.gsg@sick.com

Slovenija

Phone +386 (0)1-47 69 990
E-Mail office@sick.si

South Africa

Phone +27 11 472 3733
E-Mail info@sickautomation.co.za

South Korea

Phone +82 2 786 6321/4
E-Mail info@sickkorea.net

Suomi

Phone +358-9-25 15 800
E-Mail sick@sick.fi

Sverige

Phone +46 10 110 10 00
E-Mail info@sick.se

Taiwan

Phone +886 2 2375-6288
E-Mail sales@sick.com.tw

Türkiye

Phone +90 (216) 528 50 00
E-Mail info@sick.com.tr

United Arab Emirates

Phone +971 (0) 4 88 65 878
E-Mail info@sick.ae

USA/México

Phone +1(952) 941-6780
1 (800) 325-7425 – tollfree
E-Mail info@sickusa.com

More representatives and agencies
at www.sick.com