



## Absolute encoders ARS60 SSI/Parallel

ARS60-FDA00256



**Model Name** > [ARS60-FDA00256](#)  
**Part No.** > [1031554](#)



Illustration may differ

**At a glance**

- Absolute singleturn encoder
- Resolution: up to 15 bits (32,768 increments)
- Electrical interface: SSI with gray code type or gray capped
- Electrical interface: Parallel with gray, gray capped, binary, BCD code type
- Zero-set function
- Mechanical interfaces: face mount flange, servo flange, blind and through hollow shaft
- Enclosure rating: Up to IP66

**Your benefits**

- Optical and magnetic variants for the widest range of requirements
- Reduced maintenance costs thanks to magnetic, wearless scanning in single and multiturn design
- High level of productivity due to optical encoders with a high level of precision and fast calculation of positions
- Robust design for maximum system availability, even in extreme environmental conditions
- Absolutely compact - specially suited in cases where installation space is tight
- Flexible integration in all common networks



**Performance**

Max. number of steps per revolution:	256
Max. number of revolutions:	1
Resolution power:	256 x 1
Error limits:	0.035 ° (binary number of steps) 0.046 ° (non-binary number of steps)
Repeatability (Ta not constant):	0.005 °
Measuring step deviation:	0.005 °, 0.016 °
Measuring step:	360 ° /number of lines
Initialization time:	80 ms <sup>1)</sup>

<sup>1)</sup> Valid positional data can be read once this time has elapsed

**Mechanical data**

Mechanical interface: Through hollow shaft

Shaft diameter:	6 mm 8 mm 10 mm 12 mm 14 mm 15 mm 1/4 " 3/8 " <sup>1)</sup> 1/2 " <sup>1)</sup>
Mass:	0.3 kg
Start up torque:	2.2 Ncm
Operating torque:	1.6 Ncm
Maximum operating speed:	3,000 /min
Bearing lifetime:	3.6 x 10 <sup>9</sup> revolutions
Max. angular acceleration:	500,000 rad/s <sup>2</sup>
Permissible movement axial static/dynamic:	± 0.5 mm, ± 0.2 mm
Permissible movement radial static/dynamic:	± 0.3 mm, ± 0.1 mm
Operation of zero-set:	≥ 100 ms <sup>2)</sup>

<sup>1)</sup> Collets for 6, 8, 10, 12, 14 mm and 1/4 ", 3/8 " and 1/2 " as accessories, separate order item. For 15 mm shaft diameter collet is not needed. <sup>2)</sup> Only with shaft stationary (note initialisation time)

### Electrical data

---

Operating voltage range:	10 V DC ... 32 V DC
Operating power consumption (no load):	90 mA
MTTFd: mean time to dangerous failure:	300 a (EN ISO 13849-1) <sup>1)</sup>

<sup>1)</sup> This product is a standard product and does not constitute a safety component as defined in the Machinery Directive.

Calculation based on nominal load of components, average ambient

temperature 40°C, frequency of use 8760 h/a. All

electronic failures are considered hazardous. For more information, see document no. 8015532.

### Interfaces

---

Electrical interface:	Connector M23, 21-pin, radial
-----------------------	-------------------------------

### Ambient data

---

EMC:	(according to EN 61000-6-2 and EN 61000-6-3) <sup>1)</sup>
Enclosure rating:	IP 64 (according to IEC 60529), with mating connector fitted
Permissible relative humidity:	90 % (condensation of the optical scanning not permitted)
Working temperature range:	-20 °C ... 85 °C
Storage temperature range:	-40 °C ... 100 °C
Resistance to shocks:	50 g (according to EN 60068-2-27)
Resistance to vibration:	20 g, 10 Hz ... 2,000 Hz (according to EN 60068-2-6)

<sup>1)</sup>

## Dimensional drawing

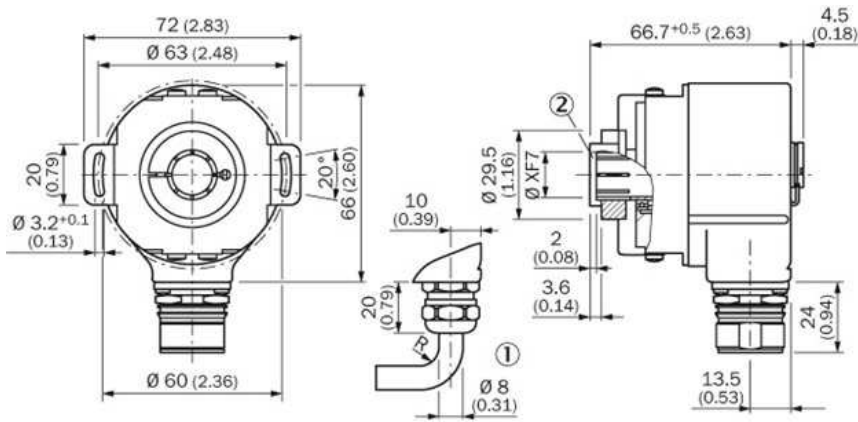

## PIN assignment

• Allocation for encoder with 21-pin connector Single, Parallel Interface

PIN	Wire color by cable outlet	Binary	Gray	BCD	Description
1	Lilac	2 <sup>11</sup>	G <sub>11</sub>	2 <sup>10</sup>	Data lines, outputs
2	White/brown	2 <sup>10</sup>	G <sub>10</sub>	2 <sup>9</sup>	
3	White/green	2 <sup>9</sup>	G <sub>9</sub>	2 <sup>8</sup>	
4	White/yellow	2 <sup>8</sup>	G <sub>8</sub>	2 <sup>7</sup>	
5	White/gray	2 <sup>7</sup>	G <sub>7</sub>	2 <sup>6</sup>	
6	White/pink	2 <sup>6</sup>	G <sub>6</sub>	2 <sup>5</sup>	
7	White/teal	2 <sup>5</sup>	G <sub>5</sub>	2 <sup>4</sup>	
8	White/red	2 <sup>4</sup>	G <sub>4</sub>	2 <sup>3</sup>	
9	White/black	2 <sup>3</sup>	G <sub>3</sub>	2 <sup>2</sup>	
10	Brown/green	2 <sup>2</sup>	G <sub>2</sub>	2 <sup>1</sup>	
11	Brown/yellow	2 <sup>1</sup>	G <sub>1</sub>	2 <sup>0</sup>	
12	Brown/gray	2 <sup>11</sup>	G <sub>11</sub>	2 <sup>10</sup>	
13	Brown/pink	2 <sup>10</sup>	G <sub>10</sub>	2 <sup>9</sup>	
14	Brown/blue	2 <sup>9</sup>	G <sub>9</sub>	2 <sup>8</sup>	
15	Brown/red	2 <sup>8</sup>	G <sub>8</sub>	2 <sup>7</sup>	
16	Green	Parity	Parity	Parity	
17	Pink	Strobe <sub>+</sub>	Strobe <sub>-</sub>	Strobe <sub>-</sub>	
18	Yellow	Enable <sub>+</sub>	Enable <sub>-</sub>	Enable <sub>-</sub>	
19	Brown	V/R <sub>+</sub>	V/R <sub>-</sub>	V/R <sub>-</sub>	
20	Gray	SET	SET	SET	
21	Blue	GND	GND	GND	
Housing	Red	V <sub>+</sub>	V <sub>+</sub>	V <sub>+</sub>	
		Screen	Screen	Screen	

<sup>1</sup> See see only possible with a cable outlet.

V<sub>+</sub> Supply voltage to the encoder. Before commissioning, note must be taken of the type label of the encoder.

GND Zero volt connection to the encoder, electrically isolated from the housing. The voltage referred to GND is V<sub>+</sub>.

V/R<sub>+</sub> Forward/reverse: This input programs the counting direction of the encoder. If not connected, this input is high. If the encoder starts, as viewed on the drive shaft, rotates in the clockwise direction, it counts in an increasing sequence. If it should count upwards when the shaft rotates in the anticlockwise direction, this connection must be connected permanently to low-level (zero volts).

Enable<sub>+</sub> This input activates the data output driver when a slow-level is applied. If not connected, this input is low. In the case of a high-level, the outputs are in the enable mode.

Strobe<sub>+</sub> This input stores the encoder data in Gray code when a slow-level is applied. This avoids a read error if the output data is requested in binary code. If this input is low, the data at the encoder output is stable, irrespective of whether the input shaft rotates. If not switched, this input is high.

Parity This output requires a high-level when the binary checksum of the data bits is even.

SET This input serves to set the zero electronically. If the SET line is connected to low for more than 100 ms, the mechanical position corresponds to the value 0.

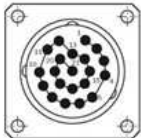

View of the connector M23 fitted to the encoder body Single, Parallel

Drehzahlbetrachtung

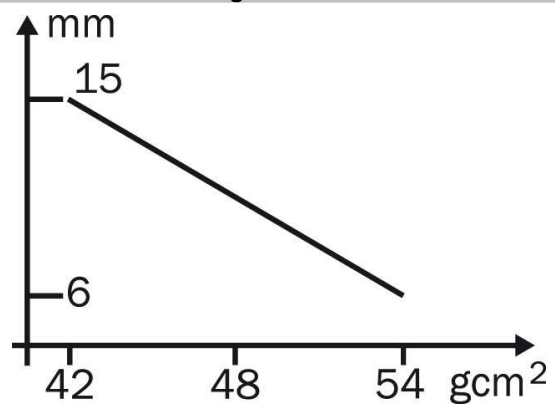

**Australia**

Phone +61 3 9457 0600  
1800 33 48 02 – tollfree  
E-Mail sales@sick.com.au

**Belgium/Luxembourg**

Phone +32 (0)2 466 55 66  
E-Mail info@sick.be

**Brasil**

Phone +55 11 3215-4900  
E-Mail marketing@sick.com.br

**Canada**

Phone +1 905 771 14 44  
E-Mail information@sick.com

**Česká republika**

Phone +420 2 57 91 18 50  
E-Mail sick@sick.cz

**China**

Phone +86 4000 121 000  
E-Mail info.china@sick.net.cn  
Phone +852-2153 6300  
E-Mail ghk@sick.com.hk

**Danmark**

Phone +45 45 82 64 00  
E-Mail sick@sick.dk

**Deutschland**

Phone +49 211 5301-301  
E-Mail info@sick.de

**España**

Phone +34 93 480 31 00  
E-Mail info@sick.es

**France**

Phone +33 1 64 62 35 00  
E-Mail info@sick.fr

**Great Britain**

Phone +44 (0)1727 831121  
E-Mail info@sick.co.uk

**India**

Phone +91-22-4033 8333  
E-Mail info@sick-india.com

**Israel**

Phone +972-4-6881000  
E-Mail info@sick-sensors.com

**Italia**

Phone +39 02 27 43 41  
E-Mail info@sick.it

**Japan**

Phone +81 (0)3 5309 2112  
E-Mail support@sick.jp

**Magyarország**

Phone +36 1 371 2680  
E-Mail office@sick.hu

**Nederland**

Phone +31 (0)30 229 25 44  
E-Mail info@sick.nl

**Norge**

Phone +47 67 81 50 00  
E-Mail sick@sick.no

**Österreich**

Phone +43 (0)22 36 62 28 8-0  
E-Mail office@sick.at

**Polska**

Phone +48 22 837 40 50  
E-Mail info@sick.pl

**România**

Phone +40 356 171 120  
E-Mail office@sick.ro

**Russia**

Phone +7-495-775-05-30  
E-Mail info@sick.ru

**Schweiz**

Phone +41 41 619 29 39  
E-Mail contact@sick.ch

**Singapore**

Phone +65 6744 3732  
E-Mail sales.gsg@sick.com

**Slovenija**

Phone +386 (0)1-47 69 990  
E-Mail office@sick.si

**South Africa**

Phone +27 11 472 3733  
E-Mail info@sickautomation.co.za

**South Korea**

Phone +82 2 786 6321/4  
E-Mail info@sickkorea.net

**Suomi**

Phone +358-9-25 15 800  
E-Mail sick@sick.fi

**Sverige**

Phone +46 10 110 10 00  
E-Mail info@sick.se

**Taiwan**

Phone +886 2 2375-6288  
E-Mail sales@sick.com.tw

**Türkiye**

Phone +90 (216) 528 50 00  
E-Mail info@sick.com.tr

**United Arab Emirates**

Phone +971 (0) 4 88 65 878  
E-Mail info@sick.ae

**USA/México**

Phone +1(952) 941-6780  
1 (800) 325-7425 – tollfree  
E-Mail info@sickusa.com

More representatives and agencies  
at [www.sick.com](http://www.sick.com)