



Wire draw encoders  
HighLine

PRF19-A1AM5010



**Model Name** > PRF19-A1AM5010  
**Part No.** > 1034328



*Illustration may differ*

**At a glance**

- Incremental wire draw encoders
- Modular measuring system with a wide selection of interfaces/measuring lengths
- Measuring lengths: 2 m ... 50 m
- Very rugged system (dirt wiper, integrated brushes), highly shock and vibration resistant
- High-quality winding mechanism and wire input
- Interfaces: - TTL/HTL
- High enclosure rating
- Highly resistant to shock and vibrations

**Your benefits**

- Reliable solution in harsh environments
- Long service life due to rugged industrial housing
- Quick and easy installation without the need for precise linear guidance
- Low integration and maintenance costs
- Customization option reduces inventory costs



**Performance**

Measurement range:	0 m ... 50 m
Repeatability:	≤ 5 mm <sup>1)</sup>
Linearity:	≤ ± 2 mm <sup>2)</sup>
Hysteresis:	≤ 10 mm <sup>3)</sup>
Resolution (wire draw + encoder)::	0.4 mm <sup>4) 5)</sup>

1) 3) Value refers to wire draw mechanism 2) 4) 5)

**Mechanical data**

Mass (including encoder):	16.8 kg
Measuring wire diameter:	1.35 mm
Measuring wire material:	Highly flexible stranded steel 1.4401 stainless steel V4A
Housing material, wire draw mechanism:	Aluminum (anodised), die-cast zinc
Spring return force:	18 N ... 37 N <sup>1)</sup>
Life of wire draw mechanism:	1 million cycles <sup>2)</sup>
Actual length of cable extension:	50.2 m
Wire acceleration:	18 m/s <sup>2</sup>
Operating speed:	4 m/s

Mounted encoder:	DFS60
Mounted mechanic:	MRA-F190-150D2
Part number mechanic:	6028630
Part number encoder:	-
Mass (measuring wire):	7.1 g/m
Length of wire pulled out per revolution:	491.5 mm <sup>3)</sup>
Pulses per revolution:	1,225 <sup>4)</sup>

1) These values were measured at an ambient temperature of 25 °C. There may be variations at other temperatures. <sup>2) 3) 4)</sup>

### Electrical data

---

Maximum output frequency:	600 kHz
Reference signal, position:	Electronically, gated with A and B
Reference signal, number:	1, electronically, gated with A and B
Maximum load current:	30 mA
Initialization time::	≤ 32 ms, with mechanical zero pulse width ≤ 30 ms <sup>1) 2)</sup>
Supply voltage:	4.5 V ... 32 V
Power consumption:	0.7 W
MTTFd: mean time to dangerous failure::	300 a <sup>3) 4)</sup>

1) 2) Valid positional data can be read once this time has elapsed. <sup>3)</sup> This product is a standard product and does not constitute a

safety component as defined in the Machinery Directive.

Calculation based on nominal load of components, average ambient

temperature 40°C, frequency of use 8760 h/a. All

electronic failures are considered hazardous. For more information, see document no. 8015532. <sup>4)</sup> The value applies to the mounted encoder

### Interfaces

---

Electrical interface:	4.5 V ... 5.5 V, TTL/RS422
Connection type:	Connector M23, 12-pin, radial
Encoder:	Incremental encoders

### Ambient data

---

EMC:	(according to EN 61000-6-2 and EN 61000-6-3)
Enclosure rating encoder:	IP 67
Enclosure rating mechanic:	IP 31
Resistance to shocks:	60 g, 6 ms (according to EN 60068-2-27)
Resistance to vibration:	20 g, 10 Hz ... 2,000 Hz (according to EN 60068-2-6)
Relative humidity/Condensation:	90 % (condensation of the optical scanning not permitted)
Working temperature range (encoder):	-30 °C ... +70 °C
Working temperature range (mechanics):	-30 °C ... +70 °C
Working temperature range (combination):	Wird definiert durch den höheren minimalen und niedrigeren maximalen Wert des Arbeitstemperaturbereichs von Encoder und Mechanik

# Dimensional drawing

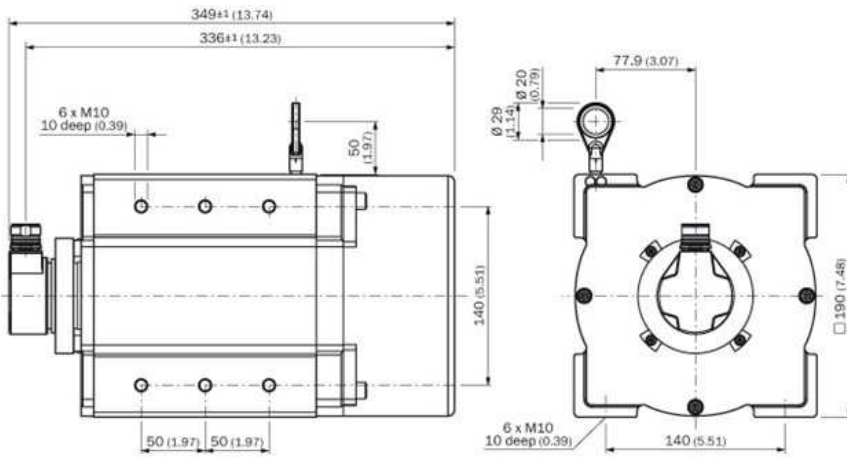

**Australia**

Phone +61 3 9457 0600  
1800 33 48 02 – tollfree  
E-Mail sales@sick.com.au

**Belgium/Luxembourg**

Phone +32 (0)2 466 55 66  
E-Mail info@sick.be

**Brasil**

Phone +55 11 3215-4900  
E-Mail marketing@sick.com.br

**Canada**

Phone +1 905 771 14 44  
E-Mail information@sick.com

**Česká republika**

Phone +420 2 57 91 18 50  
E-Mail sick@sick.cz

**China**

Phone +86 4000 121 000  
E-Mail info.china@sick.net.cn  
Phone +852-2153 6300  
E-Mail ghk@sick.com.hk

**Danmark**

Phone +45 45 82 64 00  
E-Mail sick@sick.dk

**Deutschland**

Phone +49 211 5301-301  
E-Mail info@sick.de

**España**

Phone +34 93 480 31 00  
E-Mail info@sick.es

**France**

Phone +33 1 64 62 35 00  
E-Mail info@sick.fr

**Great Britain**

Phone +44 (0)1727 831121  
E-Mail info@sick.co.uk

**India**

Phone +91-22-4033 8333  
E-Mail info@sick-india.com

**Israel**

Phone +972-4-6881000  
E-Mail info@sick-sensors.com

**Italia**

Phone +39 02 27 43 41  
E-Mail info@sick.it

**Japan**

Phone +81 (0)3 5309 2112  
E-Mail support@sick.jp

**Magyarország**

Phone +36 1 371 2680  
E-Mail office@sick.hu

**Nederland**

Phone +31 (0)30 229 25 44  
E-Mail info@sick.nl

**Norge**

Phone +47 67 81 50 00  
E-Mail sick@sick.no

**Österreich**

Phone +43 (0)22 36 62 28 8-0  
E-Mail office@sick.at

**Polska**

Phone +48 22 837 40 50  
E-Mail info@sick.pl

**România**

Phone +40 356 171 120  
E-Mail office@sick.ro

**Russia**

Phone +7-495-775-05-30  
E-Mail info@sick.ru

**Schweiz**

Phone +41 41 619 29 39  
E-Mail contact@sick.ch

**Singapore**

Phone +65 6744 3732  
E-Mail sales.gsg@sick.com

**Slovenija**

Phone +386 (0)1-47 69 990  
E-Mail office@sick.si

**South Africa**

Phone +27 11 472 3733  
E-Mail info@sickautomation.co.za

**South Korea**

Phone +82 2 786 6321/4  
E-Mail info@sickkorea.net

**Suomi**

Phone +358-9-25 15 800  
E-Mail sick@sick.fi

**Sverige**

Phone +46 10 110 10 00  
E-Mail info@sick.se

**Taiwan**

Phone +886 2 2375-6288  
E-Mail sales@sick.com.tw

**Türkiye**

Phone +90 (216) 528 50 00  
E-Mail info@sick.com.tr

**United Arab Emirates**

Phone +971 (0) 4 88 65 878  
E-Mail info@sick.ae

**USA/México**

Phone +1(952) 941-6780  
1 (800) 325-7425 – tollfree  
E-Mail info@sickusa.com

More representatives and agencies  
at [www.sick.com](http://www.sick.com)