



Motor feedback systems rotary HIPERFACE® SRS/SRM50

SRM50-HAA0-K21



Model Name > SRM50-HAA0-K21
Part No. > 1037063



Illustration may differ

At a glance

- Motor feedback systems for the top performance range
- 1,024 sine/ cosine periods per revolution
- Absolute position with a resolution of 32,768 increments per revolution and 4,096 revolutions with the multiturn system
- HIPERFACE® interface: Programming of the position value and electronic type label
- Insert shaft or tapered shaft with various torque supports
- Integrated version, mounted version or stand-alone design
- Certified according to SIL2/PL d (only valid for SRS50S/SRM50S...)
- Conforms to RoHs

Your benefits

- Motor feedback system with HIPERFACE® interface
- High shock/vibration resistance thanks to built-in metal code disk
- Consistent motor design due to identical size of single and multiturn design
- To use of a motor feedback system certified to SIL2/PL d makes it easier to have your system certified.
- Very smooth running thanks to maximum ball bearing distance



Performance

Number of sine/cosine periods per revolution:	1,024
Number of the absolute ascertainable revolutions:	4,096 (Multiturn)
Total number of steps:	134,217,728
Measuring step:	0.3 angular seconds at interpolation of the sine/cosine signals with e.g. 12 Bit
Differential non-linearity:	± 7 angular seconds (Non-linearity within a sine/cosine period)
Operating speed:	6,000 /min, up to which the absolute position can be reliably produced
Available memory area:	128 Byte, 128 Byte (E2PROM 512)
Integral non-linearity typ.:	± 45 angular seconds (Error limits for evaluating sine/cosine period) without mechanical tension of the stator coupling

Mechanical data

Shaft diameter:	7 mm
Flange type/stator coupling:	Rubber support
Dimensions:	See dimensional drawing
Moment of inertia of the rotor:	10 gcm ²
Maximum operating speed:	12,000 /min

Maximum angular acceleration:	200,000 rad/s ²
Operating torque:	0.2 Ncm
Start up torque:	0.4 Ncm
Permissible shaft movement, radial, static:	± 0.5 mm
Permissible shaft movement, radial, dynamic:	± 0.1 mm
Permissible shaft movement, axial, static:	± 0.75 mm
Permissible shaft movement, axial, dynamic:	± 0.2 mm
Life of ball bearings:	3.6 x 10 ⁹ revolutions
Connection type:	Connector, 8-pin
Shaft version:	Plug-in shaft
Angular motion perpendicular to the rotational axis, static:	± 0.005 mm/mm
Angular motion perpendicular to the rotational axis, dynamic:	± 0.002 mm/mm
GEWICHT01:	0.2 kg

Electrical data

Electrical interface:	HIPERFACE
Operating voltage range/supply Voltage:	7 V DC ... 12 V DC
Recommended supply voltage:	8 V DC
Output frequency for sine/cosine signals:	0 kHz ... 200 kHz
Operating power consumption (no load):	80 mA ¹⁾

¹⁾ Without load

Interfaces

Type of code for the absolute value:	Binary
Code sequence:	Increasing, for clockwise shaft rotation, looking in direction "A" (see dimensional drawing)
Interface signals:	Parameter channel RS 485: digital, Process data channel SIN, REFSIN, COS, REFCOS: analog, differential

Ambient data

Working temperature range:	-30 °C ... +115 °C
Storage temperature range:	-40 °C ... +125 °C, without package
Relative humidity/Condensation:	90 %, Condensation not permitted
Resistance to shocks:	100 g/10 ms/according to EN 60068-2-27
Resistance to vibration:	20 g/10 Hz/2,000 Hz/according to EN 60068-2-6
EMC:	(according to EN 61000-6-2 and EN 61000-6-3) ¹⁾
Enclosure rating:	IP 40 (according to IEC 60529), with mating connector inserted

¹⁾ The EMC according to the standards quoted is achieved when the motor feedback system is mounted in an electrically conductive housing, which is connected to the central earthing point of the motor controller via a cable screen. This is also where the GND (0 V) connection of the power supply voltage is linked to earth. Users must perform their own tests when other screen designs are used.

Dimensional drawing

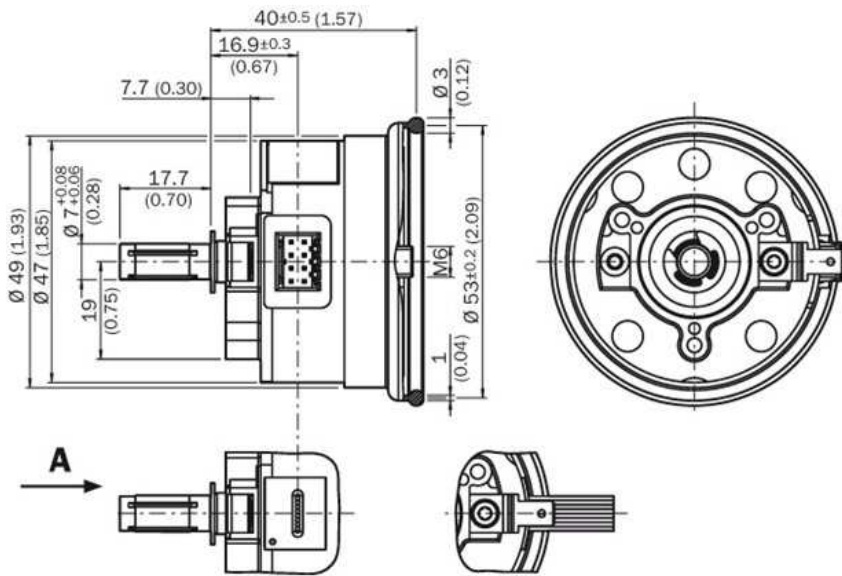

Australia

Phone +61 3 9457 0600
1800 33 48 02 – tollfree
E-Mail sales@sick.com.au

Belgium/Luxembourg

Phone +32 (0)2 466 55 66
E-Mail info@sick.be

Brasil

Phone +55 11 3215-4900
E-Mail marketing@sick.com.br

Canada

Phone +1 905 771 14 44
E-Mail information@sick.com

Česká republika

Phone +420 2 57 91 18 50
E-Mail sick@sick.cz

China

Phone +86 4000 121 000
E-Mail info.china@sick.net.cn
Phone +852-2153 6300
E-Mail ghk@sick.com.hk

Danmark

Phone +45 45 82 64 00
E-Mail sick@sick.dk

Deutschland

Phone +49 211 5301-301
E-Mail info@sick.de

España

Phone +34 93 480 31 00
E-Mail info@sick.es

France

Phone +33 1 64 62 35 00
E-Mail info@sick.fr

Great Britain

Phone +44 (0)1727 831121
E-Mail info@sick.co.uk

India

Phone +91-22-4033 8333
E-Mail info@sick-india.com

Israel

Phone +972-4-6881000
E-Mail info@sick-sensors.com

Italia

Phone +39 02 27 43 41
E-Mail info@sick.it

Japan

Phone +81 (0)3 5309 2112
E-Mail support@sick.jp

Magyarország

Phone +36 1 371 2680
E-Mail office@sick.hu

Nederland

Phone +31 (0)30 229 25 44
E-Mail info@sick.nl

Norge

Phone +47 67 81 50 00
E-Mail sick@sick.no

Österreich

Phone +43 (0)22 36 62 28 8-0
E-Mail office@sick.at

Polska

Phone +48 22 837 40 50
E-Mail info@sick.pl

România

Phone +40 356 171 120
E-Mail office@sick.ro

Russia

Phone +7-495-775-05-30
E-Mail info@sick.ru

Schweiz

Phone +41 41 619 29 39
E-Mail contact@sick.ch

Singapore

Phone +65 6744 3732
E-Mail sales.gsg@sick.com

Slovenija

Phone +386 (0)1-47 69 990
E-Mail office@sick.si

South Africa

Phone +27 11 472 3733
E-Mail info@sickautomation.co.za

South Korea

Phone +82 2 786 6321/4
E-Mail info@sickkorea.net

Suomi

Phone +358-9-25 15 800
E-Mail sick@sick.fi

Sverige

Phone +46 10 110 10 00
E-Mail info@sick.se

Taiwan

Phone +886 2 2375-6288
E-Mail sales@sick.com.tw

Türkiye

Phone +90 (216) 528 50 00
E-Mail info@sick.com.tr

United Arab Emirates

Phone +971 (0) 4 88 65 878
E-Mail info@sick.ae

USA/México

Phone +1(952) 941-6780
1 (800) 325-7425 – tollfree
E-Mail info@sickusa.com

More representatives and agencies
at www.sick.com