



## Motor feedback systems rotary HIPERFACE® SRS/SRM50

SRM50-HGV0-K21



**Model Name** > SRM50-HGV0-K21  
**Part No.** > 1037081



*Illustration may differ*

**At a glance**

- Motor feedback systems for the top performance range
- 1,024 sine/ cosine periods per revolution
- Absolute position with a resolution of 32,768 increments per revolution and 4,096 revolutions with the multiturn system
- HIPERFACE® interface: Programming of the position value and electronic type label
- Insert shaft or tapered shaft with various torque supports
- Integrated version, mounted version or stand-alone design
- Certified according to SIL2/PL d (only valid for SRS50S/SRM50S...)
- Conforms to RoHs

**Your benefits**

- Motor feedback system with HIPERFACE® interface
- High shock/vibration resistance thanks to built-in metal code disk
- Consistent motor design due to identical size of single and multiturn design
- To use of a motor feedback system certified to SIL2/PL d makes it easier to have your system certified.
- Very smooth running thanks to maximum ball bearing distance



**Performance**

Number of sine/cosine periods per revolution:	1,024
Number of the absolute ascertainable revolutions:	4,096 (Multiturn)
Total number of steps:	134,217,728
Measuring step:	0.3 angular seconds at interpolation of the sine/cosine signals with e.g. 12 Bit
Differential non-linearity:	± 7 angular seconds (Non-linearity within a sine/cosine period)
Operating speed:	6,000 /min, up to which the absolute position can be reliably produced
Available memory area:	128 Byte, 128 Byte (E2PROM 512)
Integral non-linearity typ.:	± 45 angular seconds (Error limits for evaluating sine/cosine period) without mechanical tension of the stator coupling

**Mechanical data**

Flange type/stator coupling:	Resolver support
Dimensions:	See dimensional drawing
Moment of inertia of the rotor:	10 gcm <sup>2</sup>
Maximum operating speed:	12,000 /min
Maximum angular acceleration:	200,000 rad/s <sup>2</sup>

Operating torque:	0.2 Ncm
Start up torque:	0.4 Ncm
Permissible shaft movement, radial, static:	± 0.25 mm
Permissible shaft movement, radial, dynamic:	± 0.1 mm
Permissible shaft movement, axial, static:	± 0.75 mm
Permissible shaft movement, axial, dynamic:	± 0.2 mm
Life of ball bearings:	3.6 x 10 <sup>9</sup> revolutions
Connection type:	Cable, 8-pin, radial, 200 mm
Shaft version:	Tapered shaft
Angular motion perpendicular to the rotational axis, static:	± 0.005 mm/mm
Angular motion perpendicular to the rotational axis, dynamic:	± 0.002 mm/mm
GEWICHT01:	0.2 kg

### Electrical data

---

Electrical interface:	HIPERFACE
Operating voltage range/supply Voltage:	7 V DC ... 12 V DC
Recommended supply voltage:	8 V DC
Output frequency for sine/cosine signals:	0 kHz ... 200 kHz
Operating power consumption (no load):	80 mA <sup>1)</sup>

<sup>1)</sup> Without load

### Interfaces

---

Type of code for the absolute value:	Binary
Code sequence:	Increasing, for clockwise shaft rotation, looking in direction "A" (see dimensional drawing)
Interface signals:	Parameter channel RS 485: digital, Process data channel SIN, REFSIN, COS, REFCOS: analog, differential

### Ambient data

---

Working temperature range:	-30 °C ... +115 °C
Storage temperature range:	-40 °C ... +125 °C, without package
Relative humidity/Condensation:	90 %, Condensation not permitted
Resistance to shocks:	100 g/10 ms/according to EN 60068-2-27
Resistance to vibration:	20 g/10 Hz/2,000 Hz/according to EN 60068-2-6
EMC:	(according to EN 61000-6-2 and EN 61000-6-3) <sup>1)</sup>
Enclosure rating:	IP 40 (according to IEC 60529), with mating connector inserted

<sup>1)</sup> The EMC according to the standards quoted is achieved when the motor feedback system is mounted in an electrically conductive housing, which is connected to the central earthing point of the motor controller via a cable screen. This is also where the GND (0 V) connection of the power supply voltage is linked to earth. Users must perform their own tests when other screen designs are used.

Dimensional drawing

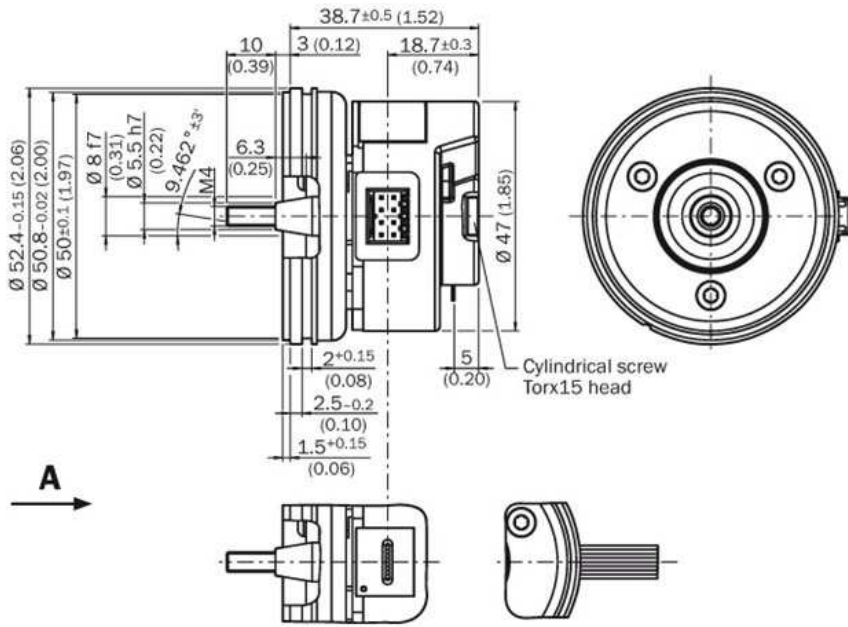

**Australia**

Phone +61 3 9457 0600  
1800 33 48 02 – tollfree  
E-Mail sales@sick.com.au

**Belgium/Luxembourg**

Phone +32 (0)2 466 55 66  
E-Mail info@sick.be

**Brasil**

Phone +55 11 3215-4900  
E-Mail marketing@sick.com.br

**Canada**

Phone +1 905 771 14 44  
E-Mail information@sick.com

**Česká republika**

Phone +420 2 57 91 18 50  
E-Mail sick@sick.cz

**China**

Phone +86 4000 121 000  
E-Mail info.china@sick.net.cn  
Phone +852-2153 6300  
E-Mail ghk@sick.com.hk

**Danmark**

Phone +45 45 82 64 00  
E-Mail sick@sick.dk

**Deutschland**

Phone +49 211 5301-301  
E-Mail info@sick.de

**España**

Phone +34 93 480 31 00  
E-Mail info@sick.es

**France**

Phone +33 1 64 62 35 00  
E-Mail info@sick.fr

**Great Britain**

Phone +44 (0)1727 831121  
E-Mail info@sick.co.uk

**India**

Phone +91-22-4033 8333  
E-Mail info@sick-india.com

**Israel**

Phone +972-4-6881000  
E-Mail info@sick-sensors.com

**Italia**

Phone +39 02 27 43 41  
E-Mail info@sick.it

**Japan**

Phone +81 (0)3 5309 2112  
E-Mail support@sick.jp

**Magyarország**

Phone +36 1 371 2680  
E-Mail office@sick.hu

**Nederland**

Phone +31 (0)30 229 25 44  
E-Mail info@sick.nl

**Norge**

Phone +47 67 81 50 00  
E-Mail sick@sick.no

**Österreich**

Phone +43 (0)22 36 62 28 8-0  
E-Mail office@sick.at

**Polska**

Phone +48 22 837 40 50  
E-Mail info@sick.pl

**România**

Phone +40 356 171 120  
E-Mail office@sick.ro

**Russia**

Phone +7-495-775-05-30  
E-Mail info@sick.ru

**Schweiz**

Phone +41 41 619 29 39  
E-Mail contact@sick.ch

**Singapore**

Phone +65 6744 3732  
E-Mail sales.gsg@sick.com

**Slovenija**

Phone +386 (0)1-47 69 990  
E-Mail office@sick.si

**South Africa**

Phone +27 11 472 3733  
E-Mail info@sickautomation.co.za

**South Korea**

Phone +82 2 786 6321/4  
E-Mail info@sickkorea.net

**Suomi**

Phone +358-9-25 15 800  
E-Mail sick@sick.fi

**Sverige**

Phone +46 10 110 10 00  
E-Mail info@sick.se

**Taiwan**

Phone +886 2 2375-6288  
E-Mail sales@sick.com.tw

**Türkiye**

Phone +90 (216) 528 50 00  
E-Mail info@sick.com.tr

**United Arab Emirates**

Phone +971 (0) 4 88 65 878  
E-Mail info@sick.ae

**USA/México**

Phone +1(952) 941-6780  
1 (800) 325-7425 – tollfree  
E-Mail info@sickusa.com

More representatives and agencies  
at [www.sick.com](http://www.sick.com)