



Photoelectric sensors  
W4S-3 Inox Hygiene, Photoelectric retro-reflective sensor, autocollimation

WL4S-3N1132H



**Model Name** > **WL4S-3N1132H**  
**Part No.** > **1048119**



*Illustration may differ*

**At a glance**

- Hygienic designed stainless steel housing and accessories (316L/1.4404)
- Hygienic mounting using M12-adapter thread or D12-adapter shaft
- IP 66, IP 67, IP 68 and IP 69K enclosure rating and Ecolab certified
- Resistant to a variety of common cleaning and disinfection agents
- Stainless steel teach-in pushbutton with a metal membrane
- PinPoint LED technology provides a highly visible laser-like light spot
- Hygienical designed and chemically resistant reflectors available as accessories

**Your benefits**

- Smooth hygienic housing and accessories with no grooves or crevices eliminates the potential for bacteria to grow, providing a more hygienic solution.
- Long service life in harsh conditions ensures less downtime and fewer replacement costs
- Quick and easy adjustment via a stainless steel metal membrane teach-in pushbutton
- Quick and easy alignment due to highly visible PinPoint emitter LED



**Features**

Sensor/detection principle:	Photoelectric retro-reflective sensor, autocollimation
Dimensions (W x H x D):	15.25 mm x 49.2 mm x 22.15 mm
Housing design:	Hygiene
Housing design (light emission):	Rectangular
Sensing range max.:	0 m ... 5 m <sup>1)</sup>
Sensing range:	0 m ... 3 m <sup>2)</sup>
Type of light:	Visible red light
Light source:	PinPoint LED <sup>3)</sup>
Wave length:	650 nm
Teach-in:	Single teach-in button
Adjustment:	Teach-in
Light spot size (distance):	Ø 45 mm (1.5 m)

1) 2) PL80A 3) Average service life of 100,000 h at T<sub>A</sub> = +25 °C

**Mechanics/electronics**

Supply voltage:	10 V DC ... 30 V DC <sup>1)</sup>
Power consumption:	≤ 30 mA <sup>2)</sup>
Output type:	NPN
Switching mode:	Light/dark switching
Output current I <sub>max</sub> :	≤ 100 mA
Response time:	< 0.5 ms <sup>3)</sup>
Switching frequency:	1,000 Hz <sup>4)</sup>
Connection type:	Cable, 4-wire, 2 m <sup>5)</sup>
Cable material:	PVC
Conductor cross-section:	0.14 mm <sup>2</sup>
Circuit protection:::	A B C <sup>6) 7) 8)</sup>
Protection class:	III
Weight:	80 g
Polarisation filter:	✓
Housing material:	Stainless steel, Stainless steel 316L
Enclosure rating:	IP 66 IP 67 IP 68 IP 69K
Ambient operating temperature:	-30 °C ... 60 °C, -30 °C ... 70 °C <sup>9)</sup>
Ambient storage temperature:	-30 °C ... 75 °C
UL File No.:	FDA, UL No. NRKH.E181493 & cUL No. NRKH7.E181493

<sup>1)</sup> Limit values, reverse-polarity protected, operation in short-circuit protected network: max. 8 A <sup>2)</sup> Without load <sup>3)</sup> Signal transit time with resistive load <sup>4)</sup> With light/dark ratio 1:1 <sup>5)</sup> Do not bend below 0 °C <sup>6)</sup> A = V<sub>S</sub> connections reverse-polarity protected <sup>7)</sup> B = inputs and output reverse-polarity protected <sup>8)</sup> C = interference suppression <sup>9)</sup> At UV ≤ 24 V and IA < 30 mA

**Dimensional drawing**

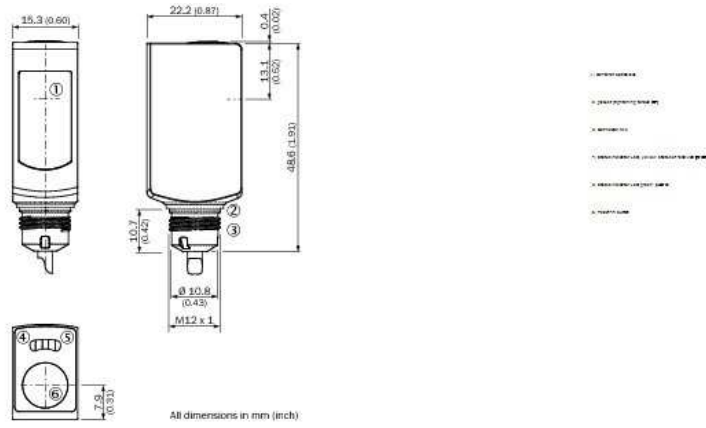

**Connection diagram**

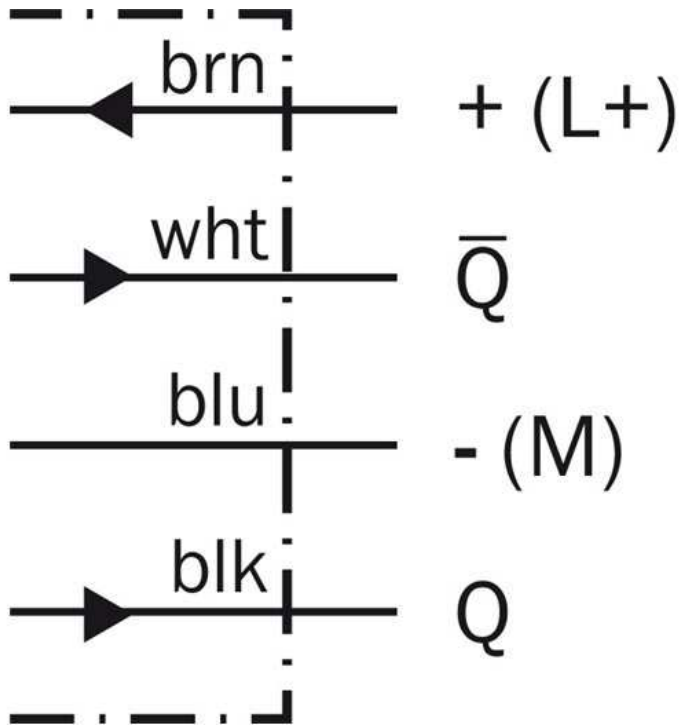

## Characteristic curve

Operating reserve

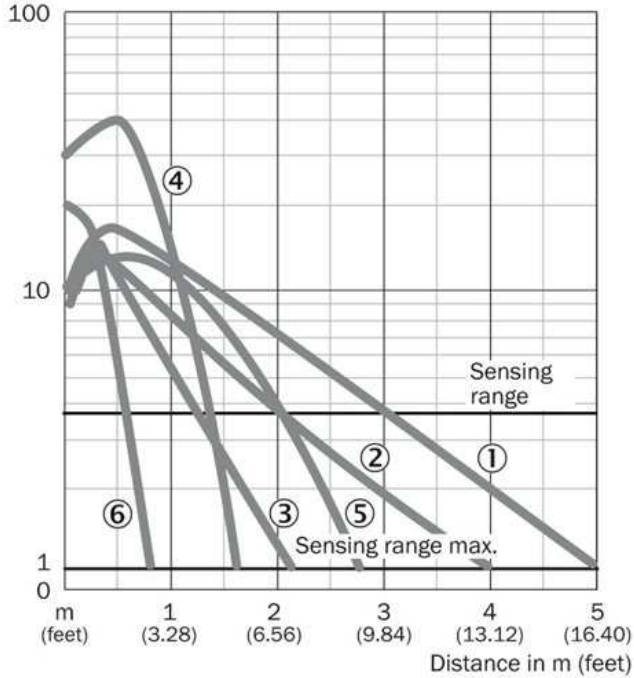

- |1| PL80A
- |2| PL40A
- |3| PL20A
- |4| PL10F
- |5| P250 CHEM
- |6| REF-IRF-56

## Sensing range diagram

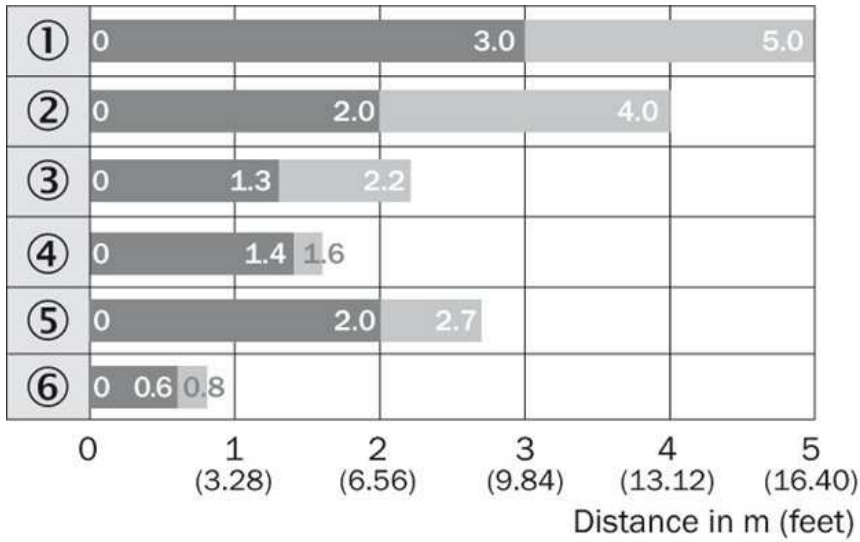

- |1| PL80A
- |2| PL40A
- |3| PL20A
- |4| PL10F
- |5| P250 CHEM
- |6| REF-IRF-56

■ Sensing range      ■ Sensing range max.

Connection type

---

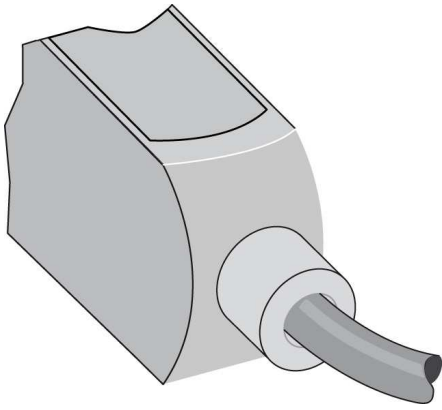

**Australia**

Phone +61 3 9457 0600  
1800 33 48 02 – tollfree  
E-Mail sales@sick.com.au

**Belgium/Luxembourg**

Phone +32 (0)2 466 55 66  
E-Mail info@sick.be

**Brasil**

Phone +55 11 3215-4900  
E-Mail marketing@sick.com.br

**Canada**

Phone +1 905 771 14 44  
E-Mail information@sick.com

**Česká republika**

Phone +420 2 57 91 18 50  
E-Mail sick@sick.cz

**China**

Phone +86 4000 121 000  
E-Mail info.china@sick.net.cn  
Phone +852-2153 6300  
E-Mail ghk@sick.com.hk

**Danmark**

Phone +45 45 82 64 00  
E-Mail sick@sick.dk

**Deutschland**

Phone +49 211 5301-301  
E-Mail info@sick.de

**España**

Phone +34 93 480 31 00  
E-Mail info@sick.es

**France**

Phone +33 1 64 62 35 00  
E-Mail info@sick.fr

**Great Britain**

Phone +44 (0)1727 831121  
E-Mail info@sick.co.uk

**India**

Phone +91-22-4033 8333  
E-Mail info@sick-india.com

**Israel**

Phone +972-4-6881000  
E-Mail info@sick-sensors.com

**Italia**

Phone +39 02 27 43 41  
E-Mail info@sick.it

**Japan**

Phone +81 (0)3 5309 2112  
E-Mail support@sick.jp

**Magyarország**

Phone +36 1 371 2680  
E-Mail office@sick.hu

**Nederland**

Phone +31 (0)30 229 25 44  
E-Mail info@sick.nl

**Norge**

Phone +47 67 81 50 00  
E-Mail sick@sick.no

**Österreich**

Phone +43 (0)22 36 62 28 8-0  
E-Mail office@sick.at

**Polska**

Phone +48 22 837 40 50  
E-Mail info@sick.pl

**România**

Phone +40 356 171 120  
E-Mail office@sick.ro

**Russia**

Phone +7-495-775-05-30  
E-Mail info@sick.ru

**Schweiz**

Phone +41 41 619 29 39  
E-Mail contact@sick.ch

**Singapore**

Phone +65 6744 3732  
E-Mail sales.gsg@sick.com

**Slovenija**

Phone +386 (0)1-47 69 990  
E-Mail office@sick.si

**South Africa**

Phone +27 11 472 3733  
E-Mail info@sickautomation.co.za

**South Korea**

Phone +82 2 786 6321/4  
E-Mail info@sickkorea.net

**Suomi**

Phone +358-9-25 15 800  
E-Mail sick@sick.fi

**Sverige**

Phone +46 10 110 10 00  
E-Mail info@sick.se

**Taiwan**

Phone +886 2 2375-6288  
E-Mail sales@sick.com.tw

**Türkiye**

Phone +90 (216) 528 50 00  
E-Mail info@sick.com.tr

**United Arab Emirates**

Phone +971 (0) 4 88 65 878  
E-Mail info@sick.ae

**USA/México**

Phone +1(952) 941-6780  
1 (800) 325-7425 – tollfree  
E-Mail info@sickusa.com

More representatives and agencies  
at [www.sick.com](http://www.sick.com)