



Incremental encoders
DFV60 measuring wheel encoder

DFV60A-22PC65536



Model Name > [DFV60A-22PC65536](#)
Part No. > [1051309](#)



Illustration may differ

At a glance

- Rotatable spring arm for universal use
- 300 mm wheel circumference with o-ring made from NBR70
- Mounting arm and measurement wheels made from aluminum
- Programmable output voltage, zero pulse position, zero pulse width and number of pulses
- Connection: radial M12 connector outlet or radial/axial cable outlet
- Electrical interfaces: 5V & 24V TTL/RS-422, 24 V HTL/push pull
- Remote zero setting possible

Your benefits

- Universal-use spring arm ensures fast and simple mounting
- The high level of spring tension enables use in harsh environmental conditions
- Reduced storage costs and downtime due to programmability
- Connector-in cable outlet in radial or axial direction enables customer-specific cable solutions
- Excellent concentricity even at high speeds
- Permanent and safe operation due to a high enclosure rating, temperature resistance and a long bearing lifetime
- Programmability via the PGT-08 programming software and the PGT-10-S display programming tool allow the encoder to be adapted flexibly and quickly according to customer needs
- Programmable zero pulse position simplifies installation



Performance

Measuring step deviation:	± 0.002 °
Initialization time:	30 ms
Error limits 'O' ring surface:	± 0.03 mm
Pulses per revolution:	65,536

Mechanical data

Mechanical interface:	2 measuring wheels, 'O' ring surface
Mass:	0.5 kg
Maximum operating speed:	3,000 U/min ¹⁾
Bearing lifetime:	3 x 10 ⁹ revolutions
Spring deflection spring arm:	40 mm
Preload spring arm:	20 mm

1) Self-warming 3.3 K/1,000 1/min, when applying note working temperature range

Electrical data

Electrical interface:	4.5 V ... 32 V, TTL/HTL programmable, Connector, M12, 8-pin, radial
Connection type:	Connector, M12, 8-pin, radial
Supply voltage:	4.5 V ... 32 V
Output current:	30 mA
Maximum output frequency:	820 kHz
Reference signal, number:	1
Reference signal, position:	90 °, electronically, gated with A and B
MTTFd: mean time to dangerous failure:	300 a (EN ISO 13849-1) ¹⁾

1) This product is a standard product and does not constitute a safety component as defined in the Machinery Directive.

Calculation based on nominal load of components, average ambient

temperature 40°C, frequency of use 8760 h/a. All

electronic failures are considered hazardous. For more information, see document no. 8015532.

Ambient data

EMC:	EN 61000-6-2, EN 61000-6-3
Protection class standard:	IEC 60529
Air humidity:	90 % ¹⁾
Working temperature range:	-20 °C ... +100 °C
Storage temperature range:	-40 °C ... +100 °C, without package
Resistance to shocks:	70 g, 6 ms (EN 60068-2-27)
Resistance to vibration:	30 g, 2,000 Hz ... 10 Hz (EN 60068-2-6)
Enclosure rating:	IP 65

1) Condensation of the optical scanning not permitted

Dimensional drawing

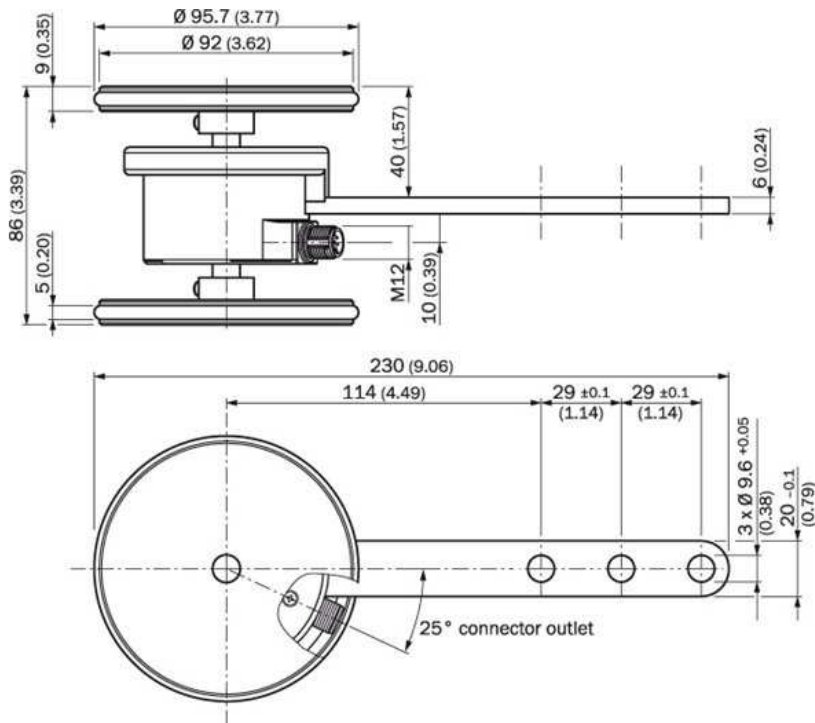

PIN assignment

Cable 8-core

View to the connector M12 fitted to the encoder body

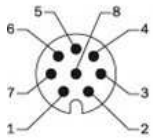

PIN, 8-pin, connector M12	Color of wires for encoders with cable outlet	Signal TTL, HTL	Explanation
1	Brown	\bar{A}	Signal line
2	White	A	Signal line
3	Black	\bar{B}	Signal line
4	Pink	B	Signal line
5	Yellow	\bar{Z}	Signal line
6	Lilac	Z	Signal line
7	Blue	GND	Ground connection of the encoder
8	Red	+U _s	Supply voltage (potential free to housing)
Screen	Screen	Screen	Screen connected to encoder housing. On the control side connected to earth.

Signalausgänge

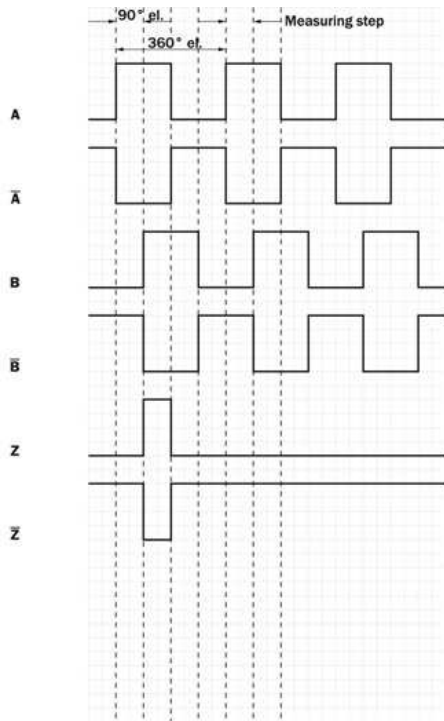

Australia

Phone +61 3 9457 0600
1800 33 48 02 – tollfree
E-Mail sales@sick.com.au

Belgium/Luxembourg

Phone +32 (0)2 466 55 66
E-Mail info@sick.be

Brasil

Phone +55 11 3215-4900
E-Mail marketing@sick.com.br

Canada

Phone +1 905 771 14 44
E-Mail information@sick.com

Česká republika

Phone +420 2 57 91 18 50
E-Mail sick@sick.cz

China

Phone +86 4000 121 000
E-Mail info.china@sick.net.cn
Phone +852-2153 6300
E-Mail ghk@sick.com.hk

Danmark

Phone +45 45 82 64 00
E-Mail sick@sick.dk

Deutschland

Phone +49 211 5301-301
E-Mail info@sick.de

España

Phone +34 93 480 31 00
E-Mail info@sick.es

France

Phone +33 1 64 62 35 00
E-Mail info@sick.fr

Great Britain

Phone +44 (0)1727 831121
E-Mail info@sick.co.uk

India

Phone +91-22-4033 8333
E-Mail info@sick-india.com

Israel

Phone +972-4-6881000
E-Mail info@sick-sensors.com

Italia

Phone +39 02 27 43 41
E-Mail info@sick.it

Japan

Phone +81 (0)3 5309 2112
E-Mail support@sick.jp

Magyarország

Phone +36 1 371 2680
E-Mail office@sick.hu

Nederland

Phone +31 (0)30 229 25 44
E-Mail info@sick.nl

Norge

Phone +47 67 81 50 00
E-Mail sick@sick.no

Österreich

Phone +43 (0)22 36 62 28 8-0
E-Mail office@sick.at

Polska

Phone +48 22 837 40 50
E-Mail info@sick.pl

România

Phone +40 356 171 120
E-Mail office@sick.ro

Russia

Phone +7-495-775-05-30
E-Mail info@sick.ru

Schweiz

Phone +41 41 619 29 39
E-Mail contact@sick.ch

Singapore

Phone +65 6744 3732
E-Mail sales.gsg@sick.com

Slovenija

Phone +386 (0)1-47 69 990
E-Mail office@sick.si

South Africa

Phone +27 11 472 3733
E-Mail info@sickautomation.co.za

South Korea

Phone +82 2 786 6321/4
E-Mail info@sickkorea.net

Suomi

Phone +358-9-25 15 800
E-Mail sick@sick.fi

Sverige

Phone +46 10 110 10 00
E-Mail info@sick.se

Taiwan

Phone +886 2 2375-6288
E-Mail sales@sick.com.tw

Türkiye

Phone +90 (216) 528 50 00
E-Mail info@sick.com.tr

United Arab Emirates

Phone +971 (0) 4 88 65 878
E-Mail info@sick.ae

USA/México

Phone +1(952) 941-6780
1 (800) 325-7425 – tollfree
E-Mail info@sickusa.com

More representatives and agencies
at www.sick.com