



Photoelectric sensors
W4S-3, Photoelectric proximity sensor,
Background suppression

WTB4S-3P3432S05



Model Name > [WTB4S-3P3432S05](#)
Part No. > [1051765](#)



Illustration may differ

At a glance

- Best background suppression in its class
- Setting either via teach-in pushbutton, 5-turn potentiometer cable or by IO-Link
- All models with PinPoint LED technology
- Versions with laser-like LED light spots
- High immunity to ambient light

Your benefits

- Less downtime due to reliable detection of all types of objects
- Laser-like light spot provides quick and easy alignment
- Smart machine design makes it possible to mount the sensor in the tightest spaces
- Reliable object detection due to best-in-class background suppression and high immunity to ambient light



Features

Sensor/detection principle:	Photoelectric proximity sensor, Background suppression
Dimensions (W x H x D):	12.2 mm x 41.8 mm x 17.3 mm
Housing design (light emission):	Rectangular
Sensing range max.:	3 mm ... 280 mm ¹⁾
Sensing range:	3 mm ... 280 mm ²⁾
Type of light:	Visible red light
Light source:	PinPoint LED ³⁾
Wave length:	650 nm
Teach-in:	Single teach-in button
Special features:	Small light spot diameter of 2 mm in 100 mm distance
Adjustment:	Teach-in
Light spot size (distance):	Ø 2 mm (100 mm)

^{1) 2)} Object with 90 % reflectance (referred to standard white DIN 5033) ³⁾ Average service life of 100,000 h at T_A = +25 °C

Mechanics/electronics

Supply voltage:	10 V DC ... 30 V DC ¹⁾
Ripple:	< 5 Vpp ²⁾
Power consumption:	≤ 20 mA ³⁾
Output type:	PNP
Output function:	Complementary

Switching mode:	Light/dark switching
Output current I _{max} ..:	≤ 100 mA
Response time:	< 0.5 ms ⁴⁾
Switching frequency:	1,000 Hz ⁵⁾
Connection type:	Cable with connector M12, 4-pin, 150 mm ⁶⁾
Cable material:	PVC
Conductor cross-section:	0.14 mm ²
Cable diameter:	Ø 3.4 mm
Circuit protection:::	A, C, D ^{7) 8) 9)}
Protection class:	III
Special device:	✓
Housing material:	ABS, Plastic
Optics material:	PMMA
Enclosure rating:	IP 67
Ambient operating temperature:	-40 °C ... 60 °C
Ambient storage temperature:	-40 °C ... 75 °C
UL File No.:	NRKH.E181493 & NRKH7.E181493

1) Limit values 2) May not exceed or fall short of V_S tolerances 3) Without load 4) Signal transit time with resistive load 5) With light/dark ratio 1:1 6) Do not bend below 0 °C 7) A = V_S connections reverse-polarity protected 8) C = interference suppression 9) D = outputs overcurrent and short-circuit protected

Dimensional drawing

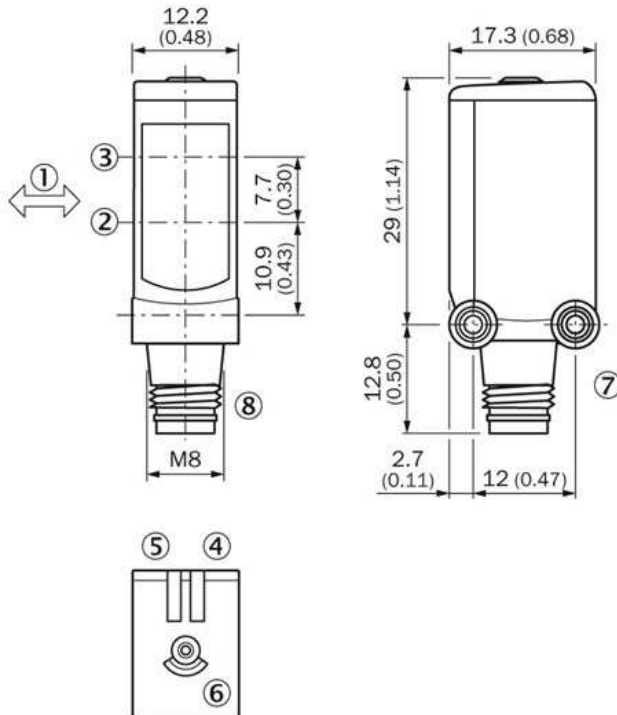

- [1] Standard direction of the material being scanned
- [2] Optical axis receiver
- [3] Optical axis sender
- [4] Status indicator LED green: power on
- [5] Status indicator LED, yellow: Status of received light beam
- [6] Teach-in button
- [7] Threaded mounting hole M3
- [8] Connection

Connection diagram

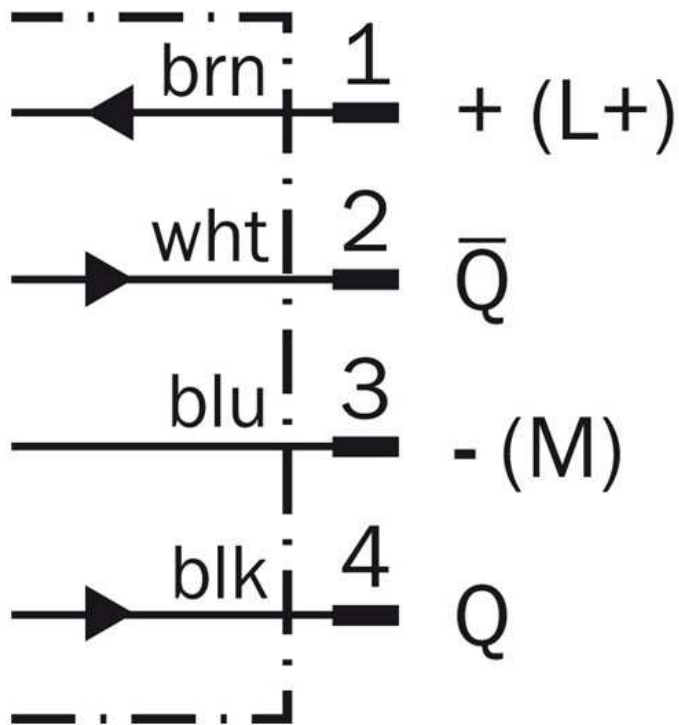

Characteristic curve

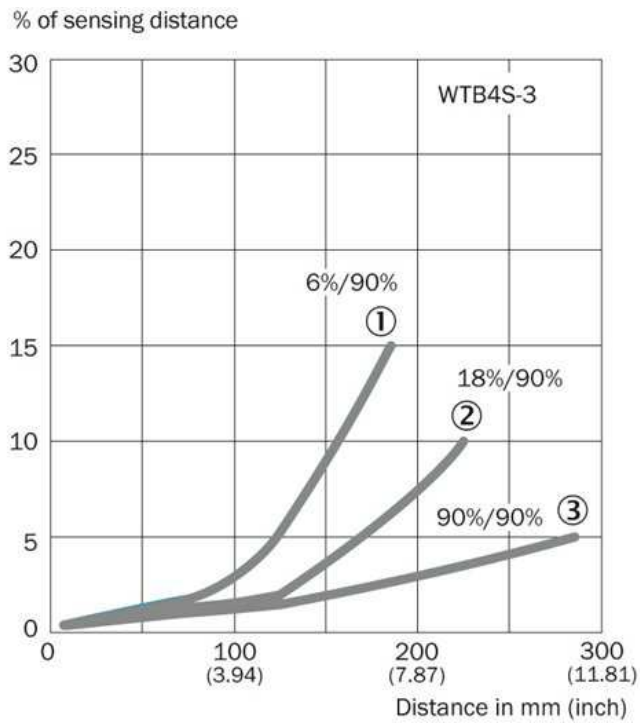

Connection type



Sensing range diagram

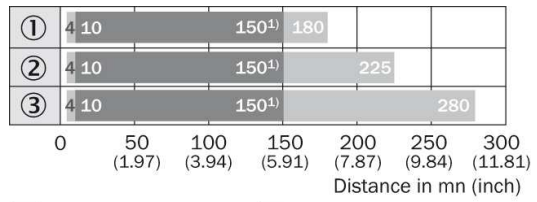

■ Operating distance ■ Sensing distance typ. max.

- ① Sensing distance on black, 6 % remission
- ② Sensing distance on grey, 18 % remission
- ③ Sensing distance on whitw, 90 % remission

¹⁾Due to the focus of the light spot at 100 mm (3.94 inch)

Australia

Phone +61 3 9457 0600
1800 33 48 02 – tollfree
E-Mail sales@sick.com.au

Belgium/Luxembourg

Phone +32 (0)2 466 55 66
E-Mail info@sick.be

Brasil

Phone +55 11 3215-4900
E-Mail marketing@sick.com.br

Canada

Phone +1 905 771 14 44
E-Mail information@sick.com

Česká republika

Phone +420 2 57 91 18 50
E-Mail sick@sick.cz

China

Phone +86 4000 121 000
E-Mail info.china@sick.net.cn
Phone +852-2153 6300
E-Mail ghk@sick.com.hk

Danmark

Phone +45 45 82 64 00
E-Mail sick@sick.dk

Deutschland

Phone +49 211 5301-301
E-Mail info@sick.de

España

Phone +34 93 480 31 00
E-Mail info@sick.es

France

Phone +33 1 64 62 35 00
E-Mail info@sick.fr

Great Britain

Phone +44 (0)1727 831121
E-Mail info@sick.co.uk

India

Phone +91-22-4033 8333
E-Mail info@sick-india.com

Israel

Phone +972-4-6881000
E-Mail info@sick-sensors.com

Italia

Phone +39 02 27 43 41
E-Mail info@sick.it

Japan

Phone +81 (0)3 5309 2112
E-Mail support@sick.jp

Magyarország

Phone +36 1 371 2680
E-Mail office@sick.hu

Nederland

Phone +31 (0)30 229 25 44
E-Mail info@sick.nl

Norge

Phone +47 67 81 50 00
E-Mail sick@sick.no

Österreich

Phone +43 (0)22 36 62 28 8-0
E-Mail office@sick.at

Polska

Phone +48 22 837 40 50
E-Mail info@sick.pl

România

Phone +40 356 171 120
E-Mail office@sick.ro

Russia

Phone +7-495-775-05-30
E-Mail info@sick.ru

Schweiz

Phone +41 41 619 29 39
E-Mail contact@sick.ch

Singapore

Phone +65 6744 3732
E-Mail sales.gsg@sick.com

Slovenija

Phone +386 (0)1-47 69 990
E-Mail office@sick.si

South Africa

Phone +27 11 472 3733
E-Mail info@sickautomation.co.za

South Korea

Phone +82 2 786 6321/4
E-Mail info@sickkorea.net

Suomi

Phone +358-9-25 15 800
E-Mail sick@sick.fi

Sverige

Phone +46 10 110 10 00
E-Mail info@sick.se

Taiwan

Phone +886 2 2375-6288
E-Mail sales@sick.com.tw

Türkiye

Phone +90 (216) 528 50 00
E-Mail info@sick.com.tr

United Arab Emirates

Phone +971 (0) 4 88 65 878
E-Mail info@sick.ae

USA/México

Phone +1(952) 941-6780
1 (800) 325-7425 – tollfree
E-Mail info@sickusa.com

More representatives and agencies
at www.sick.com