



Photoelectric sensors
W11-2, Through-beam photoelectric sensor

WSE11-2P1130



Model Name > **WSE11-2P1130**
Part No. > **1057572**



Illustration may differ

At a glance

- Through-beam photoelectric sensor
- Rugged housing for industrial use
- PinPoint LED technology with a highly visible light spot
- Space-saving plastic housing in chemically, thermally or mechanically resistant designs
- Dovetail mounting - standard mounting holes and oblong holes
- Highly visible 360° status LEDs
- Operating distance up to 20 m

Your benefits

- Custom ASIC provides reliable object detection, large sensing ranges and high reserve levels
- High immunity to optical interference reduces false readings and downtime
- PinPoint LED technology provides bright, small, precise light spots and enables quick and easy sensor alignment, first-class switching characteristics and reliable object detection
- Rugged housing design withstands harsh environments, reducing downtime and maintenance effort
- Highly visible 360° status LEDs provide quick and easy setup without additional personnel or costly training
- Easy installation using SICK accessories



Features

Sensor/detection principle:	Through-beam photoelectric sensor
Dimensions (W x H x D):	15.6 mm x 48.5 mm x 42 mm
Housing design (light emission):	Rectangular
Sensing range max.:	0 m ... 20 m
Sensing range:	0 m ... 15 m
Type of light:	Visible red light
Light source:	LED
Wave length:	633 nm
Angle of dispersion:	Ca. 1.5 °
Light spot size (distance):	Ø 220 mm (15 m)

Mechanics/electronics

Supply voltage:	10 V DC ... 30 V DC ¹⁾
Ripple:	≤ 5 Vpp ²⁾

Power consumption, sender:	≤ 25 mA ³⁾
Power consumption, receiver:	≤ 20 mA ⁴⁾
Output type:	PNP
Output function:	Complementary
Switching mode:	Light/dark switching
Signal voltage PNP HIGH/LOW:	U _v - 2.5 V / approx. 0 V
Output current I _{max} :	100 mA
Response time:	≤ 2.5 ms ⁵⁾
Switching frequency:	200 Hz ⁶⁾
Connection type:	Cable, 4-wire, 2 m ⁷⁾
Cable material:	PVC
Conductor cross-section:	0.25 mm ²
Circuit protection:::	A, C, D ^{8) 9) 10)}
Protection class:	II
Weight:	200 g
Housing material:	ABS, Plastic
Optics material:	PMMA
Enclosure rating:	IP 66 IP 67 IP 69K
Test input sender off:	TE to 0 V
Ambient operating temperature:	-30 °C ... 60 °C
Ambient storage temperature:	-40 °C ... 75 °C
UL File No.:	NRKH.E181493 & NRKH7.E181493

¹⁾ Limit values, operation in short-circuit protected network max. 8 A resistive load ⁶⁾ With light/dark ratio 1:1 ⁷⁾ Do not bend below 0 °C
²⁾ May not exceed or fall short of V_S tolerances ^{3) 4)} Without load ⁵⁾ Signal transit time with
⁸⁾ A = V_S connections reverse-polarity protected ⁹⁾ C = interference suppression ¹⁰⁾ D = outputs
 overcurrent and short-circuit protected

Dimensional drawing

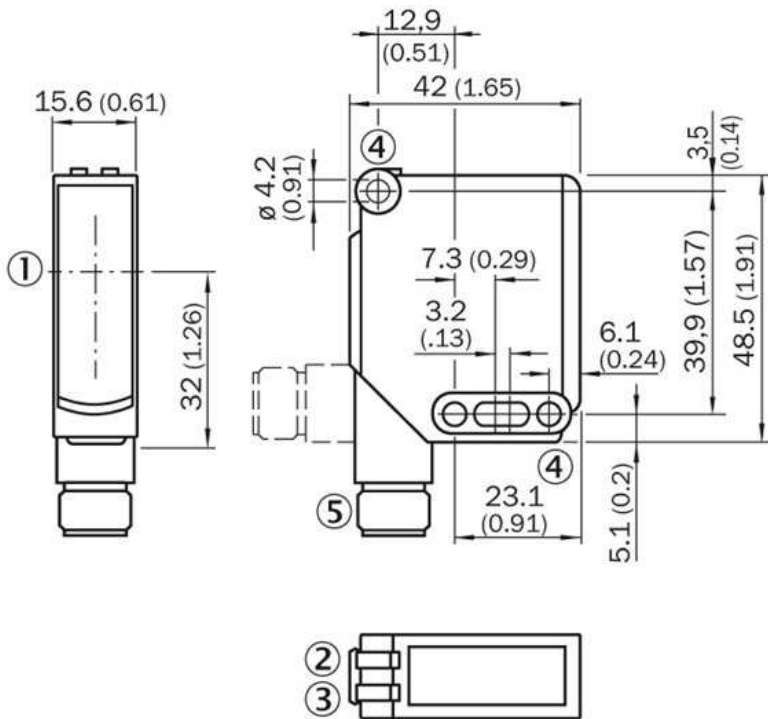

- [1] Center of optical axis
- [2] Status indicator LED green: power on
- [3] Status indicator LED, yellow: Status of received light beam
- [4] Mounting hole \varnothing 4.2 mm
- [5] M12 connector, 4-pin or cable

Adjustments possible

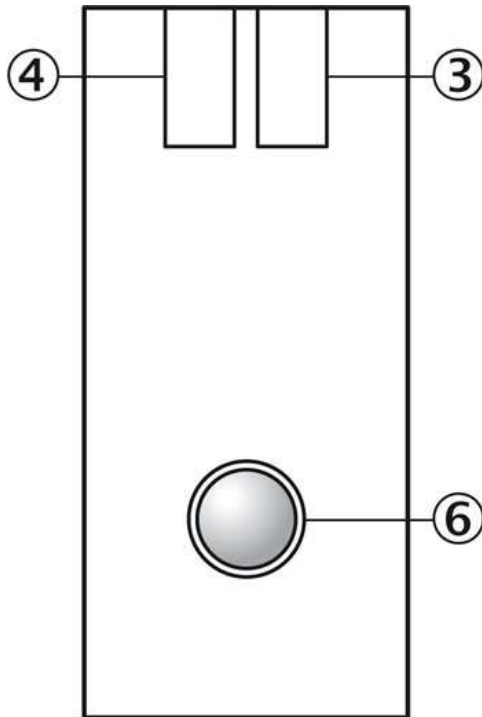

- [3] Status indicator LED green: power on
- [4] Status indicator LED, yellow: Status of received light beam
- [6] Adjustment sensing range: single teach button

Connection diagram

①

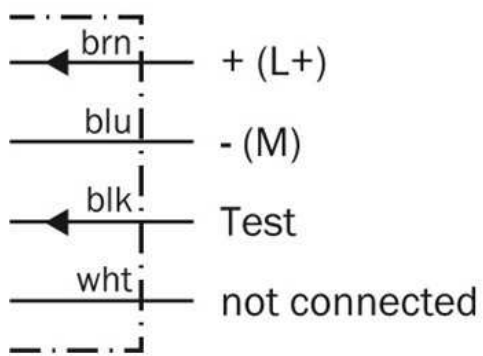

②

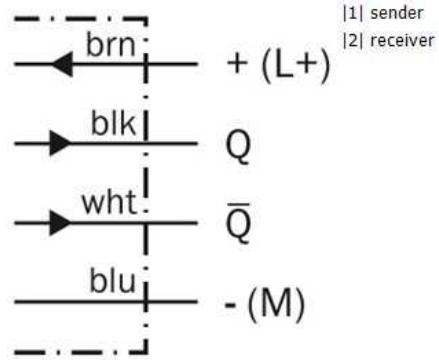

Connection type

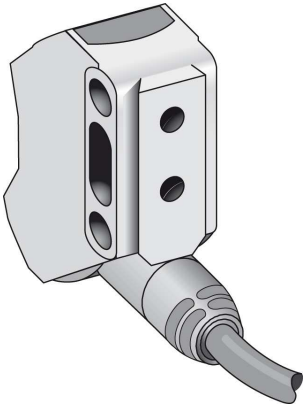

Australia

Phone +61 3 9457 0600
1800 33 48 02 – tollfree
E-Mail sales@sick.com.au

Belgium/Luxembourg

Phone +32 (0)2 466 55 66
E-Mail info@sick.be

Brasil

Phone +55 11 3215-4900
E-Mail marketing@sick.com.br

Canada

Phone +1 905 771 14 44
E-Mail information@sick.com

Česká republika

Phone +420 2 57 91 18 50
E-Mail sick@sick.cz

China

Phone +86 4000 121 000
E-Mail info.china@sick.net.cn
Phone +852-2153 6300
E-Mail ghk@sick.com.hk

Danmark

Phone +45 45 82 64 00
E-Mail sick@sick.dk

Deutschland

Phone +49 211 5301-301
E-Mail info@sick.de

España

Phone +34 93 480 31 00
E-Mail info@sick.es

France

Phone +33 1 64 62 35 00
E-Mail info@sick.fr

Great Britain

Phone +44 (0)1727 831121
E-Mail info@sick.co.uk

India

Phone +91-22-4033 8333
E-Mail info@sick-india.com

Israel

Phone +972-4-6881000
E-Mail info@sick-sensors.com

Italia

Phone +39 02 27 43 41
E-Mail info@sick.it

Japan

Phone +81 (0)3 5309 2112
E-Mail support@sick.jp

Magyarország

Phone +36 1 371 2680
E-Mail office@sick.hu

Nederland

Phone +31 (0)30 229 25 44
E-Mail info@sick.nl

Norge

Phone +47 67 81 50 00
E-Mail sick@sick.no

Österreich

Phone +43 (0)22 36 62 28 8-0
E-Mail office@sick.at

Polska

Phone +48 22 837 40 50
E-Mail info@sick.pl

România

Phone +40 356 171 120
E-Mail office@sick.ro

Russia

Phone +7-495-775-05-30
E-Mail info@sick.ru

Schweiz

Phone +41 41 619 29 39
E-Mail contact@sick.ch

Singapore

Phone +65 6744 3732
E-Mail sales.gsg@sick.com

Slovenija

Phone +386 (0)1-47 69 990
E-Mail office@sick.si

South Africa

Phone +27 11 472 3733
E-Mail info@sickautomation.co.za

South Korea

Phone +82 2 786 6321/4
E-Mail info@sickkorea.net

Suomi

Phone +358-9-25 15 800
E-Mail sick@sick.fi

Sverige

Phone +46 10 110 10 00
E-Mail info@sick.se

Taiwan

Phone +886 2 2375-6288
E-Mail sales@sick.com.tw

Türkiye

Phone +90 (216) 528 50 00
E-Mail info@sick.com.tr

United Arab Emirates

Phone +971 (0) 4 88 65 878
E-Mail info@sick.ae

USA/México

Phone +1(952) 941-6780
1 (800) 325-7425 – tollfree
E-Mail info@sickusa.com

More representatives and agencies
at www.sick.com