



Inductive proximity sensors
Inductive MultiTask sensors, SAM M18

IMC18-07BPDZCOSA05



Model Name > [IMC18-07BPDZC0SA05](#)
Part No. > [1061987](#)



At a glance

- Speed and acceleration monitoring
- Monitoring range: 6 to 12,000 pulses/min. and 0.1 to 2 pulses/sec.²
- Switching and pulse output
- Intelligent start-up delay
- Speed monitoring can be flexibly configured via two thresholds
- Flexible sensor settings, monitoring, extended diagnostics, and visualization thanks to IO-Link
- Sensing range: 7 mm flush
- Type M18

Your benefits

- Speed-independent detection of speed changes
- Faster detection of speed changes than conventional speed monitors
- No readjustment after speed changes necessary
- Precise and convenient configuration via software
- IO-Link provides easy data access from the PLC
- No time-consuming, individual configuration of start-up delay feature necessary
- Reliable output signal thanks to adjustable speed thresholds (hysteresis)
- No expensive counter cards necessary in PLC



Features

Design:	Cylindrical
Thread size:	M18 x 1
Sensing range Sn:	7 mm
Assured sensing range Sa:	5.6 mm
Installation type:	Flush
Output type:	PNP
Output function:	NO
Electrical wiring:	DC 4-wire
Enclosure rating:	IP 67 ¹⁾
Connection type:	Connector M12, 4-pin
Output Q Imp:	Pulse output (The pulse sequence corresponds to the damping frequency)
Output Q:	Output type (dependant on the adjusted threshold)
Speed range, adjustable via two thresholds:	6...12,000 impulses/min ²⁾
Acceleration range, adjustable:	0.1...2 impulses/sec ³⁾

Time delay, adjustable: Mode 0: No start-up delay
 Mode 1: 0...254 sec., adjustable
 Mode 2: When reaching the upper threshold

1) According to EN 60529 2) Up to a max. pulse sequence of 12,000 pulses/min 3) Up to a max. pulse sequence of 1.200 pulses/min

Mechanics/electronics

Supply voltage:	10 V DC ... 30 V DC
Ripple:	≤ 10 %
Voltage drop:	≤ 2.5 V ¹⁾
Power consumption:	≤ 35 mA ²⁾
Hysteresis:	5 % ... 15 % ³⁾
Repeatability:	≤ 2 % ^{4) 5)}
Temperature drift (of Sr):	± 10 %
EMC:	According to EN 60947-5-2
Output current I _a :	≤ 100 mA
Wire-break protection:	0
Short-circuit protection:	✓
Reverse polarity protection:	✓
Power-up pulse protection:	✓
Shock and vibration resistance:	30 g, 11 ms/10 Hz ... 55 Hz, 1 mm
Ambient temperature operation:	-25 °C ... +75 °C
Housing material:	Metal, Nickel-plated brass
Housing cap material:	Plastic, PA6
Housing length:	69 mm
Thread length:	52 mm
Tightening torque, max.:	≤ 40 Nm
Status indicator QImp:	LED, yellow
Status indicator Q:	LED, blau
Minimum response time:	Mode acceleration monitoring 1 sec, Mode speed monitoring 50 ms
Factory setting:	Operating mode: acceleration monitoring, Threshold acceleration: 1 pulse/sec ² , Start-up delay mode: time delay, Upper/lower threshold speed: 200/300 pulses/min, Time delay: 5 sec
Fieldbus integration:	IO-Link V1.0
Mode:	COM 2 (38k4)
Cycle time:	5 ms
Process data length:	16 Bit
Process data structure:	1 bit pulse output, 1 bit switching output, 14 bit measured value

1) At I_a max 2) Without load 3) Of S_n 4) U_b and T_a constant 5) Of Sr

Reduction factors

Note:	The values are reference values which may vary
Carbon steel St37 (Fe):	1
Stainless steel (V2A, 304):	0.8
Copper (Cu):	0.4
Aluminum (Al):	0.45
Brass (Br):	0.4

Installation note

B:	18 mm
C:	18 mm

D: 18 mm
F: 56 mm
Remark: Associated graphic see "Installation"

Installation note

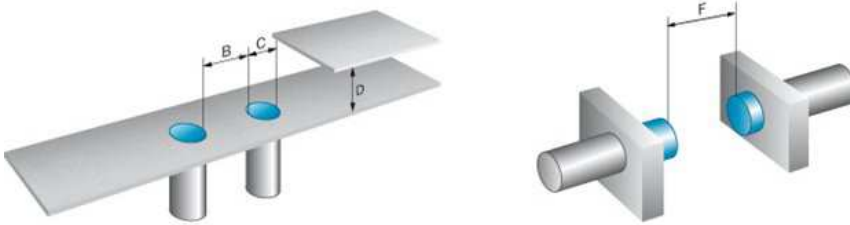

Dimensional drawing

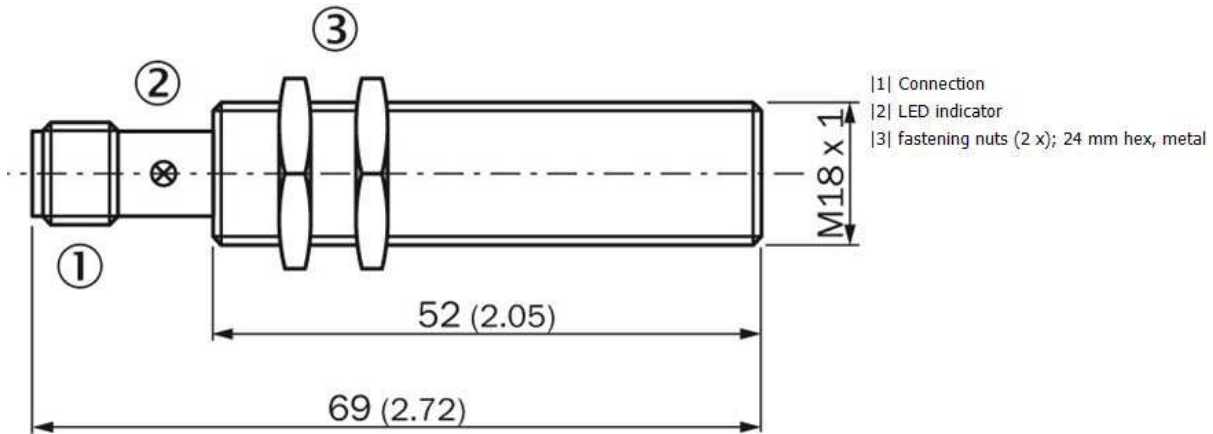

Connection diagram

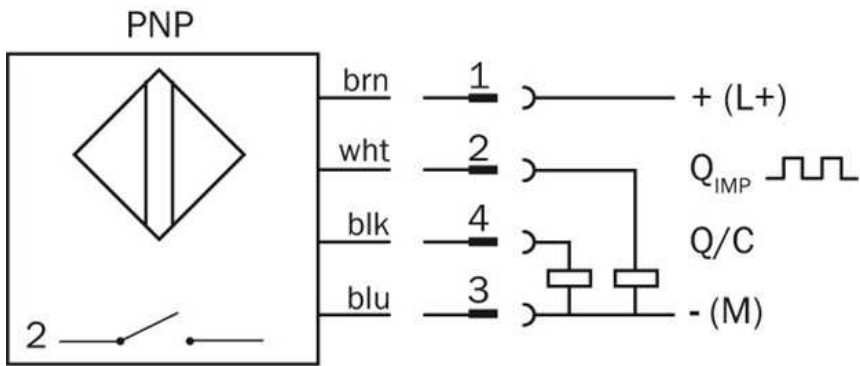

Connection type

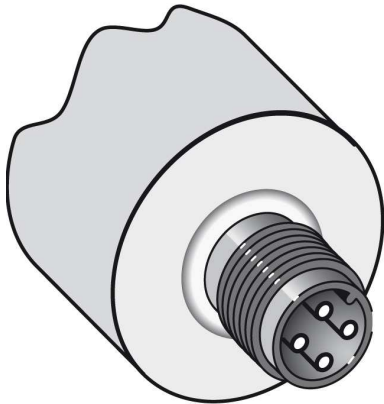

Australia

Phone +61 3 9457 0600
1800 33 48 02 – tollfree
E-Mail sales@sick.com.au

Belgium/Luxembourg

Phone +32 (0)2 466 55 66
E-Mail info@sick.be

Brasil

Phone +55 11 3215-4900
E-Mail marketing@sick.com.br

Canada

Phone +1 905 771 14 44
E-Mail information@sick.com

Česká republika

Phone +420 2 57 91 18 50
E-Mail sick@sick.cz

China

Phone +86 4000 121 000
E-Mail info.china@sick.net.cn
Phone +852-2153 6300
E-Mail ghk@sick.com.hk

Danmark

Phone +45 45 82 64 00
E-Mail sick@sick.dk

Deutschland

Phone +49 211 5301-301
E-Mail info@sick.de

España

Phone +34 93 480 31 00
E-Mail info@sick.es

France

Phone +33 1 64 62 35 00
E-Mail info@sick.fr

Great Britain

Phone +44 (0)1727 831121
E-Mail info@sick.co.uk

India

Phone +91-22-4033 8333
E-Mail info@sick-india.com

Israel

Phone +972-4-6881000
E-Mail info@sick-sensors.com

Italia

Phone +39 02 27 43 41
E-Mail info@sick.it

Japan

Phone +81 (0)3 5309 2112
E-Mail support@sick.jp

Magyarország

Phone +36 1 371 2680
E-Mail office@sick.hu

Nederland

Phone +31 (0)30 229 25 44
E-Mail info@sick.nl

Norge

Phone +47 67 81 50 00
E-Mail sick@sick.no

Österreich

Phone +43 (0)22 36 62 28 8-0
E-Mail office@sick.at

Polska

Phone +48 22 837 40 50
E-Mail info@sick.pl

România

Phone +40 356 171 120
E-Mail office@sick.ro

Russia

Phone +7-495-775-05-30
E-Mail info@sick.ru

Schweiz

Phone +41 41 619 29 39
E-Mail contact@sick.ch

Singapore

Phone +65 6744 3732
E-Mail sales.gsg@sick.com

Slovenija

Phone +386 (0)1-47 69 990
E-Mail office@sick.si

South Africa

Phone +27 11 472 3733
E-Mail info@sickautomation.co.za

South Korea

Phone +82 2 786 6321/4
E-Mail info@sickkorea.net

Suomi

Phone +358-9-25 15 800
E-Mail sick@sick.fi

Sverige

Phone +46 10 110 10 00
E-Mail info@sick.se

Taiwan

Phone +886 2 2375-6288
E-Mail sales@sick.com.tw

Türkiye

Phone +90 (216) 528 50 00
E-Mail info@sick.com.tr

United Arab Emirates

Phone +971 (0) 4 88 65 878
E-Mail info@sick.ae

USA/México

Phone +1(952) 941-6780
1 (800) 325-7425 – tollfree
E-Mail info@sickusa.com

More representatives and agencies
at www.sick.com