



Photoelectric sensors
W9L-3, Photoelectric proximity sensor,
Background suppression

WTB9M4L-3P3461



Model Name > [WTB9M4L-3P3461](#)
Part No. > [1063663](#)

At a glance

- Tough VISTAL™ housing
- Precise laser light spot
- Laser classes 1 and 2 available
- Optimized SICK ASIC technology with second transmission LED
- Connections: M8 and M12 plugs, cable as well as cable with plug
- M4 hole pattern

Your benefits

- Precise detection of small objects and object features
- Detection of objects even through small openings
- Less machine downtime due to stable VISTAL™ housing as well as impressive suppression of optical interference
- The longest sensing ranges in its class
- Best-in-class background suppression
- Wide range of connection options
- Multiple mounting options
- Highly visible light spot simplifies alignment



Illustration may differ



Features

Sensor/detection principle:	Photoelectric proximity sensor, Background suppression
Dimensions (W x H x D):	12.2 mm x 52.2 mm x 23.6 mm
Housing design (light emission):	Rectangular
Mounting hole:	M4
Sensing range max.:	25 mm ... 300 mm ¹⁾
Sensing range:	25 mm ... 300 mm ²⁾
Type of light:	Visible red light
Light source:	Laser ³⁾
Laser class:	1, 1 (IEC 60825-1/CDRH 21 CFR 1040.10 & 1040.11)
Wave length:	650 nm
Adjustment:	Potentiometer, 5 turns
Light spot size (distance):	Ø 1 mm (170 mm)

^{1) 2)} Object with 90 % reflectance (referred to standard white, DIN 5033) ³⁾ Average service life 50,000 h at T_A = +25 °C

Mechanics/electronics

Supply voltage:	10 V DC ... 30 V DC ¹⁾
Ripple:	< 5 Vpp ²⁾
Power consumption:	≤ 30 mA ³⁾
Output type:	PNP ⁴⁾
Output function:	Complementary
Switching mode:	Light/dark switching ⁵⁾
Output current I _{max.} :	≤ 100 mA
Response time:	≤ 0.5 ms ⁶⁾
Switching frequency:	1,000 Hz ⁷⁾
Connection type:	Cable with connector M12, 4-pin
Circuit protection:::	A, B, C ^{8) 9) 10)}
Protection class:	III
Weight:	13 g
Optics material:	PMMA
Enclosure rating:	IP 66 IP 67 IP 69K
Ambient temperature operation:	-10 °C ... +50 °C
Ambient storage temperature:	-30 °C ... +70 °C
Ambient operating temperature extended:::	-30 °C ... +55 °C ^{11) 12)}
UL File No.:	NRKH.E181493
Housing material:	Plastic, VISTAL

1) Limit values, operation in short-circuit protected network max. 8 A
2) May not exceed or fall short of V_S tolerances
3) Without load
4) 5) Q = light switching
6) Signal
7) With light/dark ratio 1:1
8) A = V_S connections reverse-polarity protected
9) B = inputs and output reverse-polarity protected
10) C = interference suppression
11) As of T_a = 50 °C, a max. supply voltage V_{max.} = 24 V and a max. load current I_{max.} = 50 mA is permitted
12) Using the sensor below T_a = -10 °C is possible, if the sensor is turned on at T_a > -10 °C, then the environment cools down and the sensor is not disconnected from the supply voltage during the whole time. It is not allowed to turn on the sensor below T_a = -10 °C

Dimensional drawing

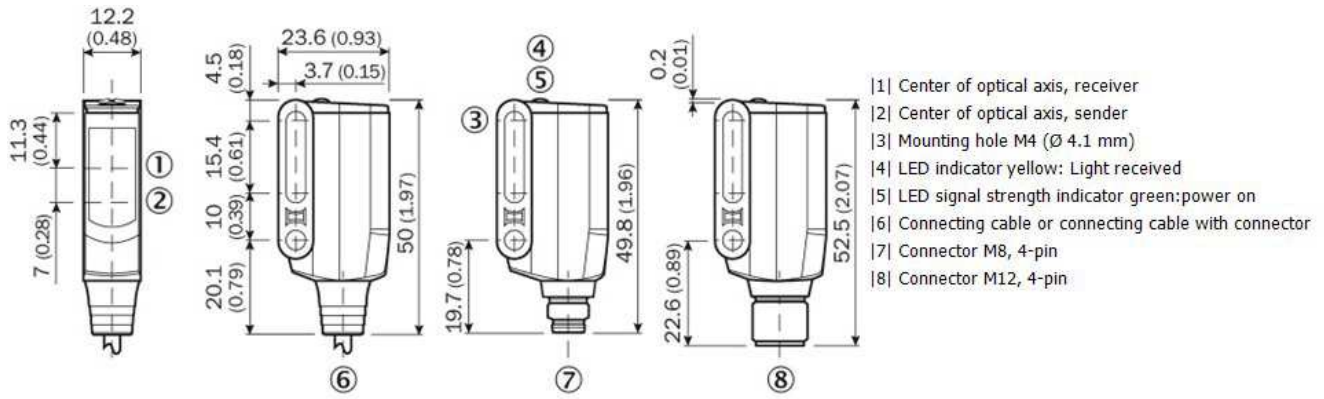

Adjustments possible

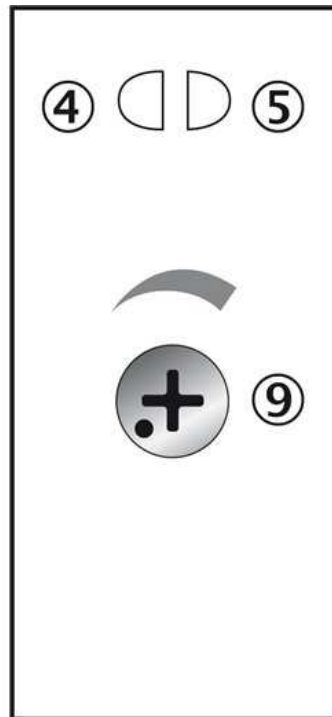

- |4| LED indicator yellow: Light received
- |5| LED signal strength indicator green:power on
- |9| Sensing range adjustment

Connection diagram

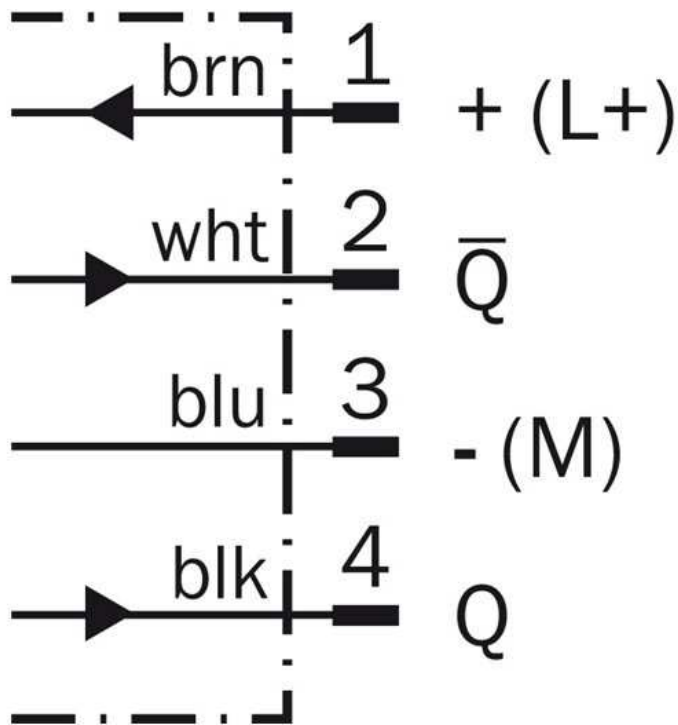

Characteristic curve

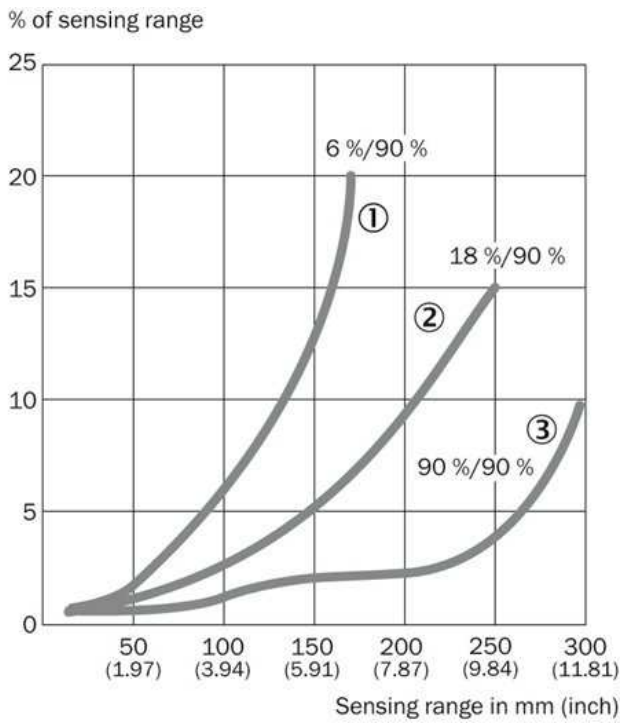

- [1] Sensing range on black, 6 % remission
- [2] Sensing range on gray, 18 % remission
- [3] Sensing range on white, 90 % remission

Light spot size

Radius in mm (inch)

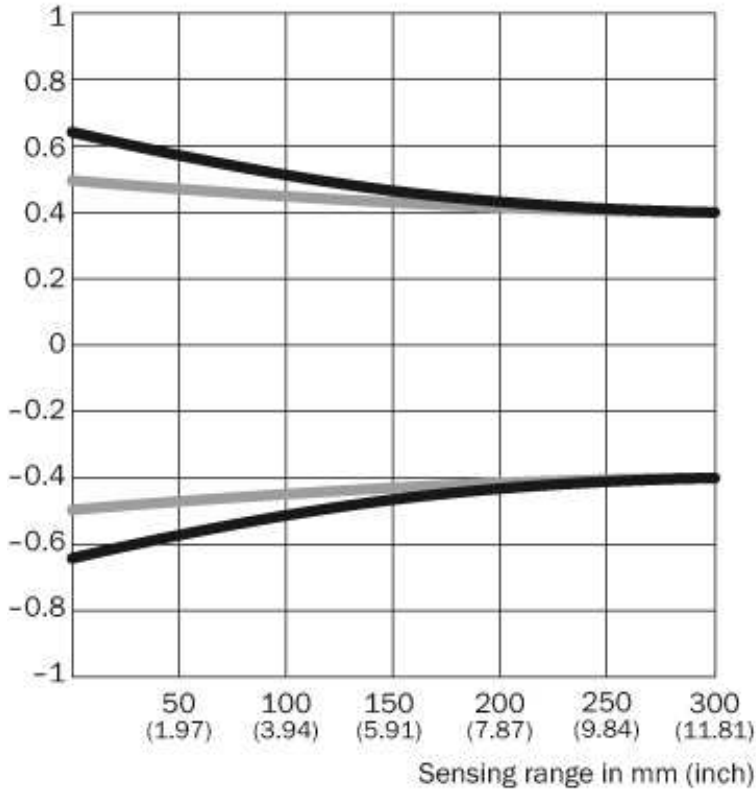

Dimensions in mm (inch)

Sensing range	Vertical	Horizontal
50 mm (1.97)	1.2 (0.05)	1.0 (0.04)
100 mm (3.94)	1.1 (0.04)	1.0 (0.04)
200 mm (7.87)	0.9 (0.04)	0.9 (0.04)
300 mm (11.81)	0.8 (0.03)	0.8 (0.03)

Vertical
 Horizontal

Sensing range diagram

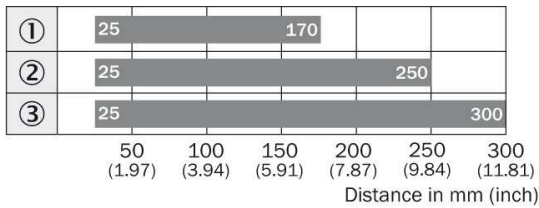

■ Sensing range typ. max.

Australia

Phone +61 3 9457 0600
1800 33 48 02 – tollfree
E-Mail sales@sick.com.au

Belgium/Luxembourg

Phone +32 (0)2 466 55 66
E-Mail info@sick.be

Brasil

Phone +55 11 3215-4900
E-Mail marketing@sick.com.br

Canada

Phone +1 905 771 14 44
E-Mail information@sick.com

Česká republika

Phone +420 2 57 91 18 50
E-Mail sick@sick.cz

China

Phone +86 4000 121 000
E-Mail info.china@sick.net.cn
Phone +852-2153 6300
E-Mail ghk@sick.com.hk

Danmark

Phone +45 45 82 64 00
E-Mail sick@sick.dk

Deutschland

Phone +49 211 5301-301
E-Mail info@sick.de

España

Phone +34 93 480 31 00
E-Mail info@sick.es

France

Phone +33 1 64 62 35 00
E-Mail info@sick.fr

Great Britain

Phone +44 (0)1727 831121
E-Mail info@sick.co.uk

India

Phone +91-22-4033 8333
E-Mail info@sick-india.com

Israel

Phone +972-4-6881000
E-Mail info@sick-sensors.com

Italia

Phone +39 02 27 43 41
E-Mail info@sick.it

Japan

Phone +81 (0)3 5309 2112
E-Mail support@sick.jp

Magyarország

Phone +36 1 371 2680
E-Mail office@sick.hu

Nederland

Phone +31 (0)30 229 25 44
E-Mail info@sick.nl

Norge

Phone +47 67 81 50 00
E-Mail sick@sick.no

Österreich

Phone +43 (0)22 36 62 28 8-0
E-Mail office@sick.at

Polska

Phone +48 22 837 40 50
E-Mail info@sick.pl

România

Phone +40 356 171 120
E-Mail office@sick.ro

Russia

Phone +7-495-775-05-30
E-Mail info@sick.ru

Schweiz

Phone +41 41 619 29 39
E-Mail contact@sick.ch

Singapore

Phone +65 6744 3732
E-Mail sales.gsg@sick.com

Slovenija

Phone +386 (0)1-47 69 990
E-Mail office@sick.si

South Africa

Phone +27 11 472 3733
E-Mail info@sickautomation.co.za

South Korea

Phone +82 2 786 6321/4
E-Mail info@sickkorea.net

Suomi

Phone +358-9-25 15 800
E-Mail sick@sick.fi

Sverige

Phone +46 10 110 10 00
E-Mail info@sick.se

Taiwan

Phone +886 2 2375-6288
E-Mail sales@sick.com.tw

Türkiye

Phone +90 (216) 528 50 00
E-Mail info@sick.com.tr

United Arab Emirates

Phone +971 (0) 4 88 65 878
E-Mail info@sick.ae

USA/México

Phone +1(952) 941-6780
1 (800) 325-7425 – tollfree
E-Mail info@sickusa.com

More representatives and agencies
at www.sick.com