



Photoelectric sensors
GR18, Through-beam photoelectric sensor

GRSE18-N1147



Model Name > GRSE18-N1147
Part No. > 1066558



Illustration may differ

At a glance

- Economical M18 cylindrical sensors with standard housing design
- Two different housing types made of plastic and metal with straight optical output
- Very bright and highly visible PinPoint LEDs
- Highly visible status indicator
- IP 67 enclosure rating

Your benefits

- A whole range of mounting options thanks to the different housing types
- Simple alignment and precise detection using PinPoint LEDs
- Easy to mount with simple M18 hole mounting. No special mounting brackets required.
- Rugged and reliable operation due to proven SICK sensing technology
- Clearly visible status display reduces setup time and maintenance time



Features

Sensor/detection principle:	Through-beam photoelectric sensor
Housing design (light emission):	Cylindrical, straight
Optical axis:	axial
Sensing range max.:	0 m ... 15 m
Sensing range:	0 m ... 10 m
Type of light:	Visible red light
Light source:	PinPoint LED ¹⁾
Wave length:	650 nm
Light spot size (distance):	Ø 250 mm (10 m)

¹⁾ Average service life of 100,000 h at T_A = +25 °C

Mechanics/electronics

Supply voltage:	10 V DC ... 30 V DC ¹⁾
Ripple:	± 5 Vpp ²⁾
Power consumption:	≤ 30 mA
Output type:	NPN
Output function:	Complementary
Switching mode:	Light/dark switching
Output current I _{max.} :	100 mA ³⁾
Response time:	< 500 µs ⁴⁾

Switching frequency:	1,000 Hz ⁵⁾
Electrical connection:	Cable, 4-wire, 2 m ⁶⁾
Cable material:	PVC
Circuit protection:::	A, B, D ^{7) 8) 9)}
Protection class:	III
Special device:	-
Enclosure rating:	IP 67
Items supplied:	Fastening nuts (4 x)
EMC:	EN 60947-5-2
Test input:	-
Ambient operating temperature:	-25 °C ... +55 °C ¹⁰⁾
Ambient storage temperature:	-40 °C ... +70 °C
UL File No.:	E348498
Signal voltage NPN HIGH/LOW:	Approx. $V_S / \leq 3 V$
Housing material:	Plastic

¹⁾ Limit values, operation in short-circuit protected network max. 8 A ²⁾ May not exceed or fall short of V_S tolerances ³⁾ At $V_S > 24 V$ or ambient temperature $> 49 °C$, I_A max = 50 mA ⁴⁾ Signal transit time with resistive load ⁵⁾ With light/dark ratio 1:1 ⁶⁾ Do not bend below 0 °C ⁷⁾ A = V_S connections reverse-polarity protected ⁸⁾ B = inputs and output reverse-polarity protected ⁹⁾ D = outputs overcurrent and short-circuit protected ¹⁰⁾ At $U_V \leq 24V$ and I_A

Dimensional drawing

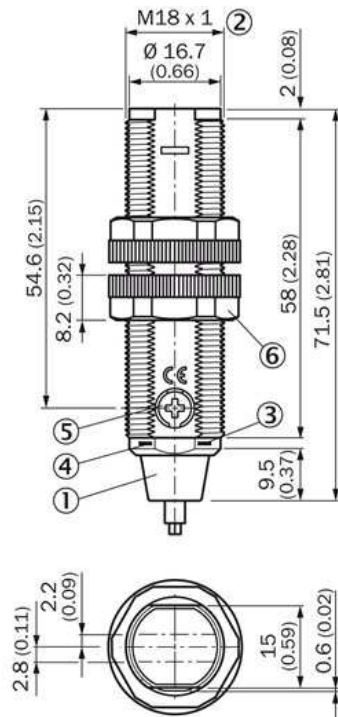

- |1| Connection cable 2 m
- |2| Threaded mounting hole M18 x 1
- |3| LED indicator yellow
- |4| LED indicator green
- |5| Sensitivity control; Potentiometer 270°
- |6| fastening nuts (2 x); width across 22, plastic

Connection diagram

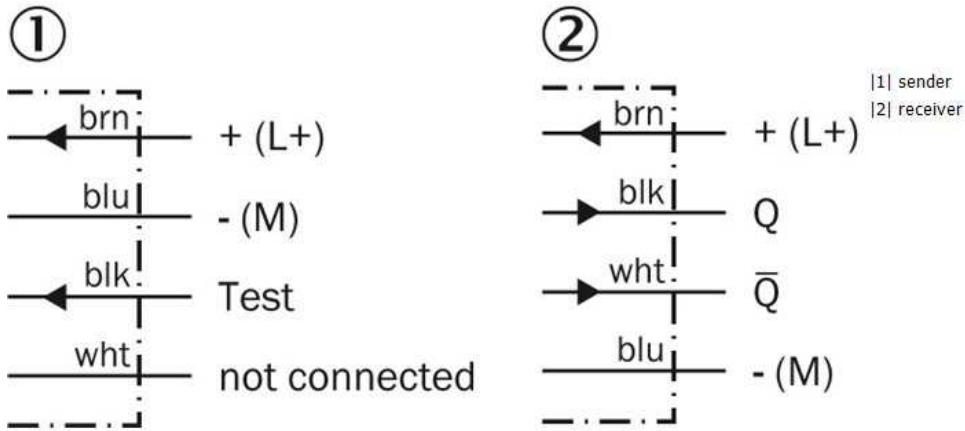

Characteristic curve

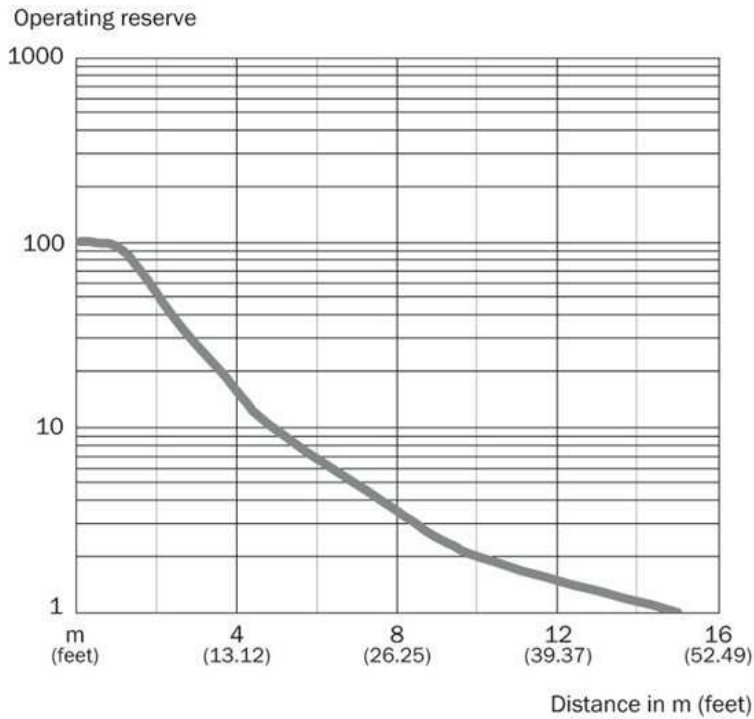

Sensing range diagram

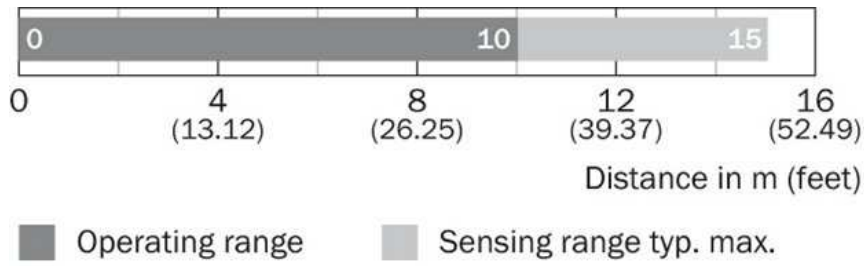

Light spot size

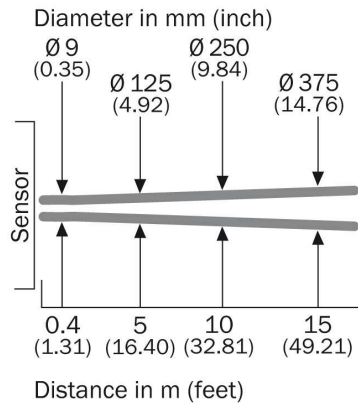

Australia

Phone +61 3 9457 0600
1800 33 48 02 – tollfree
E-Mail sales@sick.com.au

Belgium/Luxembourg

Phone +32 (0)2 466 55 66
E-Mail info@sick.be

Brasil

Phone +55 11 3215-4900
E-Mail marketing@sick.com.br

Canada

Phone +1 905 771 14 44
E-Mail information@sick.com

Česká republika

Phone +420 2 57 91 18 50
E-Mail sick@sick.cz

China

Phone +86 4000 121 000
E-Mail info.china@sick.net.cn
Phone +852-2153 6300
E-Mail ghk@sick.com.hk

Danmark

Phone +45 45 82 64 00
E-Mail sick@sick.dk

Deutschland

Phone +49 211 5301-301
E-Mail info@sick.de

España

Phone +34 93 480 31 00
E-Mail info@sick.es

France

Phone +33 1 64 62 35 00
E-Mail info@sick.fr

Great Britain

Phone +44 (0)1727 831121
E-Mail info@sick.co.uk

India

Phone +91-22-4033 8333
E-Mail info@sick-india.com

Israel

Phone +972-4-6881000
E-Mail info@sick-sensors.com

Italia

Phone +39 02 27 43 41
E-Mail info@sick.it

Japan

Phone +81 (0)3 5309 2112
E-Mail support@sick.jp

Magyarország

Phone +36 1 371 2680
E-Mail office@sick.hu

Nederland

Phone +31 (0)30 229 25 44
E-Mail info@sick.nl

Norge

Phone +47 67 81 50 00
E-Mail sick@sick.no

Österreich

Phone +43 (0)22 36 62 28 8-0
E-Mail office@sick.at

Polska

Phone +48 22 837 40 50
E-Mail info@sick.pl

România

Phone +40 356 171 120
E-Mail office@sick.ro

Russia

Phone +7-495-775-05-30
E-Mail info@sick.ru

Schweiz

Phone +41 41 619 29 39
E-Mail contact@sick.ch

Singapore

Phone +65 6744 3732
E-Mail sales.gsg@sick.com

Slovenija

Phone +386 (0)1-47 69 990
E-Mail office@sick.si

South Africa

Phone +27 11 472 3733
E-Mail info@sickautomation.co.za

South Korea

Phone +82 2 786 6321/4
E-Mail info@sickkorea.net

Suomi

Phone +358-9-25 15 800
E-Mail sick@sick.fi

Sverige

Phone +46 10 110 10 00
E-Mail info@sick.se

Taiwan

Phone +886 2 2375-6288
E-Mail sales@sick.com.tw

Türkiye

Phone +90 (216) 528 50 00
E-Mail info@sick.com.tr

United Arab Emirates

Phone +971 (0) 4 88 65 878
E-Mail info@sick.ae

USA/México

Phone +1(952) 941-6780
1 (800) 325-7425 – tollfree
E-Mail info@sickusa.com

More representatives and agencies
at www.sick.com