



Photoelectric sensors
W4S-3, Photoelectric proximity sensor,
Background suppression

WTB4SC-3P2262A70



Model Name > [WTB4SC-3P2262A70](#)
Part No. > [1067756](#)



Illustration may differ

At a glance

- Best background suppression in its class
- Setting either via teach-in pushbutton, 5-turn potentiometer cable or by IO-Link
- All models with PinPoint LED technology
- Versions with laser-like LED light spots
- High immunity to ambient light

Your benefits

- Less downtime due to reliable detection of all types of objects
- Laser-like light spot provides quick and easy alignment
- Smart machine design makes it possible to mount the sensor in the tightest spaces
- Reliable object detection due to best-in-class background suppression and high immunity to ambient light



Features

Sensor/detection principle:	Photoelectric proximity sensor, Background suppression
Dimensions (W x H x D):	12.2 mm x 41.8 mm x 17.3 mm
Housing design (light emission):	Rectangular
Sensing range max.:	4 mm ... 180 mm ¹⁾
Sensing range:	10 mm ... 180 mm ²⁾
Type of light:	Visible red light
Light source:	PinPoint LED ³⁾
Wave length:	650 nm
Adjustment:	Single teach-in button
Light spot size (distance):	Ø 6.5 mm (150 mm)
IO-Link functions:	Advanced functions, Standard functions
IO-Link advanced functions:	Decentralized debouncing, Time measurement/timer
Time measurement accuracy:::	IOL: - 0,9 ... + 0,9 ms ± 0,5 % of time measurement value, SIO Direct: ---, SIO Logic: - 0,7 ... + 0,7 ms ± 0,5 % of time measurement value ^{4) 5) 6) 7) 8) 9)}
Min. Time between two process events (switches):::	IOL: 900 µs, SIO Direct: ---, SIO Logic: 700 µs ^{10) 11) 12)}
Max. Debounce Range:::	IOL: 30.000 ms, SIO Direct: ---, SIO Logic: 30.000 ms
Time measurement accuracy (e.g. accuracy for time measurement):	IOL: - 5,9 ... + 5,9 ms, SIO Direct: ---, SIO Logic: - 5,7 ... + 5,7 ms

^{1) 2)} Object with 90 % reflectance (referred to standard white, DIN 5033) ³⁾ Average service life of 100,000 h at T_A = +25 °C ^{4) 7) 10)} SIO Direct: Sensor operation in standard I/O mode without IO-Link communication and without usage of sensor-internal logic or timing parameters. ^{5) 8) 11)} SIO Logic: Sensor operation in standard I/O mode without IO-Link communication. Sensor-internal logic or timing parameters plus Automation Functions used. ^{6) 9) 12)} IOL: Sensor operation with full IO-Link

communication and usage of logic, timing and Automation Function parameters.

Mechanics/electronics

Supply voltage:	10 V DC ... 30 V DC ¹⁾
Residual ripple:	< 5 Vpp ²⁾
Power consumption:	≤ 30 mA ³⁾
Output type:	PNP
Switching mode:	Light/dark switching
Output current I _{max} :	≤ 100 mA
Electrical connection:	Connector M8, 4-pin
Circuit protection::::	A, B, C, D ^{4) 5) 6) 7)}
Protection class:	III
Weight:	20 g
IO-Link:	✓
Optics material:	PMMA
Enclosure rating:	IP 67 IP 66
Ambient operating temperature:	-40 °C ... +60 °C
Ambient storage temperature:	-40 °C ... +75 °C
UL File No.:	NRKH.E181493 & NRKH7.E181493
Housing material:	ABS, Plastic
Response time Q/ on Pin 2:	280 μs ... 410 μs ⁸⁾
Switching frequency Q \ on Pin2:	1,000 Hz
Repeatability Q/ on Pin 2::	130 μs
IO-Link version:	1.0
Transmission rate:	COM2

With light/dark ratio 1:1, valid for Q \ on Pin2, if configured with software; Valid for Q / on Pin2, if configured with software;

¹⁾ Limit values, operation in short-circuit protected network max. 8 A ²⁾ May not exceed or fall short of V_S tolerances ³⁾ Without load ⁴⁾ A = V_S connections reverse-polarity protected ⁵⁾ B = inputs and output reverse-polarity protected ⁶⁾ C = interference suppression ⁷⁾ D = outputs overcurrent and short-circuit protected ⁸⁾ Signal transit time with resistive load

Dimensional drawing

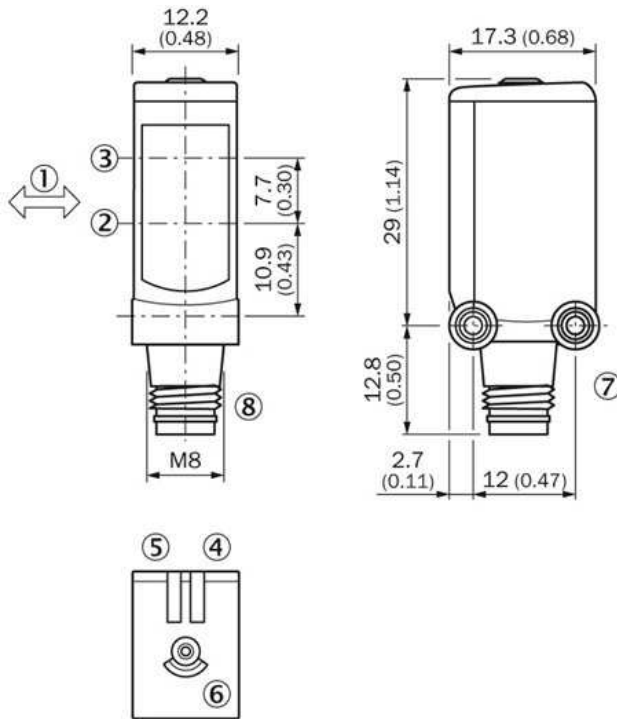

- |1| Standard direction of the material being detected
- |2| Optical axis receiver
- |3| Optical axis sender
- |4| Status indicator LED green: power on
- |5| Status indicator LED, yellow: Status of received light beam
- |6| Teach-in button
- |7| Threaded mounting hole M3
- |8| Connection

Connection diagram

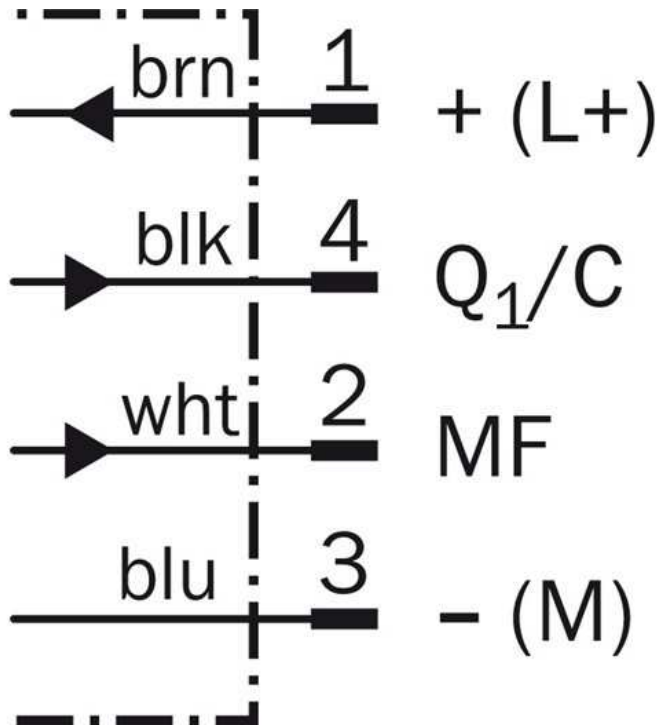

Characteristic curve

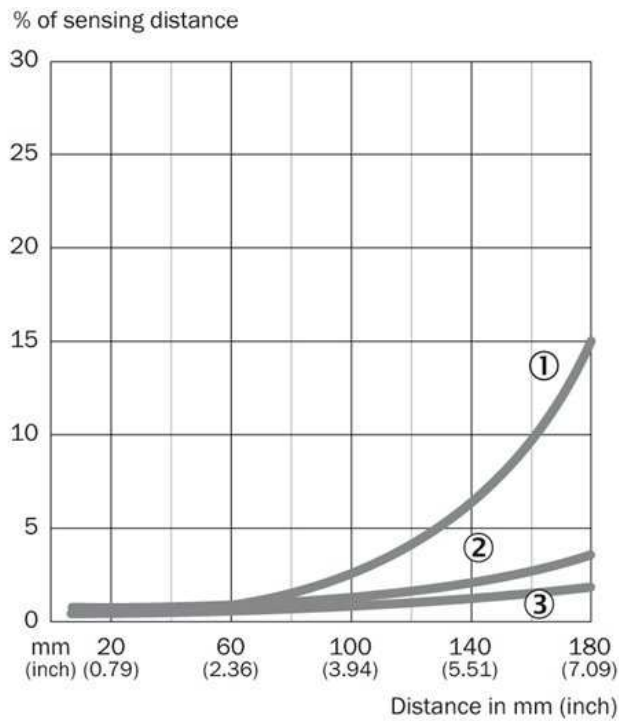

- |1| Sensing range on black, 6 % remission
- |2| Sensing range on gray, 18 % remission
- |3| Sensing range on white, 90 % remission

Sensing range diagram

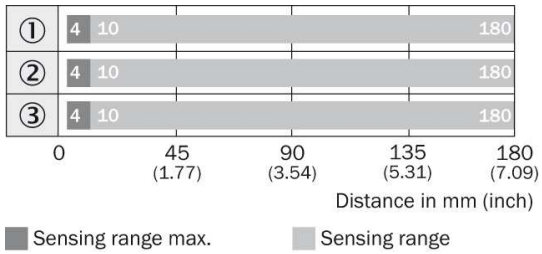

Australia

Phone +61 3 9457 0600
1800 33 48 02 – tollfree
E-Mail sales@sick.com.au

Belgium/Luxembourg

Phone +32 (0)2 466 55 66
E-Mail info@sick.be

Brasil

Phone +55 11 3215-4900
E-Mail marketing@sick.com.br

Canada

Phone +1 905 771 14 44
E-Mail information@sick.com

Česká republika

Phone +420 2 57 91 18 50
E-Mail sick@sick.cz

China

Phone +86 4000 121 000
E-Mail info.china@sick.net.cn
Phone +852-2153 6300
E-Mail ghk@sick.com.hk

Danmark

Phone +45 45 82 64 00
E-Mail sick@sick.dk

Deutschland

Phone +49 211 5301-301
E-Mail info@sick.de

España

Phone +34 93 480 31 00
E-Mail info@sick.es

France

Phone +33 1 64 62 35 00
E-Mail info@sick.fr

Great Britain

Phone +44 (0)1727 831121
E-Mail info@sick.co.uk

India

Phone +91-22-4033 8333
E-Mail info@sick-india.com

Israel

Phone +972-4-6881000
E-Mail info@sick-sensors.com

Italia

Phone +39 02 27 43 41
E-Mail info@sick.it

Japan

Phone +81 (0)3 5309 2112
E-Mail support@sick.jp

Magyarország

Phone +36 1 371 2680
E-Mail office@sick.hu

Nederland

Phone +31 (0)30 229 25 44
E-Mail info@sick.nl

Norge

Phone +47 67 81 50 00
E-Mail sick@sick.no

Österreich

Phone +43 (0)22 36 62 28 8-0
E-Mail office@sick.at

Polska

Phone +48 22 837 40 50
E-Mail info@sick.pl

România

Phone +40 356 171 120
E-Mail office@sick.ro

Russia

Phone +7-495-775-05-30
E-Mail info@sick.ru

Schweiz

Phone +41 41 619 29 39
E-Mail contact@sick.ch

Singapore

Phone +65 6744 3732
E-Mail sales.gsg@sick.com

Slovenija

Phone +386 (0)1-47 69 990
E-Mail office@sick.si

South Africa

Phone +27 11 472 3733
E-Mail info@sickautomation.co.za

South Korea

Phone +82 2 786 6321/4
E-Mail info@sickkorea.net

Suomi

Phone +358-9-25 15 800
E-Mail sick@sick.fi

Sverige

Phone +46 10 110 10 00
E-Mail info@sick.se

Taiwan

Phone +886 2 2375-6288
E-Mail sales@sick.com.tw

Türkiye

Phone +90 (216) 528 50 00
E-Mail info@sick.com.tr

United Arab Emirates

Phone +971 (0) 4 88 65 878
E-Mail info@sick.ae

USA/México

Phone +1(952) 941-6780
1 (800) 325-7425 – tollfree
E-Mail info@sickusa.com

More representatives and agencies
at www.sick.com