



Photoelectric sensors  
W4S-3, Photoelectric retro-reflective sensor,  
autocollimation

WL4SC-3P2232A71



**Model Name** > [WL4SC-3P2232A71](#)  
**Part No.** > [1067761](#)



*Illustration may differ*

**At a glance**

- Single-lens autocollimation optics
- All models with PinPoint LED technology provides a small intense, light spot
- Maximum sensing range of 5 m
- Key lock function, remote teach
- Diagnostics messages (contamination and short-circuit)
- Flexible sensor settings, monitoring, extended diagnostics, and visualization thanks to IO-Link
- Programmable functions as debouncing and time-measurement are included

**Your benefits**

- Quick and easy alignment due to the PinPoint LED's small, well-defined, intense light spot
- Single-lens autocollimation optics sees through small gaps and bore holes, enabling efficient machine integration
- Simple monitoring of detection quality
- Key lock function and parameter download prevent incorrect settings
- IO-Link provides easy data access from the PLC
- Quick and easy configuration
- Quick and easy integration using function blocks
- Easy device replacement and identification



**Features**

Sensor/detection principle:	Photoelectric retro-reflective sensor, autocollimation
Dimensions (W x H x D):	12.2 mm x 41.8 mm x 17.3 mm
Housing design (light emission):	Rectangular
Sensing range max.:	0 m ... 5 m <sup>1)</sup>
Sensing range:	0 m ... 3 m <sup>2)</sup>
Type of light:	Visible red light
Light source:	PinPoint LED <sup>3)</sup>
Wave length:	650 nm
Adjustment:	Single teach-in button
Light spot size (distance):	Ø 45 mm (1.5 m)
IO-Link functions:	Advanced functions, Standard functions
IO-Link advanced functions:	Decentralized debouncing, High speed counter <sup>4) 5) 6)</sup>
Min. Time between two process events (switches):::	IO-Link: 700 µs, SIO Direct: ---, SIO Logic: 500 µs <sup>7) 8) 9)</sup>
Max. Debounce Range:::	IO-Link: 30.000 ms, SIO Direct: ---, SIO Logic: 30.000 ms <sup>10) 11) 12)</sup>
CounterReset:::	IO-Link: 1,5 ms, SIO Direct: ---, SIO Logic: 1,5 ms

1) 2) PL80A 3) Average service life: 100,000 h at  $T_U = +25\text{ °C}$  4) 7) 10) SIO Direct: Sensor operation in standard I/O mode without IO-Link communication and without usage of sensor-internal logic or timing parameters (set to "direct"/"deactivated"). 5) 8) 11) SIO Logic: Sensor operation in standard I/O mode without IO-Link communication. Sensor-internal logic or timing parameters plus Automation Functions used. 6) 9) 12) IOL: Sensor operation with full IO-Link communication and usage of logic, timing and Automation Function parameters.

## Mechanics/electronics

Supply voltage:	10 V DC ... 30 V DC <sup>1)</sup>
Residual ripple::	$\leq 5\text{ Vpp}$ <sup>2) 3)</sup>
Power consumption:	$\leq 20\text{ mA}$ <sup>4)</sup>
Output type:	PNP
Switching mode:	Light/dark switching
Output current I <sub>max</sub> ::	$\leq 100\text{ mA}$
Electrical connection:	Connector M8, 4-pin
Circuit protection:::	A, B, C, D <sup>5) 6) 7) 8)</sup>
Protection class:	III
Weight:	30 g
Polarisation filter:	✓
IO-Link:	✓
Special device:	-
Optics material:	PMMA
Enclosure rating:	IP 67 IP 66
Ambient operating temperature:	-40 °C ... +60 °C
Ambient storage temperature:	-40 °C ... +75 °C
UL File No.:	NRKH.E181493 & NRKH7.E181493
Housing material:	ABS, Plastic
Response time Q/ on Pin 2::	300 µs ... 450 µs <sup>9) 10)</sup>
Switching frequency Q \ on Pin2:	1,000 Hz
Repeatability Q/ on Pin 2::	150 µs
IO-Link version:	1.0
Transmission rate:	COM2

With light/dark ratio 1:1, valid for Q \ on Pin2, if configured with software; Valid for Q \ on Pin2, if configured with software;

1) Limit values when operated in short-circuit protected network: max. 8 A 2) 3) May not exceed or fall below U tolerances 4) Without load 5)  $A = V_S$  connections reverse-polarity protected 6) B = inputs and output reverse-polarity protected 7) C = interference suppression 8) D = outputs overcurrent and short-circuit protected 9)  
Signal transit time with resistive load <sup>10)</sup> Valid for Q \ on Pin2, if configured with software

**Dimensional drawing**

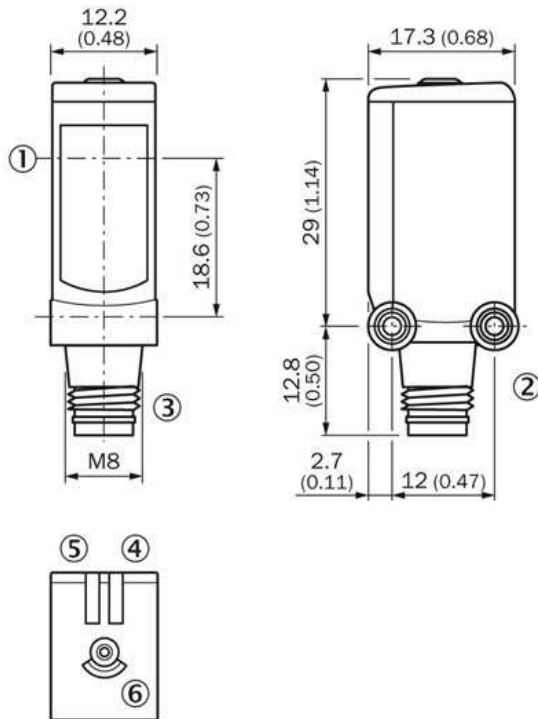

- |1| Center of optical axis
- |2| Threaded mounting hole M3
- |3| Connection
- |4| Status indicator LED green: supply voltage on
- |5| LED indicator orange: status of received light beam
- |6| Teach-in button

**Connection diagram**

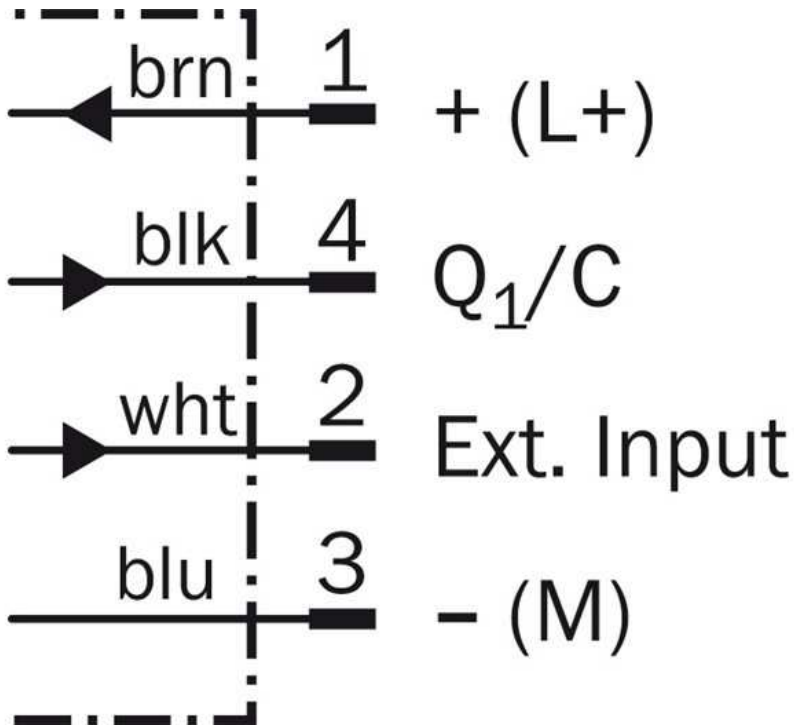

## Characteristic curve

Operating reserve

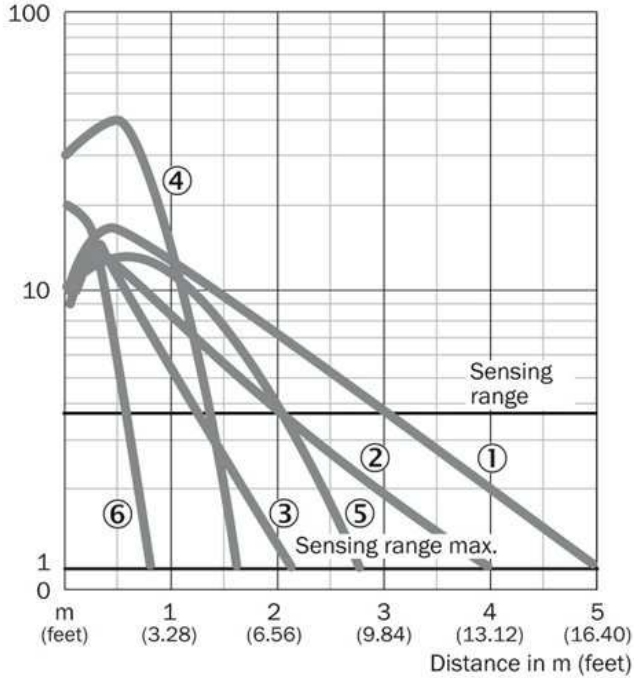

- |1| PL80A
- |2| PL40A
- |3| PL20A
- |4| PL10F
- |5| P250 CHEM
- |6| REF-IRF-56

## Sensing range diagram

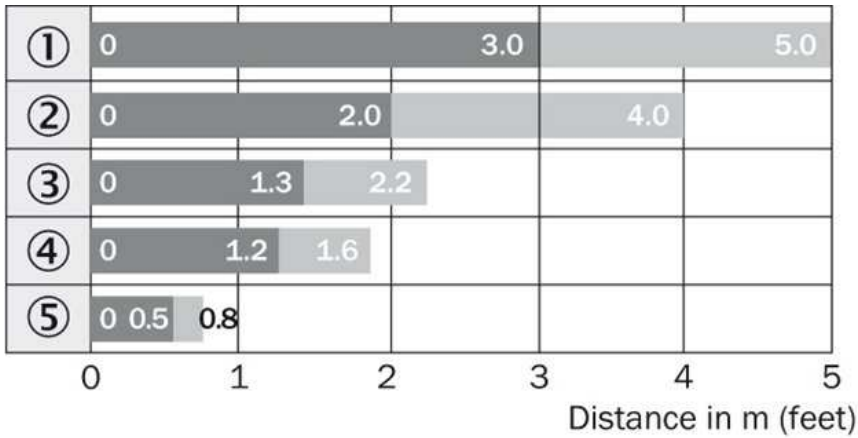

- |1| PL80A
- |2| PL40A
- |3| PL20A
- |4| PL10F
- |5| REF-IRF-56

■ Sensing range      ■ Sensing range max.

### Connection type

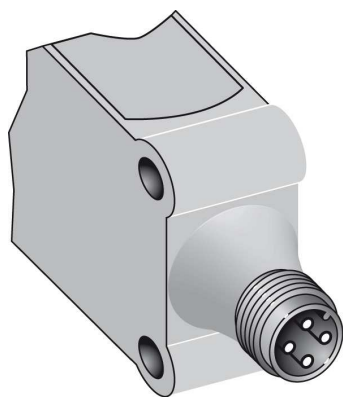

### Light spot size

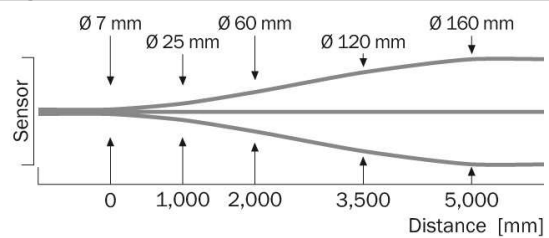

**Australia**

Phone +61 3 9457 0600  
1800 33 48 02 – tollfree  
E-Mail sales@sick.com.au

**Belgium/Luxembourg**

Phone +32 (0)2 466 55 66  
E-Mail info@sick.be

**Brasil**

Phone +55 11 3215-4900  
E-Mail marketing@sick.com.br

**Canada**

Phone +1 905 771 14 44  
E-Mail information@sick.com

**Česká republika**

Phone +420 2 57 91 18 50  
E-Mail sick@sick.cz

**China**

Phone +86 4000 121 000  
E-Mail info.china@sick.net.cn  
Phone +852-2153 6300  
E-Mail ghk@sick.com.hk

**Danmark**

Phone +45 45 82 64 00  
E-Mail sick@sick.dk

**Deutschland**

Phone +49 211 5301-301  
E-Mail info@sick.de

**España**

Phone +34 93 480 31 00  
E-Mail info@sick.es

**France**

Phone +33 1 64 62 35 00  
E-Mail info@sick.fr

**Great Britain**

Phone +44 (0)1727 831121  
E-Mail info@sick.co.uk

**India**

Phone +91-22-4033 8333  
E-Mail info@sick-india.com

**Israel**

Phone +972-4-6881000  
E-Mail info@sick-sensors.com

**Italia**

Phone +39 02 27 43 41  
E-Mail info@sick.it

**Japan**

Phone +81 (0)3 5309 2112  
E-Mail support@sick.jp

**Magyarország**

Phone +36 1 371 2680  
E-Mail office@sick.hu

**Nederland**

Phone +31 (0)30 229 25 44  
E-Mail info@sick.nl

**Norge**

Phone +47 67 81 50 00  
E-Mail sick@sick.no

**Österreich**

Phone +43 (0)22 36 62 28 8-0  
E-Mail office@sick.at

**Polska**

Phone +48 22 837 40 50  
E-Mail info@sick.pl

**România**

Phone +40 356 171 120  
E-Mail office@sick.ro

**Russia**

Phone +7-495-775-05-30  
E-Mail info@sick.ru

**Schweiz**

Phone +41 41 619 29 39  
E-Mail contact@sick.ch

**Singapore**

Phone +65 6744 3732  
E-Mail sales.gsg@sick.com

**Slovenija**

Phone +386 (0)1-47 69 990  
E-Mail office@sick.si

**South Africa**

Phone +27 11 472 3733  
E-Mail info@sickautomation.co.za

**South Korea**

Phone +82 2 786 6321/4  
E-Mail info@sickkorea.net

**Suomi**

Phone +358-9-25 15 800  
E-Mail sick@sick.fi

**Sverige**

Phone +46 10 110 10 00  
E-Mail info@sick.se

**Taiwan**

Phone +886 2 2375-6288  
E-Mail sales@sick.com.tw

**Türkiye**

Phone +90 (216) 528 50 00  
E-Mail info@sick.com.tr

**United Arab Emirates**

Phone +971 (0) 4 88 65 878  
E-Mail info@sick.ae

**USA/México**

Phone +1(952) 941-6780  
1 (800) 325-7425 – tollfree  
E-Mail info@sickusa.com

More representatives and agencies  
at [www.sick.com](http://www.sick.com)