



Photoelectric sensors
W4S-3 Glass, Photoelectric retro-reflective
sensor, autocollimation

WLG4SC-3P3232B01



Model Name > [WLG4SC-3P3232B01](#)
Part No. > [1070334](#)



Illustration may differ

At a glance

- Continuous threshold adaption of the switching threshold compensates for environmental changes
- Single-lens autocollimation optics
- PinPoint LED technology with a small, highly visible, well-defined light spot enables high reserve levels when using small reflectors
- Flexible sensor settings, monitoring, extended diagnostics, and visualization thanks to IO-Link

Your benefits

- Optimal detection of any kind of transparent object
- Less downtime due to a Continuous Threshold Adaption which compensates for changing environmental conditions, including temperature, dust and drift effects
- IO-Link provides easy data access from the PLC
- Quick and easy configuration
- Quick and easy integration using function blocks
- Easy device replacement and identification



Features

Sensor/detection principle:	Photoelectric retro-reflective sensor, autocollimation
Dimensions (W x H x D):	12.2 mm x 41.8 mm x 17.3 mm
Housing design (light emission):	Rectangular
Sensing range max.:	0 m ... 5 m ¹⁾
Sensing range:	0 m ... 3 m ²⁾
Type of light:	Visible red light
Light source:	PinPoint LED ³⁾
Wave length:	650 nm
Special features:	Continuous threshold adaption on - time based, Parameter presettings: Transparent object mode; Switch-on threshold 50% (2 - 5 sec teach-in), Functions compatible with WLG4SC-3P2232A91
Adjustment:	Single teach-in button
Light spot size (distance):	Ø 45 mm (1.5 m)
Continuous threshold adaption:	✓
IO-Link functions:	Advanced functions, Standard functions
IO-Link advanced functions:	Decentralized debouncing, Time stamp
Gen. Response Time:::	IOL: ---, SIO Direct: 300 µs ... 450 µs, SIO Logic: 750 µs ... 900 µs ^{4) 5) 6)}
Gen. Repeatability:::	IOL: ---, SIO Direct: 150 µs, SIO Logic: 150 µs ^{7) 8) 9)}

Min. Time between two process events (switches):: IOL: 750 µs, SIO Direct: 450 µs, SIO Logic: 450 µs ^{10) 11) 12)}
 Max. Debounce Range:: IOL: 52 ms, SIO Direct: ---, SIO Logic: 52 ms ^{13) 14) 15)}
 Max. TimeStamp Buffer: IOL: 8, SIO Direct: ---, SIO Logic: ---
 Max. TimeStamp Range: IOL: 260 ms, SIO Direct: ---, SIO Logic: ---
 TimeStampAccuracy:: IOL: - 0,9 ... + 0,9 ms ± 0,5 % of time measurement value, SIO Direct: ---, SIO Logic: --- ^{16) 17) 18)}

1) 2) PL80A 3) Average service life of 100,000 h at T_A = +25 °C 4) 7) 10) 13) 16) SIO Direct: Sensor operation in standard I/O mode without IO-Link communication and without usage of sensor-internal logic or timing parameters (set to "direct"/"deactivated"). ^{5) 8) 11) 14) 17)} SIO Logic: Sensor operation in standard I/O mode without IO-Link communication. Sensor-internal logic or timing parameters plus Automation Functions used. ^{6) 9) 12) 15) 18)} IOL: Sensor operation with full IO-Link communication and usage of logic, timing and Automation Function parameters.

Mechanics/electronics

Supply voltage: 10 V DC ... 30 V DC ¹⁾
 Residual ripple:: < 5 Vpp ^{2) 3)}
 Power consumption: ≤ 20 mA ⁴⁾
 Output type: PNP
 Switching mode: Light/dark switching
 Output current I_{max}:: ≤ 100 mA
 Switching frequency: 1,000 Hz ⁵⁾
 Attenuation along light beam: > 8 %
 Electrical connection: Cable with connector M8, 4-pin, 100 mm
 Circuit protection::: A, B, C, D ^{6) 7) 8) 9)}
 Protection class: III
 Weight: 30 g
 Polarisation filter: ✓
 IO-Link: ✓
 Optics material: PMMA
 Enclosure rating: IP 67
 IP 66
 Special feature: Detection of transparent objects
 Ambient operating temperature: -40 °C ... +60 °C
 Ambient storage temperature: -40 °C ... +75 °C
 UL File No.: NRKH.E181493 & NRKH7.E181493
 Housing material: ABS, Plastic
 Response time Q/ on Pin 2:: 300 µs ... 450 µs ^{10) 11)}
 Switching frequency Q \ on Pin2: 1,000 Hz
 Repeatability Q/ on Pin 2:: 150 µs
 IO-Link version: 1.0

With light/dark ratio 1:1, valid for Q \ on Pin2, if configured with software;

1) Limit values, operation in short-circuit protected network max. 8 A ^{2) 3)} May not exceed or fall short of V_S tolerances ⁴⁾ Without load ⁵⁾ With light/dark ratio 1:1, valid for Q \ on Pin2, if configured with software ⁶⁾ A = V_S connections reverse-polarity protected ⁷⁾ B = inputs and output reverse-polarity protected ⁸⁾ C = interference suppression ⁹⁾ D = outputs overcurrent and short-circuit protected ¹⁰⁾ Signal transit time with resistive load ¹¹⁾ Valid for Q \ on Pin2, if configured with software

Dimensional drawing

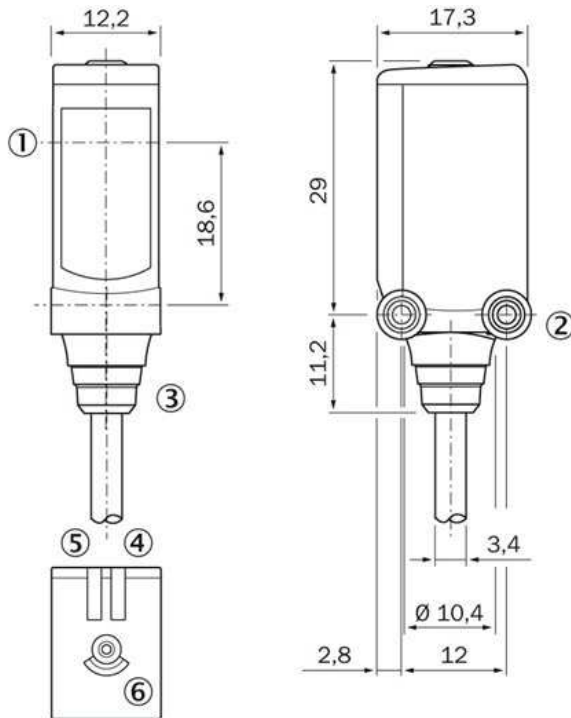

- |1| Center of optical axis
- |2| Threaded mounting hole M3
- |3| Connection
- |4| Status indicator LED green: supply voltage on
- |5| LED indicator orange: status of received light beam
- |6| Teach-in button

Connection diagram

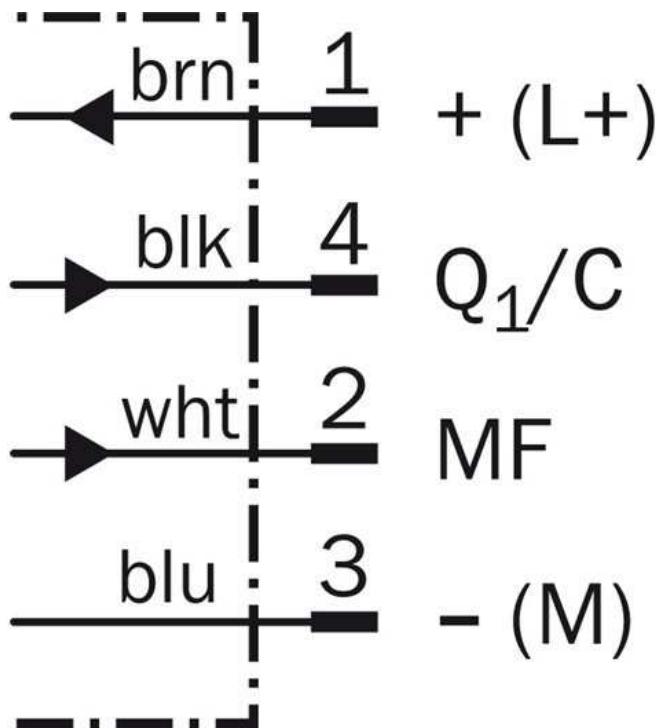

Characteristic curve

Operating reserve

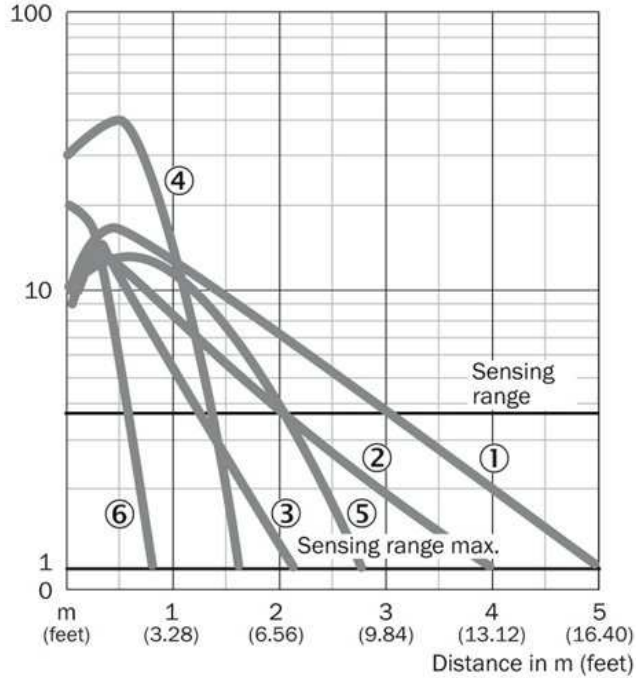

- |1| PL80A
- |2| PL40A
- |3| PL20A
- |4| PL10F
- |5| P250 CHEM
- |6| REF-IRF-56

Sensing range diagram

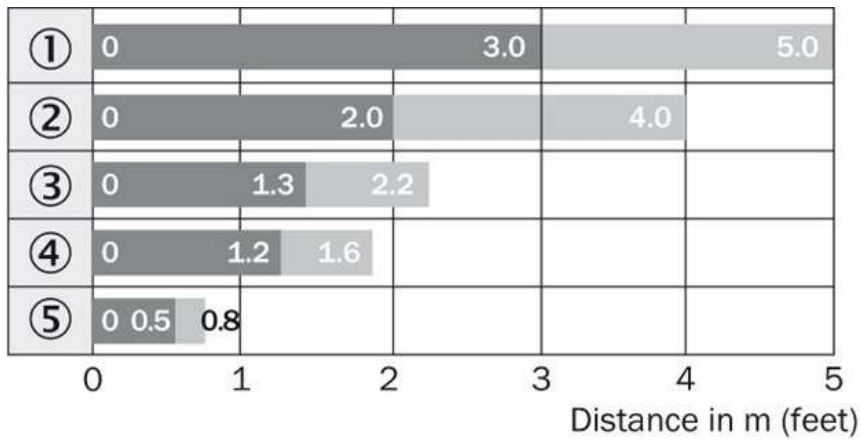

- |1| PL80A
- |2| PL40A
- |3| PL20A
- |4| PL10F
- |5| REF-IRF-56

■ Sensing range ■ Sensing range max.

Connection type



Light spot size

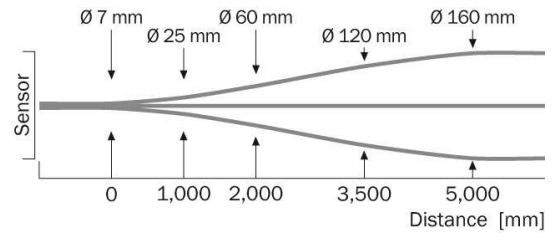

Australia

Phone +61 3 9457 0600
1800 33 48 02 – tollfree
E-Mail sales@sick.com.au

Belgium/Luxembourg

Phone +32 (0)2 466 55 66
E-Mail info@sick.be

Brasil

Phone +55 11 3215-4900
E-Mail marketing@sick.com.br

Canada

Phone +1 905 771 14 44
E-Mail information@sick.com

Česká republika

Phone +420 2 57 91 18 50
E-Mail sick@sick.cz

China

Phone +86 4000 121 000
E-Mail info.china@sick.net.cn
Phone +852-2153 6300
E-Mail ghk@sick.com.hk

Danmark

Phone +45 45 82 64 00
E-Mail sick@sick.dk

Deutschland

Phone +49 211 5301-301
E-Mail info@sick.de

España

Phone +34 93 480 31 00
E-Mail info@sick.es

France

Phone +33 1 64 62 35 00
E-Mail info@sick.fr

Great Britain

Phone +44 (0)1727 831121
E-Mail info@sick.co.uk

India

Phone +91-22-4033 8333
E-Mail info@sick-india.com

Israel

Phone +972-4-6881000
E-Mail info@sick-sensors.com

Italia

Phone +39 02 27 43 41
E-Mail info@sick.it

Japan

Phone +81 (0)3 5309 2112
E-Mail support@sick.jp

Magyarország

Phone +36 1 371 2680
E-Mail office@sick.hu

Nederland

Phone +31 (0)30 229 25 44
E-Mail info@sick.nl

Norge

Phone +47 67 81 50 00
E-Mail sick@sick.no

Österreich

Phone +43 (0)22 36 62 28 8-0
E-Mail office@sick.at

Polska

Phone +48 22 837 40 50
E-Mail info@sick.pl

România

Phone +40 356 171 120
E-Mail office@sick.ro

Russia

Phone +7-495-775-05-30
E-Mail info@sick.ru

Schweiz

Phone +41 41 619 29 39
E-Mail contact@sick.ch

Singapore

Phone +65 6744 3732
E-Mail sales.gsg@sick.com

Slovenija

Phone +386 (0)1-47 69 990
E-Mail office@sick.si

South Africa

Phone +27 11 472 3733
E-Mail info@sickautomation.co.za

South Korea

Phone +82 2 786 6321/4
E-Mail info@sickkorea.net

Suomi

Phone +358-9-25 15 800
E-Mail sick@sick.fi

Sverige

Phone +46 10 110 10 00
E-Mail info@sick.se

Taiwan

Phone +886 2 2375-6288
E-Mail sales@sick.com.tw

Türkiye

Phone +90 (216) 528 50 00
E-Mail info@sick.com.tr

United Arab Emirates

Phone +971 (0) 4 88 65 878
E-Mail info@sick.ae

USA/México

Phone +1(952) 941-6780
1 (800) 325-7425 – tollfree
E-Mail info@sickusa.com

More representatives and agencies
at www.sick.com