



Measuring automation light grids
2 x Analog + 1 x Q (IO-Link) , MLG-2 Prime

MLG05S-0895A10802



Model Name > [MLG05S-0895A10802](#)
Part No. > [1214002](#)



At a glance

- High-resolution light grid: Available with beam separation of 5 mm, 10 mm, 25 mm, and 50 mm
- Available with three push-pull switching outputs or two analog outputs
- Display configuration with selected, pre-programmed measuring functions
- Monitoring height up to 3.2 m
- Operating range up to 8.5 m
- Optical synchronization of sender and receiver
- Cloning function via IO-Link
- Temperature range from -30 °C to +55 °C

Your benefits

- Easy concept: Time and cost savings due to simple configuration and quick commissioning
- Modular concept offers the perfect solution every time from a single source
- Two optical synchronization beams increase operational safety
- Simple maintenance without the need for specialist staff thanks to the cloning function with IO-Link
- Direct configuration on the device display for quick commissioning
- IO-Link as an interface for configuration, measured data transfer and diagnostics
- Minimal specialist knowledge required by the user thanks to the intuitive arrangement of the most essential functions
- Extremely high operational safety due to rugged aluminum housing



Features

Technology:	Sender/receiver
Minimum detectable object (MDO) ¹⁾ ; ²⁾ :	9 mm
Beam separation:	5 mm
Number of beams:	180
Detection height:	895 mm
Version:	Prime
Software features:	Inverted: -, Q1: presence detection, Height measurement (first beam)/FBB, Height measurement (last beam)/LBB, Cross beam

¹⁾ MDO min. detectable object ²⁾ Dependent from beam separation without cross beam adjustment

Performance

Maximum range ¹⁾ :	11.2 m
Minimum range:	≥0 mm
Response time ²⁾ , ³⁾ :	20.3 ms
Working range:	8.5 m

¹⁾ No reserve for environmental issue and deterioration of the diode ²⁾ Without high speed ³⁾ With resistive load

Interfaces

Data interface:	2 x Analog + 1 x Q (IO-Link)
Electrical connection:	Connector M12, 5-pin
IO-Link:	✓

Mechanics/electronics

Wave length:	850 nm
Supply voltage V_s ¹⁾ :	DC 18 V ... 30 V
Power consumption sender ²⁾ :	64 mA
Power consumption receiver ³⁾ :	156 mA
Residual ripple:	< 5 Vpp
Output current $I_{max.}$:	100 mA
Output load capacitive:	100 nF
Output load inductive:	1 H
Initialization time:	< 1 s
Dimensions (W x H x D):	34 mm x 973.3 mm x 30.6 mm
Housing material:	Aluminum
Indication:	LED
Enclosure rating:	IP 65, IP 67
Circuit protection:	Output Q short-circuit protected, Interference suppression, VS connections reverse-polarity protected
Weight:	2.047 kg
Front screen:	PMMA
Option:	Nonexistent

¹⁾ Without load ²⁾ ³⁾ Without load with 24 V

Ambient data

Protection class:	III
EMC:	EN 60947-5-2
Ambient temperature:	Operation: -30 ... +55 °C, Storage: -40 ... +70 °C
Vibration resistance:	5 g, 10 Hz ... 55 Hz (EN 60 068-2-64)
Shock load:	15 g/DIN EN 60 068-2-27/16 ms
Ambient light immunity:	Direct: ≥12,500 lx, Indirect: ≥50,000 lx

Dimensional drawing

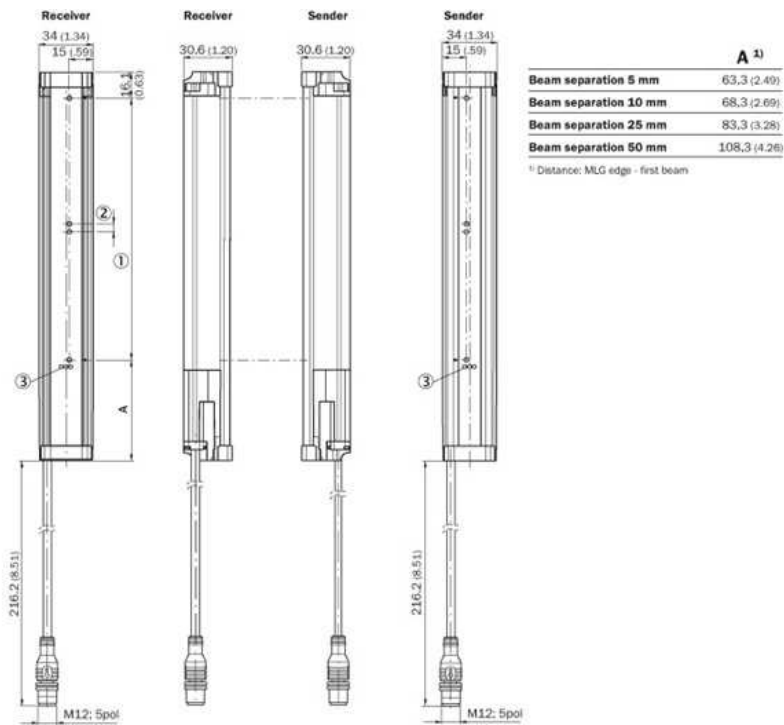

- [1] Detection height (see optical performance)
- [2] Beam separation RM
- [3] Status indicator: LEDs green, yellow, red

Adjustments

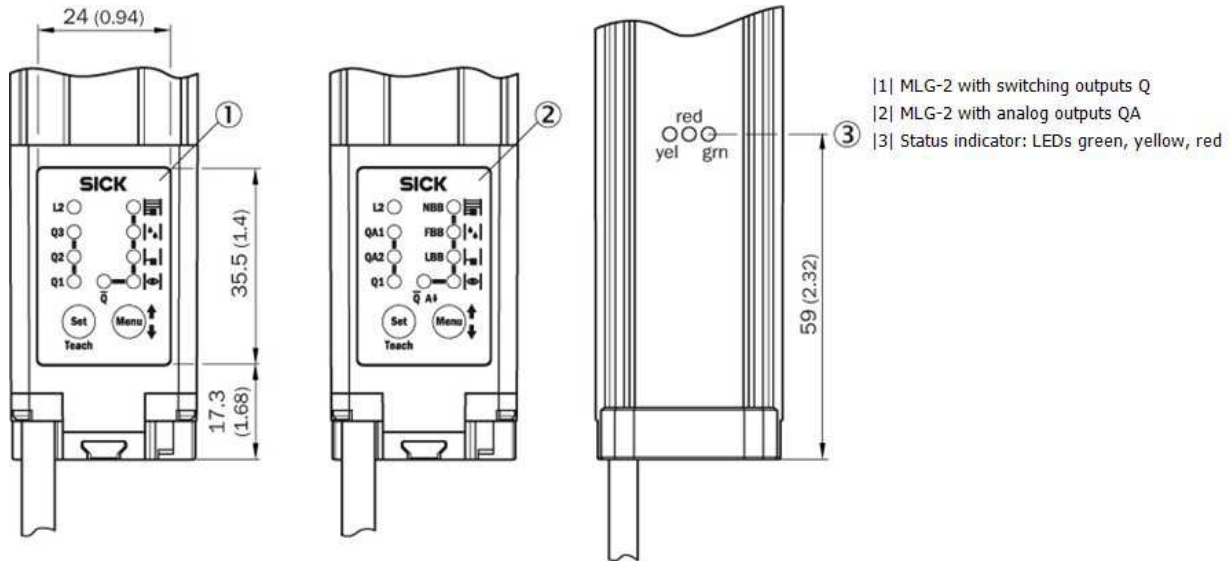

Anschlussart und -schema

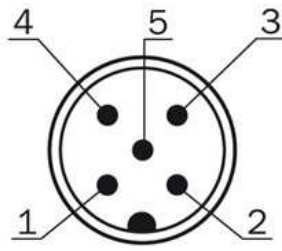
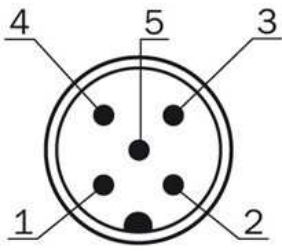

|1| not connected

Sender

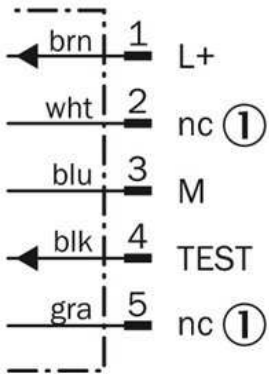

Receiver

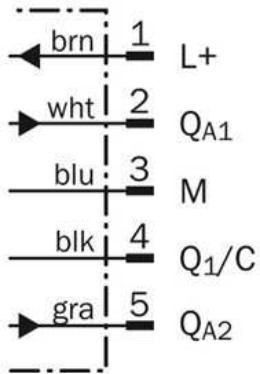

Australia

Phone +61 3 9457 0600
1800 33 48 02 – tollfree
E-Mail sales@sick.com.au

Belgium/Luxembourg

Phone +32 (0)2 466 55 66
E-Mail info@sick.be

Brasil

Phone +55 11 3215-4900
E-Mail marketing@sick.com.br

Canada

Phone +1 905 771 14 44
E-Mail information@sick.com

Česká republika

Phone +420 2 57 91 18 50
E-Mail sick@sick.cz

China

Phone +86 4000 121 000
E-Mail info.china@sick.net.cn
Phone +852-2153 6300
E-Mail ghk@sick.com.hk

Danmark

Phone +45 45 82 64 00
E-Mail sick@sick.dk

Deutschland

Phone +49 211 5301-301
E-Mail info@sick.de

España

Phone +34 93 480 31 00
E-Mail info@sick.es

France

Phone +33 1 64 62 35 00
E-Mail info@sick.fr

Great Britain

Phone +44 (0)1727 831121
E-Mail info@sick.co.uk

India

Phone +91-22-4033 8333
E-Mail info@sick-india.com

Israel

Phone +972-4-6881000
E-Mail info@sick-sensors.com

Italia

Phone +39 02 27 43 41
E-Mail info@sick.it

Japan

Phone +81 (0)3 5309 2112
E-Mail support@sick.jp

Magyarország

Phone +36 1 371 2680
E-Mail office@sick.hu

Nederland

Phone +31 (0)30 229 25 44
E-Mail info@sick.nl

Norge

Phone +47 67 81 50 00
E-Mail sick@sick.no

Österreich

Phone +43 (0)22 36 62 28 8-0
E-Mail office@sick.at

Polska

Phone +48 22 837 40 50
E-Mail info@sick.pl

România

Phone +40 356 171 120
E-Mail office@sick.ro

Russia

Phone +7-495-775-05-30
E-Mail info@sick.ru

Schweiz

Phone +41 41 619 29 39
E-Mail contact@sick.ch

Singapore

Phone +65 6744 3732
E-Mail sales.gsg@sick.com

Slovenija

Phone +386 (0)1-47 69 990
E-Mail office@sick.si

South Africa

Phone +27 11 472 3733
E-Mail info@sickautomation.co.za

South Korea

Phone +82 2 786 6321/4
E-Mail info@sickkorea.net

Suomi

Phone +358-9-25 15 800
E-Mail sick@sick.fi

Sverige

Phone +46 10 110 10 00
E-Mail info@sick.se

Taiwan

Phone +886 2 2375-6288
E-Mail sales@sick.com.tw

Türkiye

Phone +90 (216) 528 50 00
E-Mail info@sick.com.tr

United Arab Emirates

Phone +971 (0) 4 88 65 878
E-Mail info@sick.ae

USA/México

Phone +1(952) 941-6780
1 (800) 325-7425 – tollfree
E-Mail info@sickusa.com

More representatives and agencies
at www.sick.com