



Fiber-optic sensors
WLL260, Fiber-optic photoelectric sensor

WLL260-E240



Model Name > **WLL260-E240**
Part No. > **6020063**



Illustration may differ

At a glance

- Fiber-optic cable for proximity version
- Fiber-optic cable for through-beam version
- Mounting bracket is included
- Light/dark switching
- M12 connector or easily accessible terminal connection compartment
- Models for 10 - 30 V DC or 12 - 240 V DC/ 24 – 240 V AC voltage supply

Your benefits

- A diverse range of fiber-optic cables provide reliable detection of objects, even in the tightest of spaces
- Controls are protected under a cover, reducing tampering
- Easily accessible terminal connection compartment simplifies electrical connection
- Assembly compatibility - DC devices and DC/AC devices available in the same design



Features

Dimensions (W x H x D):	25 mm x 77.8 mm x 63 mm
Sensing range max.::	0 mm ... 110 mm, proximity system, 0 mm ... 65 mm, proximity system, 0 mm ... 800 mm, through-beam system ^{1) 2) 3) 4) 5)}
Sensing range:::	0 mm ... 50 mm, proximity system, 0 mm ... 700 mm, through-beam system, 0 mm ... 90 mm, proximity system ^{6) 7) 8)}
Light source:	LED ⁹⁾
Type of light:	Visible red light
Sensitivity adjustment:	Potentiometer, 270°
Indication:	LED
Light spot diameter (distance):	Depends on scanning range
Sensor/detection principle:	Fiber-optic photoelectric sensor
Housing design (light emission):	Rectangular

^{1) 3)} Object with 90 % reflectance (referred to standard white DIN 5033) ^{2) 5) 6) 8)} LIS/LIB ^{4) 7)} With special fibre-optic cable ⁹⁾ Average service life of 100,000 h at T

A = +25 °C

Mechanics/electronics

Enclosure rating:	IP 66
Supply voltage:	10 V DC ... 30 V DC ¹⁾
Residual ripple:	≤ 5 Vpp ²⁾

Power consumption:	$\leq 35 \text{ mA}$ ³⁾
Output type:	NPN, Light/dark-switching, selectable via light/dark selector, open collector
Output current I _{max.} :	100 mA
Response time:	$\leq 0.7 \text{ ms}$ ⁴⁾
Switching frequency:	700 Hz ⁵⁾
Electrical connection:	Cable gland
Protection class:	II ⁶⁾
Circuit protection:::	A, B, C, D ^{7) 8) 9) 10)}
Housing material:	ABS
Ambient temperature operation:	-25 °C ... 55 °C
Ambient storage temperature:	-40 °C ... 70 °C
Weight:	120 g
Items supplied:	Mounting bracket BEF-W260
Test input sender off:	TE to 0 V
UL File-No.:	UL No. NRNT2.E128350 & cUL No. NRNT8.E128350

1) Limit values, operation in short-circuit protected network max. 8 A ²⁾ May not exceed or fall short of V_S tolerances ³⁾ Without load ⁴⁾ Signal transit time with resistive load ⁵⁾ With light/dark ratio 1:1 ⁶⁾ Reference voltage 50 V DC ⁷⁾ A = V_S connections reverse-polarity protected ⁸⁾ B = inputs and output reverse-polarity protected ⁹⁾ C = interference suppression ¹⁰⁾ D = outputs overcurrent and short-circuit protected

Dimensional drawing

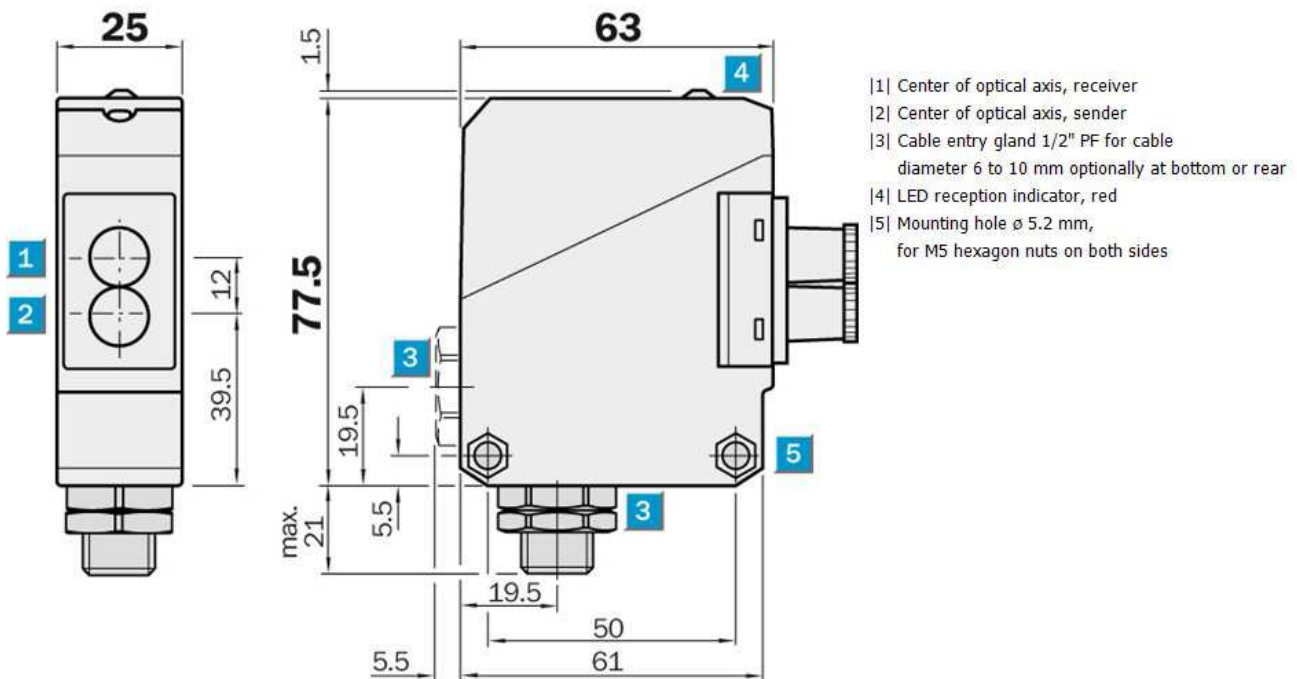

Adjustments possible

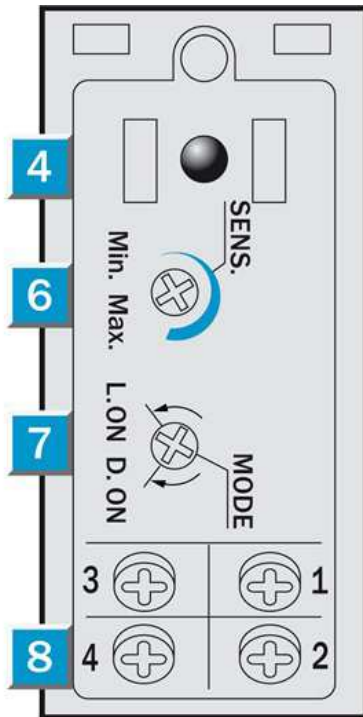

- |4| LED signal strength indicator, red
- |6| Sensitivity adjustment
- |7| Light/ dark rotary switch L = light switching, D = dark switching

Connection diagram

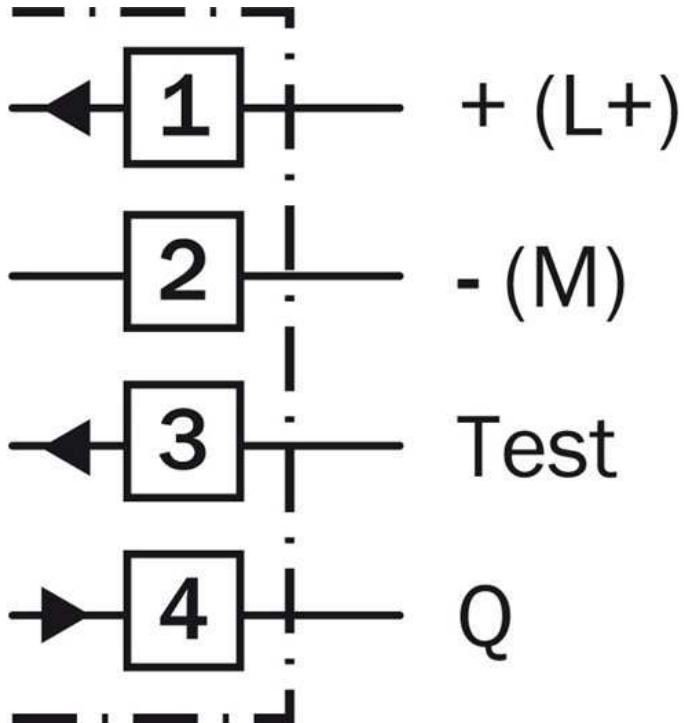

Connection type

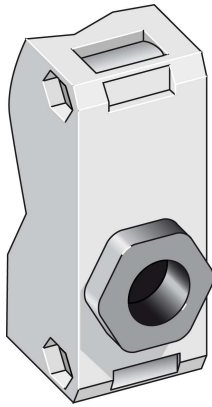

Australia

Phone +61 3 9457 0600
1800 33 48 02 – tollfree
E-Mail sales@sick.com.au

Belgium/Luxembourg

Phone +32 (0)2 466 55 66
E-Mail info@sick.be

Brasil

Phone +55 11 3215-4900
E-Mail marketing@sick.com.br

Canada

Phone +1 905 771 14 44
E-Mail information@sick.com

Česká republika

Phone +420 2 57 91 18 50
E-Mail sick@sick.cz

China

Phone +86 4000 121 000
E-Mail info.china@sick.net.cn
Phone +852-2153 6300
E-Mail ghk@sick.com.hk

Danmark

Phone +45 45 82 64 00
E-Mail sick@sick.dk

Deutschland

Phone +49 211 5301-301
E-Mail info@sick.de

España

Phone +34 93 480 31 00
E-Mail info@sick.es

France

Phone +33 1 64 62 35 00
E-Mail info@sick.fr

Great Britain

Phone +44 (0)1727 831121
E-Mail info@sick.co.uk

India

Phone +91-22-4033 8333
E-Mail info@sick-india.com

Israel

Phone +972-4-6881000
E-Mail info@sick-sensors.com

Italia

Phone +39 02 27 43 41
E-Mail info@sick.it

Japan

Phone +81 (0)3 5309 2112
E-Mail support@sick.jp

Magyarország

Phone +36 1 371 2680
E-Mail office@sick.hu

Nederland

Phone +31 (0)30 229 25 44
E-Mail info@sick.nl

Norge

Phone +47 67 81 50 00
E-Mail sick@sick.no

Österreich

Phone +43 (0)22 36 62 28 8-0
E-Mail office@sick.at

Polska

Phone +48 22 837 40 50
E-Mail info@sick.pl

România

Phone +40 356 171 120
E-Mail office@sick.ro

Russia

Phone +7-495-775-05-30
E-Mail info@sick.ru

Schweiz

Phone +41 41 619 29 39
E-Mail contact@sick.ch

Singapore

Phone +65 6744 3732
E-Mail sales.gsg@sick.com

Slovenija

Phone +386 (0)1-47 69 990
E-Mail office@sick.si

South Africa

Phone +27 11 472 3733
E-Mail info@sickautomation.co.za

South Korea

Phone +82 2 786 6321/4
E-Mail info@sickkorea.net

Suomi

Phone +358-9-25 15 800
E-Mail sick@sick.fi

Sverige

Phone +46 10 110 10 00
E-Mail info@sick.se

Taiwan

Phone +886 2 2375-6288
E-Mail sales@sick.com.tw

Türkiye

Phone +90 (216) 528 50 00
E-Mail info@sick.com.tr

United Arab Emirates

Phone +971 (0) 4 88 65 878
E-Mail info@sick.ae

USA/México

Phone +1(952) 941-6780
1 (800) 325-7425 – tollfree
E-Mail info@sickusa.com

More representatives and agencies
at www.sick.com