



Photoelectric sensors
VL12-2, Photoelectric retro-reflective sensor

VL12-2P430



Model Name > VL12-2P430
Part No. > 6026220



Illustration may differ

At a glance

- Sensing distance up to 2.8 m (with PL80A reflector)
- Switching reliability with highly-reflective objects
- Adjustable light or dark switching at control input
- Operating reserve display
- M12 device connector, 4-pin or 2 m connection line
- M12 metal housing with an IP 67 enclosure rating

Your benefits

- Economical solution for reliably detecting reflective objects up to 2.8 m (with PL80A reflector)
- Standard M12 miniature housing saves installation space on the machine
- Simple design and time-saving installation due to a standard M12 housing
- Polarizing filter prevents false readings on reflective surfaces, reducing downtime
- Fast and simple alignment to the reflector due to visible red light
- Fast response times ensure reliable detection of objects at high speeds, increasing machine throughput
- Tough metal housing provides a long service life, reducing maintenance time and costs



Features

Sensor/detection principle:	Photoelectric retro-reflective sensor
Housing design (light emission):	Cylindrical, straight
Housing length:	66 mm
Thread diameter (housing):	M12 x 1
Sensing range max.:	0.03 m ... 2.8 m ¹⁾
Sensing range:	0.03 m ... 2.3 m ²⁾
Type of light:	Visible red light
Light source:	LED ³⁾
Wave length:	660 nm
Light spot diameter (distance):	Ø 80 mm (2 m)
Angle of dispersion:	Ca. 2.3 °

^{1) 2)} PL80A ³⁾ Average service life of 100,000 h at T_A = +25 °C

Mechanics/electronics

Supply voltage:	10 V DC ... 30 ¹⁾
-----------------	------------------------------

Residual ripple:	$\leq 10\%$ ²⁾
Power consumption:	20 ³⁾
Output type:	PNP, Light/dark-switching, Selectable via L/D control wire
Output current I _{max} .:	100 ⁴⁾
Response time:	≤ 1.25 ms ⁵⁾
Switching frequency:	400 ⁶⁾
Electrical connection:	Connector M12, 4-pin
Circuit protection:::	A, B, C, D ^{7) 8) 9) 10)}
Protection class:	III
Weight:	18 g
Polarisation filter:	✓
Housing material:	Nickel-plated brass/PA
Optics material:	PMMA
Enclosure rating:	IP 67
Ambient temperature operation:	-25 ... 70 °C
Ambient storage temperature:	-25 ... 70 °C

1) Limit values 2) May not exceed or fall short of V_S tolerances 3) 4) Without load 5) Signal transit time with resistive load 6) With light/dark ratio 1:1 7) $A = V_S$
connections reverse-polarity protected 8) B = inputs and output reverse-polarity protected 9) C = interference suppression 10) D = outputs overcurrent and short-circuit protected

Dimensional drawing

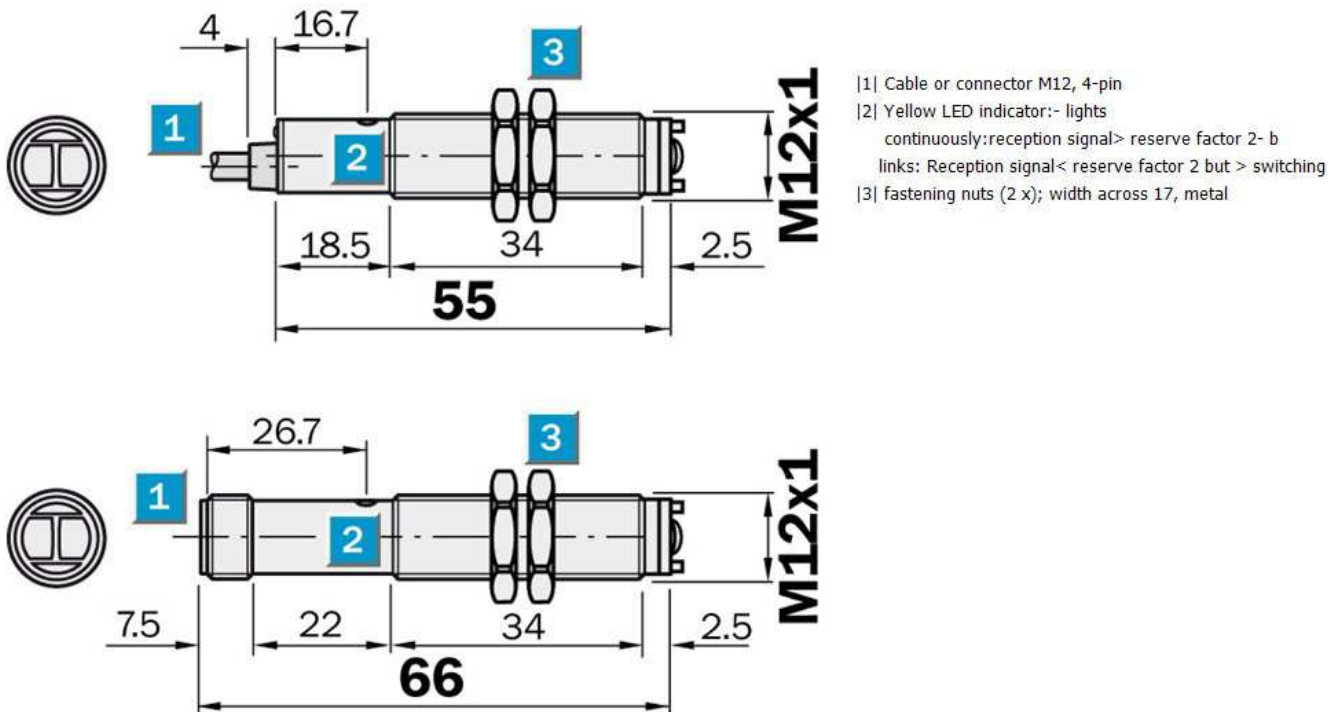

Adjustments possible

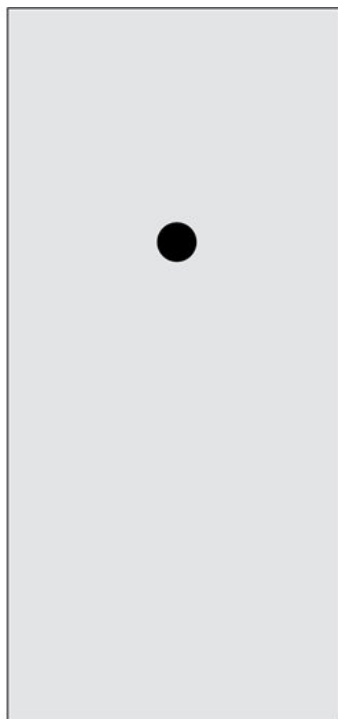

Connection diagram

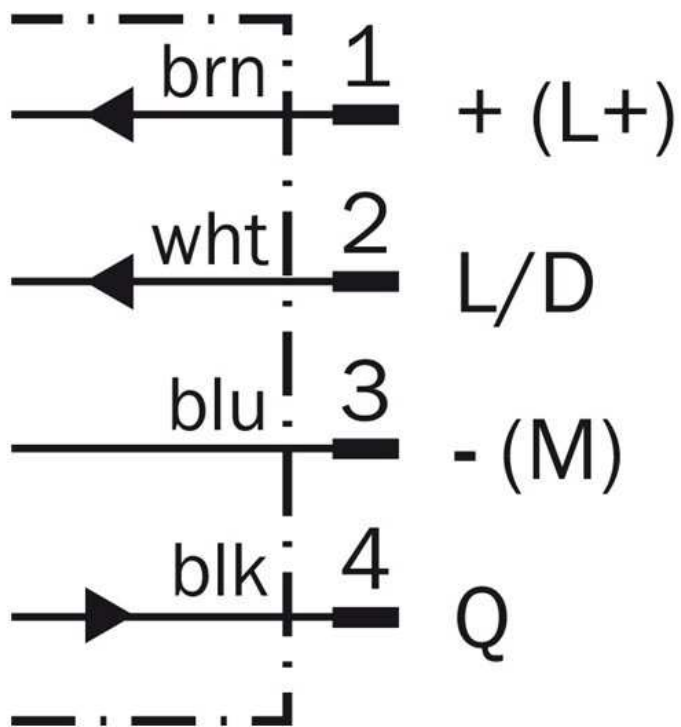

Characteristic curve

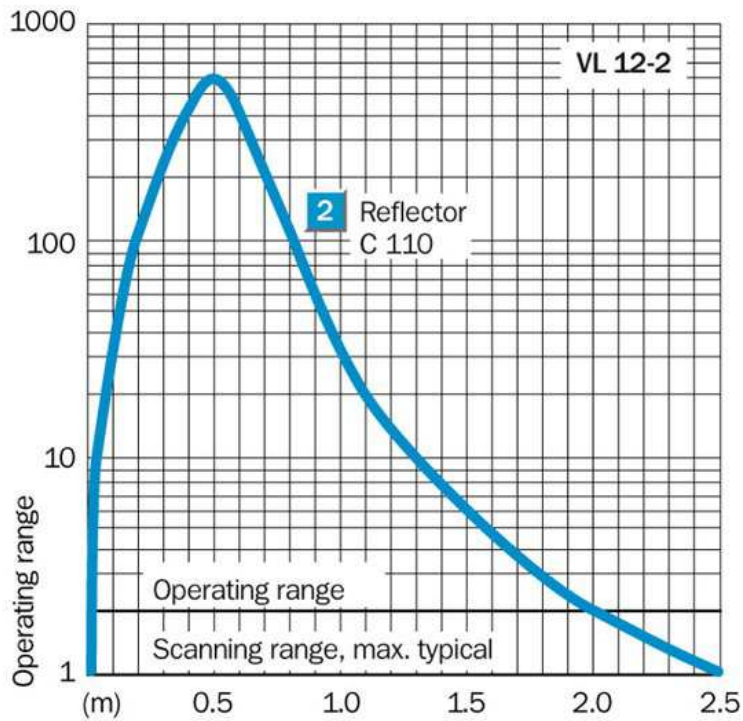

Sensing range diagram

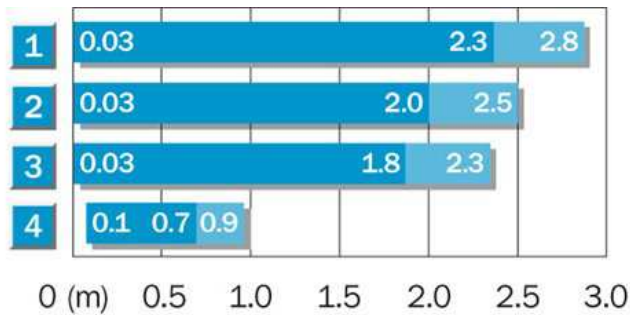

Operating range
 Scanning range, max. typical

	Reflector type	Operating range
1	PL 80 A	0.03 ... 2.3 m
2	C 110	0.03 ... 2.0 m
3	PL 50 A/PL 40 A/ P 250	0.03 ... 1.8 m
4	Reflective tape Diamond Grade	0.1 ... 0.7 m

Connection type



Australia

Phone +61 3 9457 0600
1800 33 48 02 – tollfree
E-Mail sales@sick.com.au

Belgium/Luxembourg

Phone +32 (0)2 466 55 66
E-Mail info@sick.be

Brasil

Phone +55 11 3215-4900
E-Mail marketing@sick.com.br

Canada

Phone +1 905 771 14 44
E-Mail information@sick.com

Česká republika

Phone +420 2 57 91 18 50
E-Mail sick@sick.cz

China

Phone +86 4000 121 000
E-Mail info.china@sick.net.cn
Phone +852-2153 6300
E-Mail ghk@sick.com.hk

Danmark

Phone +45 45 82 64 00
E-Mail sick@sick.dk

Deutschland

Phone +49 211 5301-301
E-Mail info@sick.de

España

Phone +34 93 480 31 00
E-Mail info@sick.es

France

Phone +33 1 64 62 35 00
E-Mail info@sick.fr

Great Britain

Phone +44 (0)1727 831121
E-Mail info@sick.co.uk

India

Phone +91-22-4033 8333
E-Mail info@sick-india.com

Israel

Phone +972-4-6881000
E-Mail info@sick-sensors.com

Italia

Phone +39 02 27 43 41
E-Mail info@sick.it

Japan

Phone +81 (0)3 5309 2112
E-Mail support@sick.jp

Magyarország

Phone +36 1 371 2680
E-Mail office@sick.hu

Nederland

Phone +31 (0)30 229 25 44
E-Mail info@sick.nl

Norge

Phone +47 67 81 50 00
E-Mail sick@sick.no

Österreich

Phone +43 (0)22 36 62 28 8-0
E-Mail office@sick.at

Polska

Phone +48 22 837 40 50
E-Mail info@sick.pl

România

Phone +40 356 171 120
E-Mail office@sick.ro

Russia

Phone +7-495-775-05-30
E-Mail info@sick.ru

Schweiz

Phone +41 41 619 29 39
E-Mail contact@sick.ch

Singapore

Phone +65 6744 3732
E-Mail sales.gsg@sick.com

Slovenija

Phone +386 (0)1-47 69 990
E-Mail office@sick.si

South Africa

Phone +27 11 472 3733
E-Mail info@sickautomation.co.za

South Korea

Phone +82 2 786 6321/4
E-Mail info@sickkorea.net

Suomi

Phone +358-9-25 15 800
E-Mail sick@sick.fi

Sverige

Phone +46 10 110 10 00
E-Mail info@sick.se

Taiwan

Phone +886 2 2375-6288
E-Mail sales@sick.com.tw

Türkiye

Phone +90 (216) 528 50 00
E-Mail info@sick.com.tr

United Arab Emirates

Phone +971 (0) 4 88 65 878
E-Mail info@sick.ae

USA/México

Phone +1(952) 941-6780
1 (800) 325-7425 – tollfree
E-Mail info@sickusa.com

More representatives and agencies
at www.sick.com