



Fiber-optic sensors
WLL190T-2, Fiber-optic photoelectric sensor

WLL190T-2L494



Model Name > [WLL190T-2L494](#)
Part No. > [6033299](#)



Illustration may differ

At a glance

- Sensing range up to 4 m, sensing distance up to 480 mm
- Two separately adjustable channels
- Alarm output
- Optional analog output
- Integrated counter
- Bus-compatible with anti-interference
- 2 x 4-digit display
- Red and green LED emitter

Your benefits

- Two channels can be configured independently of one another, simplifying installation
- Simple commissioning and product changeover via external teach-in
- Bus communication saves space and money, reduces wiring and eliminates interference caused by fiber-optic heads mounted close to one another
- Easy monitoring of process parameters
- Time delays can be adjusted individually to suit the application
- APC for (Automatic Power Correction) long-term, stable detection
- Alarm output for reliable detection in adverse conditions, ensuring high process reliability



Features

Device type:	Base unit ¹⁾
Dimensions (W x H x D):	10.5 mm x 34.8 mm x 68.9 mm
Sensing range max.:::	0 m ... 4 m, through-beam system ^{2) 3)}
Sensing range:::	0 m ... 900 mm, through-beam system, 0 mm ... 160 mm, proximity system ^{4) 5) 6)}
Light source:	LED ⁷⁾
Type of light:	Green light
Wave length:	525 nm
Sensitivity adjustment:	Teach-in button cable +/- increment button, manual
Adjustment of operating distance:	Cable, +/- increment button, manual, Teach-in button
Teach-in:	Menu-controlled

Time type:	Without time delay time delay off switch on delay one shot
Delay time:	Programmable: 0 ... 9,999 ms
Indication:	Display
Sensor/detection principle:	Fiber-optic photoelectric sensor
Angle of dispersion:	Ca. 65 °
Housing design (light emission):	Rectangular
Display:	LED status display/2x 4-character digital dual displays, Set value (green indicator) and actual value (red indicator) are displayed simultaneously, display of parameters

1) Up to 15 expansion units can be connected 2) Sensing range at response time 2 ms. Reduction at shorter response time (see LL3/ WLL190T-2 table) 3) LL3-TB02 and tip adapter LL3-TA01 4) Objects to be sensed with 90% reflectivity (based on DIN 5033 white standard). Sensing range with 2 ms response time. Reduction with shorter response time (see tables LL3/WLL190T-2) 5) LL3DM01 6) LL3-TB01 7) Average service life of 100,000 h at T_A = +25 °C

Mechanics/electronics

Enclosure rating:	IP 50 ¹⁾
Supply voltage:	10 V DC ... 24 V DC ²⁾
Residual ripple:	≤ 10 % ³⁾
Power consumption:	≤ 50 mA
Output type::	NPN, Light/dark-switching, manually selectable, open collector ^{4) 5)}
Output current I _{max} ::	≤ 100 mA
Response time:	≤ 2 ms ≤ 60 μs ≤ 250 μs
Switching frequency:	8,333 Hz 2,000 Hz 250 Hz
Electrical connection:	Connector M8, 4-pin
Protection class:	III
Circuit protection:::	A, B, C, D ^{6) 7) 8) 9)}
Special device:	0
Housing material:	ABS/PC
Ambient temperature operation:	-25 °C ... 55 °C ¹⁰⁾
Ambient storage temperature:	-40 °C ... 70 °C
Weight:	25 g

Q1, Q2; Selectable Q2, external teach or counter reset; See LL3 fiber-optic data;

1) With correctly attached fibre-optic cable LL3 and closed protection hood 2) +/- 10% 3) May not exceed or fall short of V_S tolerances 4) Q1, Q2 5) Selectable Q2, external teach or counter reset 6) A = V_S connections reverse-polarity protected 7) B = inputs and output reverse-polarity protected 8) C = interference suppression 9) D = outputs overcurrent and short-circuit protected 10) Operating temperature fluctuates according to number of devices connected: 4-8 devices: -25 °C ... +50 °C (output current 50 mA)/9-16 devices: -25 °C ... +45 °C (output current 20 mA)

Dimensional drawing

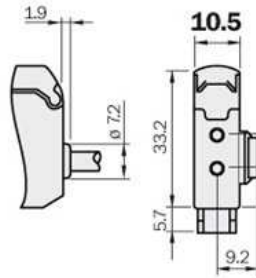
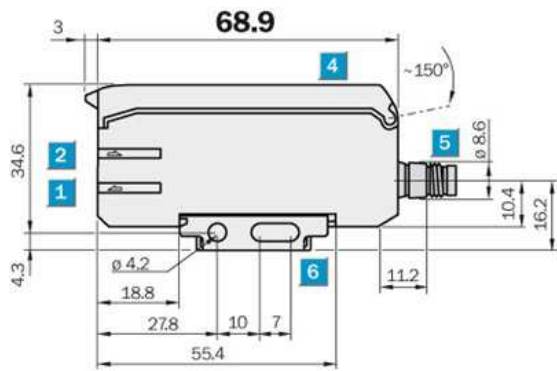

- |1| Sender LED, installation of LL3 fibre-optic cable (sender fibre)
- |2| Receiver, installation of LL3 fibre optic cable (receiver fibre)
- |3| Locking the fiber-optic cables
- |4| Protective hood, can be raised at both ends
- |5| Connector M8 or 1-wire cable or 3-wire cable replaceable (cables not included with delivery)
- |6| Mounting bracket, included

Adjustments possible

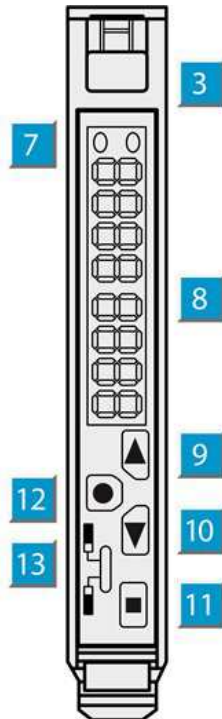

- |3| Locking the fiber-optic cables
- |7| LED indicator yellow; lights
continuously: output aktivno light;
output inactiveblinks slowly: shot circuit detected
- |8| Numeric display 3-digit and 4-digit
- |9| Step-button> (manual switching
threshold: higher; or next function parameter)
- |10| Step-button< (manual switching
threshold: lower; or previous function parameter)
- |11| Teach-in button
- |12| Mode/Enter-button

Connection diagram

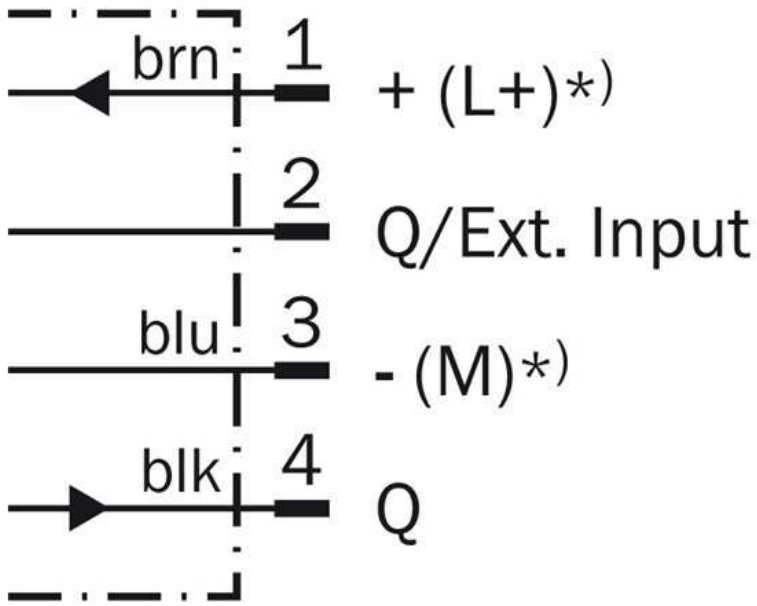

*) Only base unit

Connection type

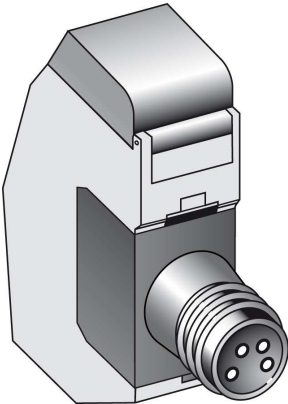

Australia

Phone +61 3 9457 0600
1800 33 48 02 – tollfree
E-Mail sales@sick.com.au

Belgium/Luxembourg

Phone +32 (0)2 466 55 66
E-Mail info@sick.be

Brasil

Phone +55 11 3215-4900
E-Mail marketing@sick.com.br

Canada

Phone +1 905 771 14 44
E-Mail information@sick.com

Česká republika

Phone +420 2 57 91 18 50
E-Mail sick@sick.cz

China

Phone +86 4000 121 000
E-Mail info.china@sick.net.cn
Phone +852-2153 6300
E-Mail ghk@sick.com.hk

Danmark

Phone +45 45 82 64 00
E-Mail sick@sick.dk

Deutschland

Phone +49 211 5301-301
E-Mail info@sick.de

España

Phone +34 93 480 31 00
E-Mail info@sick.es

France

Phone +33 1 64 62 35 00
E-Mail info@sick.fr

Great Britain

Phone +44 (0)1727 831121
E-Mail info@sick.co.uk

India

Phone +91-22-4033 8333
E-Mail info@sick-india.com

Israel

Phone +972-4-6881000
E-Mail info@sick-sensors.com

Italia

Phone +39 02 27 43 41
E-Mail info@sick.it

Japan

Phone +81 (0)3 5309 2112
E-Mail support@sick.jp

Magyarország

Phone +36 1 371 2680
E-Mail office@sick.hu

Nederland

Phone +31 (0)30 229 25 44
E-Mail info@sick.nl

Norge

Phone +47 67 81 50 00
E-Mail sick@sick.no

Österreich

Phone +43 (0)22 36 62 28 8-0
E-Mail office@sick.at

Polska

Phone +48 22 837 40 50
E-Mail info@sick.pl

România

Phone +40 356 171 120
E-Mail office@sick.ro

Russia

Phone +7-495-775-05-30
E-Mail info@sick.ru

Schweiz

Phone +41 41 619 29 39
E-Mail contact@sick.ch

Singapore

Phone +65 6744 3732
E-Mail sales.gsg@sick.com

Slovenija

Phone +386 (0)1-47 69 990
E-Mail office@sick.si

South Africa

Phone +27 11 472 3733
E-Mail info@sickautomation.co.za

South Korea

Phone +82 2 786 6321/4
E-Mail info@sickkorea.net

Suomi

Phone +358-9-25 15 800
E-Mail sick@sick.fi

Sverige

Phone +46 10 110 10 00
E-Mail info@sick.se

Taiwan

Phone +886 2 2375-6288
E-Mail sales@sick.com.tw

Türkiye

Phone +90 (216) 528 50 00
E-Mail info@sick.com.tr

United Arab Emirates

Phone +971 (0) 4 88 65 878
E-Mail info@sick.ae

USA/México

Phone +1(952) 941-6780
1 (800) 325-7425 – tollfree
E-Mail info@sickusa.com

More representatives and agencies
at www.sick.com