



Fiber-optic sensors  
WLL170-2, Fiber-optic photoelectric sensor

WLL170T-2N162



**Model Name** > [WLL170T-2N162](#)  
**Part No.** > [6033960](#)



*Illustration may differ*

**At a glance**

- Rapid response time (50 µs)
- Switching threshold adjustment via potentiometer, or teach-in via button or cable
- Four different teach-in modes
- Simple installation
- Red or green LED emitter

**Your benefits**

- Reliable, rapid process detection
- Low installation costs due to short commissioning time
- Flexible teach-in modes allow the sensor to be customized according to the specific application
- Emitted light ideal for color or contrast detection
- Easy programming via simple potentiometer and switch adjustment



**Features**

Dimensions (W x H x D):	10.5 mm x 35.5 mm x 83.7 mm
Sensing range max.:	0 mm ... 1,500 mm, through-beam system <sup>1)</sup>
Sensing range:::	2) 3) 4) 300 mm, through-beam system, 0 mm ... 60 mm, proximity system
Light source:	LED <sup>5)</sup>
Type of light:	Visible red light
Wave length:	660 nm
Sensitivity adjustment:	Teach-in button cable
Adjustment of operating distance:	Cable, Teach-in button
Teach-in:	Menu-controlled
Time type:	Off-delayed
Delay time:	Selectable by sliding switch: ≥40 ms
Indication:	LED
Sensor/detection principle:	Fiber-optic photoelectric sensor
Angle of dispersion:	Ca. 65 °
Housing design (light emission):	Rectangular

<sup>1)</sup> LL3-TB02 and tip adapter LL3-TA01 <sup>2)</sup> Objects to be sensed with 90% reflectivity (based on DIN 5033 white standard). Sensing range depends on fiber-optic cable  
<sup>3)</sup> LL3DM01 <sup>4)</sup> LL3-TB01 <sup>5)</sup> Average service life of 100,000 h at T<sub>A</sub> = +25 °C

## Mechanics/electronics

---

Enclosure rating:	IP 66 <sup>1)</sup>
Supply voltage:	10 V DC ... 30 V DC <sup>2)</sup>
Residual ripple:	10 % <sup>3)</sup>
Power consumption:	≤ 30 mA <sup>4)</sup>
Output type:	NPN, Light/dark-switching, selectable via light/dark selector, open collector
Output current I <sub>max</sub> .:	≤ 100 mA
Response time:	≤ 50 μs <sup>5)</sup>
Switching frequency:	10,000 Hz <sup>6)</sup>
Electrical connection:	Cable, 4-wire, 2 m <sup>7)</sup>
Cable material:	PVC
Conductor cross-section:	0.2 mm <sup>2</sup>
Protection class:	III
Circuit protection:::	A, B, C, D <sup>8) 9) 10) 11)</sup>
Special device:	0
Housing material:	ABS
Ambient temperature operation:	-25 °C ... 55 °C
Ambient storage temperature:	-40 °C ... 70 °C
UL File-No.:	UL No. NRKH.E300503 & cUL No. NRKH7.E300503

See LL3 fiber-optic data;

<sup>1)</sup> With correctly attached fibre-optic cable LL3 and closed protection hood <sup>2)</sup> Limit values <sup>3)</sup> May not exceed or fall short of  $V_S$  tolerances <sup>4)</sup> Without load <sup>5)</sup> Signal transit time with resistive load <sup>6)</sup> With light/dark ratio 1:1 <sup>7)</sup> Do not bend below 0 °C <sup>8)</sup> A =  $V_S$  connections reverse-polarity protected <sup>9)</sup> B = inputs and output reverse-polarity protected <sup>10)</sup> C = interference suppression <sup>11)</sup> D = outputs overcurrent and short-circuit protected

## Dimensional drawing

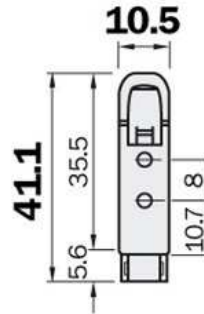
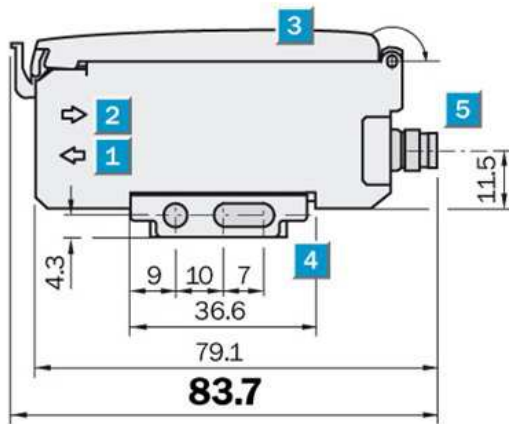
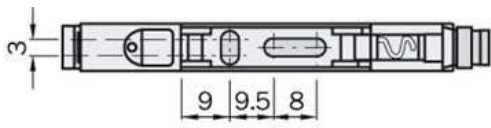

- |1| Sender LED, installation of LL3 fibre-optic cable (sender fibre)
- |2| Receiver, installation of LL3 fibre optic cable (receiver fibre)
- |3| Protective hood, can be raised at both ends
- |4| Mounting bracket, included
- |5| Connection

## Adjustments possible

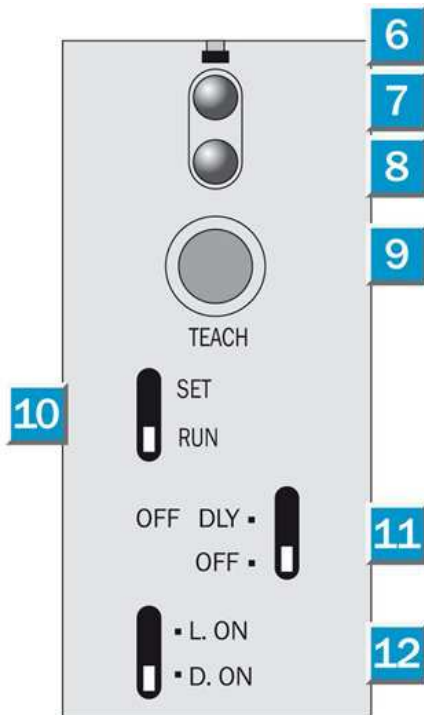

- |6| Indication of correct fibre-optic cable mounting
- |7| LED indicator orange: switching output active
- |8| LED signal strength indicator  
green, lights up, when light received < 0.9 or > 1.1 (switching threshold = 1)
- |9| Teach-in button
- |10| Operating mode selector  
switch: "SET" (Teach-in mode) / "RUN" (sensor mode)
- |11| L.ON/ d.ON selection  
switch: "OFF DLY" (on) / "OFF", 40 ms fixed
- |12| Selector switch: "L.ON" (light-switching) / "D.ON" (dark-switching)

Connection diagram

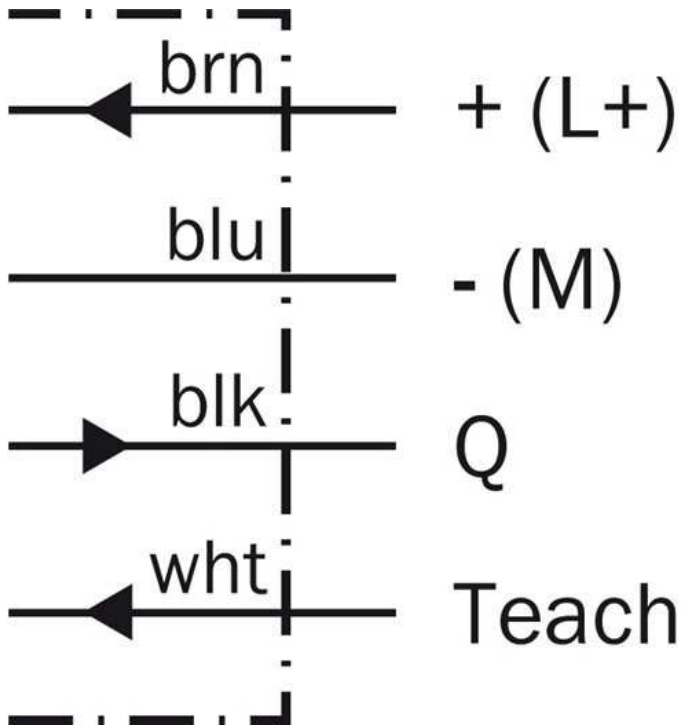

Connection type

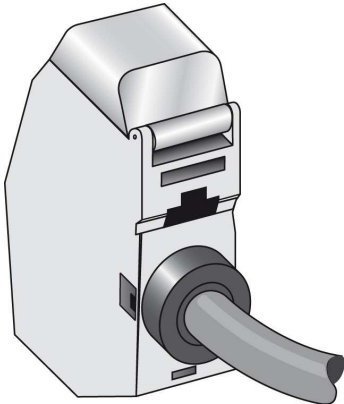

**Australia**

Phone +61 3 9457 0600  
1800 33 48 02 – tollfree  
E-Mail sales@sick.com.au

**Belgium/Luxembourg**

Phone +32 (0)2 466 55 66  
E-Mail info@sick.be

**Brasil**

Phone +55 11 3215-4900  
E-Mail marketing@sick.com.br

**Canada**

Phone +1 905 771 14 44  
E-Mail information@sick.com

**Česká republika**

Phone +420 2 57 91 18 50  
E-Mail sick@sick.cz

**China**

Phone +86 4000 121 000  
E-Mail info.china@sick.net.cn  
Phone +852-2153 6300  
E-Mail ghk@sick.com.hk

**Danmark**

Phone +45 45 82 64 00  
E-Mail sick@sick.dk

**Deutschland**

Phone +49 211 5301-301  
E-Mail info@sick.de

**España**

Phone +34 93 480 31 00  
E-Mail info@sick.es

**France**

Phone +33 1 64 62 35 00  
E-Mail info@sick.fr

**Great Britain**

Phone +44 (0)1727 831121  
E-Mail info@sick.co.uk

**India**

Phone +91-22-4033 8333  
E-Mail info@sick-india.com

**Israel**

Phone +972-4-6881000  
E-Mail info@sick-sensors.com

**Italia**

Phone +39 02 27 43 41  
E-Mail info@sick.it

**Japan**

Phone +81 (0)3 5309 2112  
E-Mail support@sick.jp

**Magyarország**

Phone +36 1 371 2680  
E-Mail office@sick.hu

**Nederland**

Phone +31 (0)30 229 25 44  
E-Mail info@sick.nl

**Norge**

Phone +47 67 81 50 00  
E-Mail sick@sick.no

**Österreich**

Phone +43 (0)22 36 62 28 8-0  
E-Mail office@sick.at

**Polska**

Phone +48 22 837 40 50  
E-Mail info@sick.pl

**România**

Phone +40 356 171 120  
E-Mail office@sick.ro

**Russia**

Phone +7-495-775-05-30  
E-Mail info@sick.ru

**Schweiz**

Phone +41 41 619 29 39  
E-Mail contact@sick.ch

**Singapore**

Phone +65 6744 3732  
E-Mail sales.gsg@sick.com

**Slovenija**

Phone +386 (0)1-47 69 990  
E-Mail office@sick.si

**South Africa**

Phone +27 11 472 3733  
E-Mail info@sickautomation.co.za

**South Korea**

Phone +82 2 786 6321/4  
E-Mail info@sickkorea.net

**Suomi**

Phone +358-9-25 15 800  
E-Mail sick@sick.fi

**Sverige**

Phone +46 10 110 10 00  
E-Mail info@sick.se

**Taiwan**

Phone +886 2 2375-6288  
E-Mail sales@sick.com.tw

**Türkiye**

Phone +90 (216) 528 50 00  
E-Mail info@sick.com.tr

**United Arab Emirates**

Phone +971 (0) 4 88 65 878  
E-Mail info@sick.ae

**USA/México**

Phone +1(952) 941-6780  
1 (800) 325-7425 – tollfree  
E-Mail info@sickusa.com

More representatives and agencies  
at [www.sick.com](http://www.sick.com)