



Photoelectric sensors  
W8, Photoelectric retro-reflective sensor,  
autocollimation

WL8-P1131S04



**Model Name** > [WL8-P1131S04](#)  
**Part No.** > [6048889](#)



*Illustration may differ*

**Your benefits**

- Reliable object detection even at the shortest distances (no blind spot) or through narrow gaps
- Highly visible light spot makes alignment quick and easy
- Autocollimation combined with 2 kHz switching frequency ensures reliable detection of small objects, even at fast detection speeds
- M3 threaded holes provide quick installation
- Polarization filters prevent false readings on glossy objects
- All necessary accessories (bracket and reflector) are included with delivery, reducing installation and procurement costs



**Features**

Sensor/detection principle:	Photoelectric retro-reflective sensor, autocollimation
Dimensions (W x H x D):	11 mm x 31 mm x 20 mm
Housing design (light emission):	Rectangular, Slim
Sensing range max.:	0 m ... 4 m <sup>1)</sup>
Sensing range:	0 m ... 3 m <sup>2)</sup>
Type of light:	Visible red light
Light source:	LED <sup>3)</sup>
Wave length:	650 nm
Alarm output:	-
Focus adjustable:	-
Special features:	Mounting hole Ø 3.2mm without thread, distance between mounting holes 23mm
Adjustment:	Potentiometer, 270 °
Light spot size (distance):	Ø 30 mm (1 m)

<sup>1) 2)</sup> PL80A <sup>3)</sup> Average service life of 100,000 h at T<sub>A</sub> = +25 °C

**Mechanics/electronics**

Supply voltage:	10 V DC ... 30 V DC <sup>1)</sup>
Residual ripple:	± 10 % <sup>2)</sup>
Power consumption:	≤ 30 mA <sup>3)</sup>
Output type:	PNP
Switching mode:	Light/dark switching
Output characteristic:	Open collector
Switching mode selector:	Manually selectable

Signal voltage PNP HIGH/LOW:	Approx. $V_S - 1.8 V / 0 V$
Output current $I_{max}$ :	$\leq 100 \text{ mA}$
Response time:	$\leq 25 \text{ ms}$ <sup>4)</sup>
Switching frequency:	$2,000 \text{ Hz}$ <sup>5)</sup>
Electrical connection:	Cable, 3-wire, 2 m <sup>6)</sup>
Cable material:	PVC
Circuit protection:::	A, B, D <sup>7) 8) 9)</sup>
Weight:	50 g
Polarisation filter:	✓
Housing material:	ABS, Plastic
Optics material:	PMMA
Enclosure rating:	IP 67
Items supplied:	Mounting bracket, included Mounting bracket, included, Reflector P250 and oblong washer for mounting
Ambient temperature operation:	$-25 \text{ }^\circ\text{C} \dots 55 \text{ }^\circ\text{C}$
Ambient storage temperature:	$-40 \text{ }^\circ\text{C} \dots 70 \text{ }^\circ\text{C}$

<sup>1)</sup> Limit values, operation in short-circuit protected network max. 8 A <sup>2)</sup> May not exceed or fall short of  $V_S$  tolerances <sup>3)</sup> Without load <sup>4)</sup> Signal transit time with resistive load <sup>5)</sup> With light/dark ratio 1:1 <sup>6)</sup> Do not bend below  $0 \text{ }^\circ\text{C}$  <sup>7)</sup> A =  $V_S$  connections reverse-polarity protected <sup>8)</sup> B = inputs and output reverse-polarity protected <sup>9)</sup> D = outputs overcurrent and short-circuit protected

### Dimensional drawing

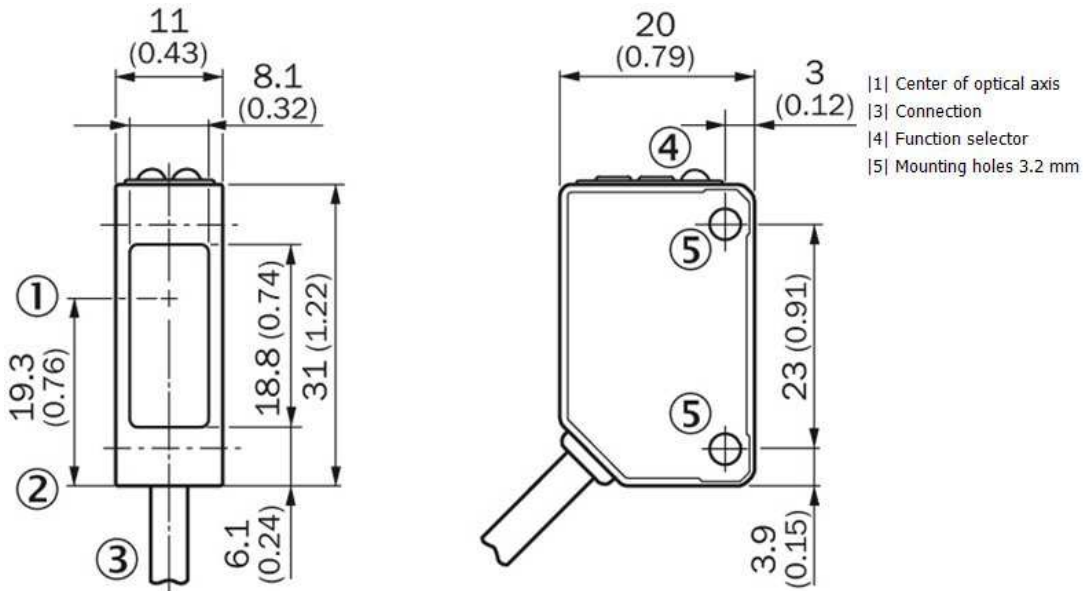

**Adjustments possible**

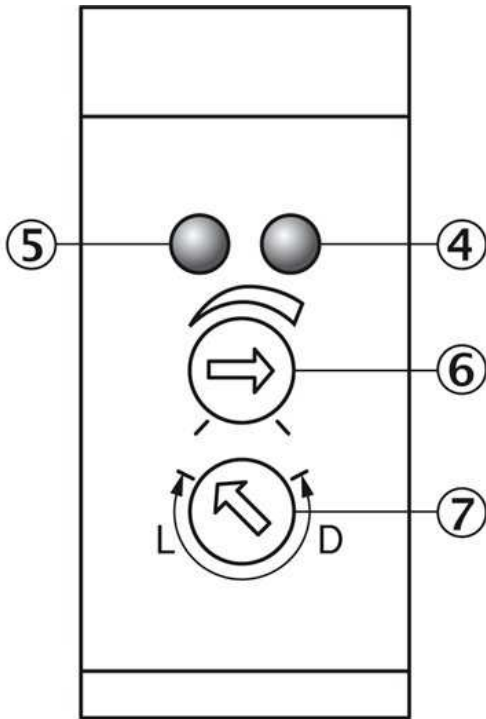

- |4| Orange LED indicator : switching output active
- |5| LED indicator green: stability indicator
- |6| Sensitivity adjustment
- |7| Light/ dark rotary switch L = light switching, D = dark switching

**Characteristic curve**

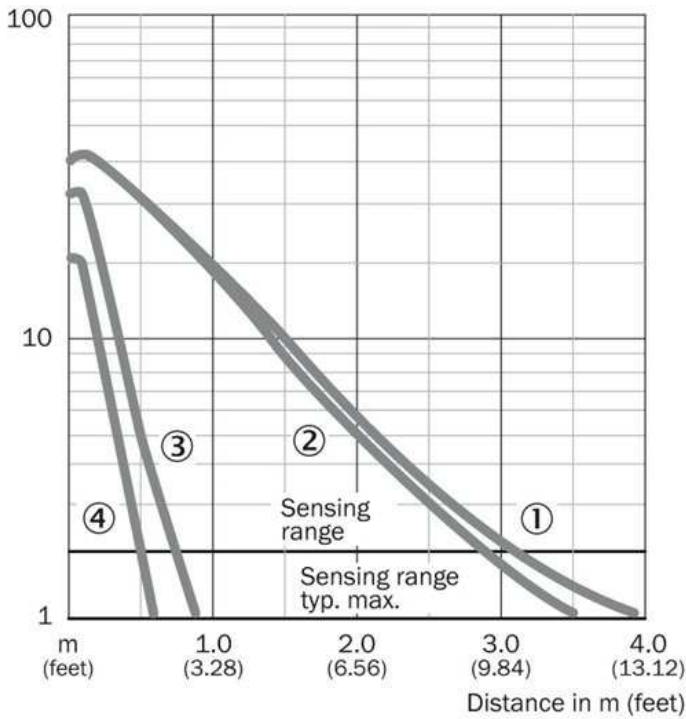

- |1| PL80A
- |2| P250
- |3| P45
- |4| Reflective tape Diamond Grade

## Sensing range diagram

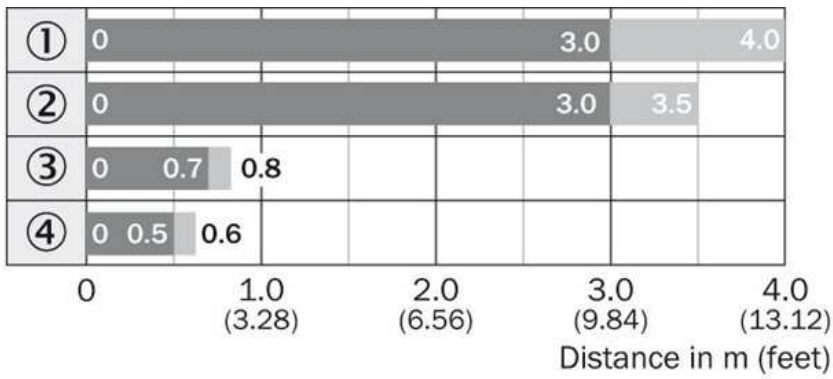

- |1| PL80A
- |2| P250
- |3| P45
- |4| Reflective tape Diamond Grade

■ Sensing range      ■ Sensing range typ. max.

## Reflector type

- ① PL80A
- ② P250
- ③ P45
- ④ Diamond Grade

**Australia**

Phone +61 3 9457 0600  
1800 33 48 02 – tollfree  
E-Mail sales@sick.com.au

**Belgium/Luxembourg**

Phone +32 (0)2 466 55 66  
E-Mail info@sick.be

**Brasil**

Phone +55 11 3215-4900  
E-Mail marketing@sick.com.br

**Canada**

Phone +1 905 771 14 44  
E-Mail information@sick.com

**Česká republika**

Phone +420 2 57 91 18 50  
E-Mail sick@sick.cz

**China**

Phone +86 4000 121 000  
E-Mail info.china@sick.net.cn  
Phone +852-2153 6300  
E-Mail ghk@sick.com.hk

**Danmark**

Phone +45 45 82 64 00  
E-Mail sick@sick.dk

**Deutschland**

Phone +49 211 5301-301  
E-Mail info@sick.de

**España**

Phone +34 93 480 31 00  
E-Mail info@sick.es

**France**

Phone +33 1 64 62 35 00  
E-Mail info@sick.fr

**Great Britain**

Phone +44 (0)1727 831121  
E-Mail info@sick.co.uk

**India**

Phone +91-22-4033 8333  
E-Mail info@sick-india.com

**Israel**

Phone +972-4-6881000  
E-Mail info@sick-sensors.com

**Italia**

Phone +39 02 27 43 41  
E-Mail info@sick.it

**Japan**

Phone +81 (0)3 5309 2112  
E-Mail support@sick.jp

**Magyarország**

Phone +36 1 371 2680  
E-Mail office@sick.hu

**Nederland**

Phone +31 (0)30 229 25 44  
E-Mail info@sick.nl

**Norge**

Phone +47 67 81 50 00  
E-Mail sick@sick.no

**Österreich**

Phone +43 (0)22 36 62 28 8-0  
E-Mail office@sick.at

**Polska**

Phone +48 22 837 40 50  
E-Mail info@sick.pl

**România**

Phone +40 356 171 120  
E-Mail office@sick.ro

**Russia**

Phone +7-495-775-05-30  
E-Mail info@sick.ru

**Schweiz**

Phone +41 41 619 29 39  
E-Mail contact@sick.ch

**Singapore**

Phone +65 6744 3732  
E-Mail sales.gsg@sick.com

**Slovenija**

Phone +386 (0)1-47 69 990  
E-Mail office@sick.si

**South Africa**

Phone +27 11 472 3733  
E-Mail info@sickautomation.co.za

**South Korea**

Phone +82 2 786 6321/4  
E-Mail info@sickkorea.net

**Suomi**

Phone +358-9-25 15 800  
E-Mail sick@sick.fi

**Sverige**

Phone +46 10 110 10 00  
E-Mail info@sick.se

**Taiwan**

Phone +886 2 2375-6288  
E-Mail sales@sick.com.tw

**Türkiye**

Phone +90 (216) 528 50 00  
E-Mail info@sick.com.tr

**United Arab Emirates**

Phone +971 (0) 4 88 65 878  
E-Mail info@sick.ae

**USA/México**

Phone +1(952) 941-6780  
1 (800) 325-7425 – tollfree  
E-Mail info@sickusa.com

More representatives and agencies  
at [www.sick.com](http://www.sick.com)