

Analogue limit monitor for top hat rail mounting

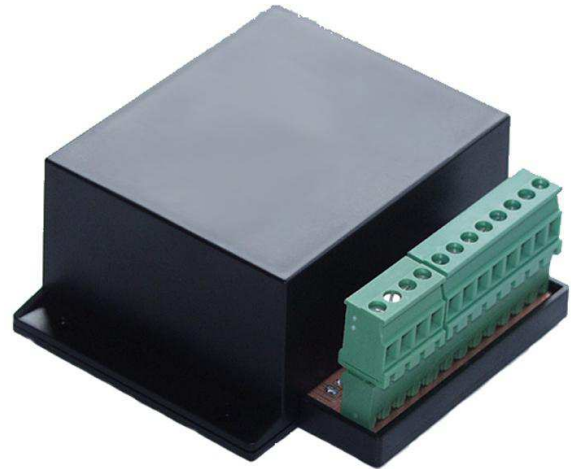

Description

Designed to avoid overload in hoists, elevators, cranes and building machines.

The overload protection device possesses:

- 1 sensor input, 4 - 20 mA
- 3 comparators with one adjusting potentiometer each
- each comparator triggers 1 relay and 1 control LED
- each relays can be used as „on“ or „off“ switch
- a 4th comparator which switches all relays into overload mode in case of a cable disruption

Force transducers for this overload protection: all types with 4...20mA are connectable.

Features

- Limit monitor for standard signal 4...20 mA
- 3 relay outputs
- Simple handling and setting
- Setting regular for switching thresholds
- Robust housing for top hat rail mounting
- Can also be used in tough conditions

Applications

- overload in hoists
- cranes
- elevators
- building machines

Model: EGS08

Technical data

Model	EGS08
Output	
- Relay outputs	3
- Accuracy	0.3%
Input	
- Signal	1 ... 9 mA or 4 ... 20 mA
- Sensor supply	21 VDC, max. 50 mA
- Filter setting	weak: approx. 1 ms cut-in delay medium: approx. 10 ms cut-in delay strong: approx. 20 ms cut-in delay
Setting	
- Relay outputs	Continuously adjustable via potentiometer
Power requirement	24VDC (-10%/+40%) max. 100 mA AC or DC adjustable with solder bridges
Nominal temperature range	+10 ... +40°C
Service temperature range	0 ... +60°C
Storage temperature range	-10 ... +70°C
Burden resistor	360 Ω or 180 Ω
Cable disruption detection	release relay function as of 0.7 mA signal current at 1-9 mA burden as of 1.4 mA signal current at 4-20 mA burden
Protection type (acc. to EN 60 529/IEC 529)	IP 40
Electrical connection	Screw terminals
Housing	For top hat rails acc. to DIN EN 50 022
- Material	Plastic
- Dimensions (W x H x D)	approx. 67 x 80 x 41 mm (Diagonal 45* 89 mm)
Fastening housing	drill hole diameter 3,2 mm

Terminal Assignment

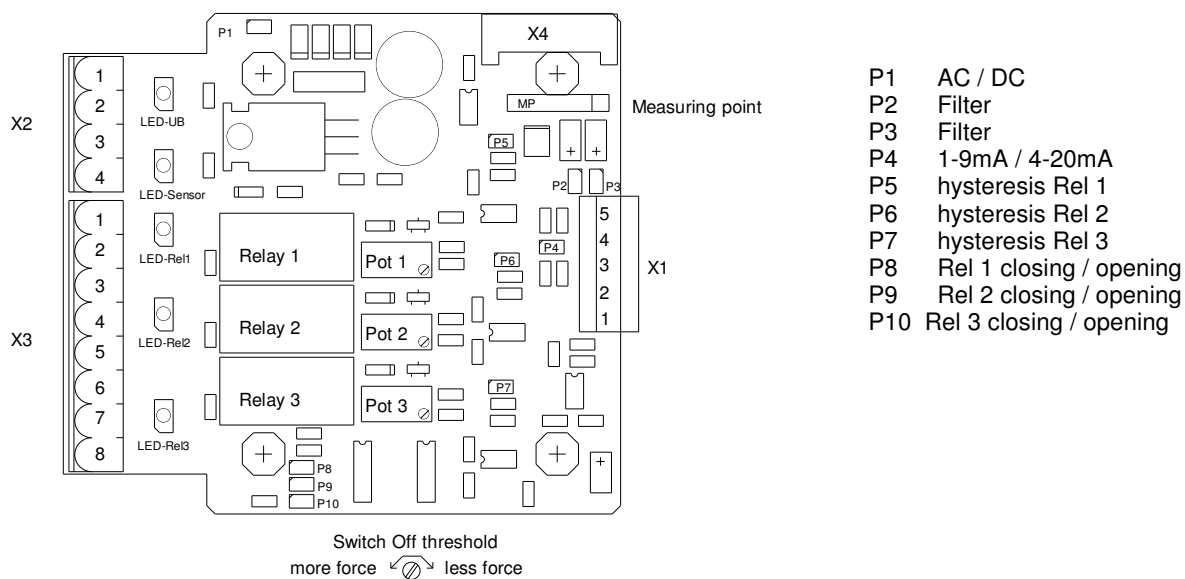

Connecting clamp X1

Pin	description	Cable colour	Pin
1	UB	Excitation Load Cell 21VDC (internal generate)	1
2	GND	Ground	2
3	Im	Output Load Cell 1-9mA oder 4-20mA	3
4	not used		4
5	protect	protection of the connection cable against emc	5

4-20mA 2-wire, only connecting clamp 1 and 3 with UB+/S+ and 0V/S- are added

Connecting clamp X2

Pin	description	potentiometer
1	24 VAC Power supply or +24 VDC	
2	24 VAC Power supply or 24 VDC (GND)	
3	not used	
4	Ground	

Connecting clamp X3

Pin	description	potentiometer
1	Relay 1, make contact	
2	Relay 1, middle contact	POT 1
3	Relay 2, make contact	
4	Relay 2, home contact	
5	Relay 2, middle contact	POT 2
6	Relay 3, make contact	
7	Relay 3, home contact	
8	Relay 3, middle contact	POT 3

Force / Voltage diagram for overload detection

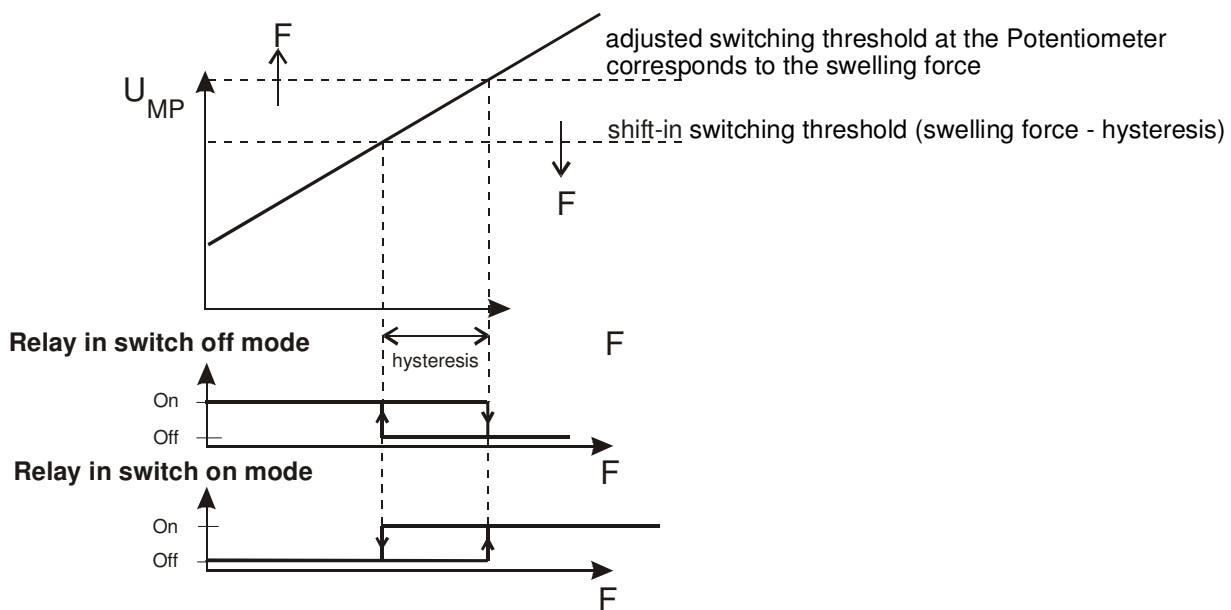

Connection tectis force transducers with output signal 4...20mA (2 wire) and SIL3 test relay

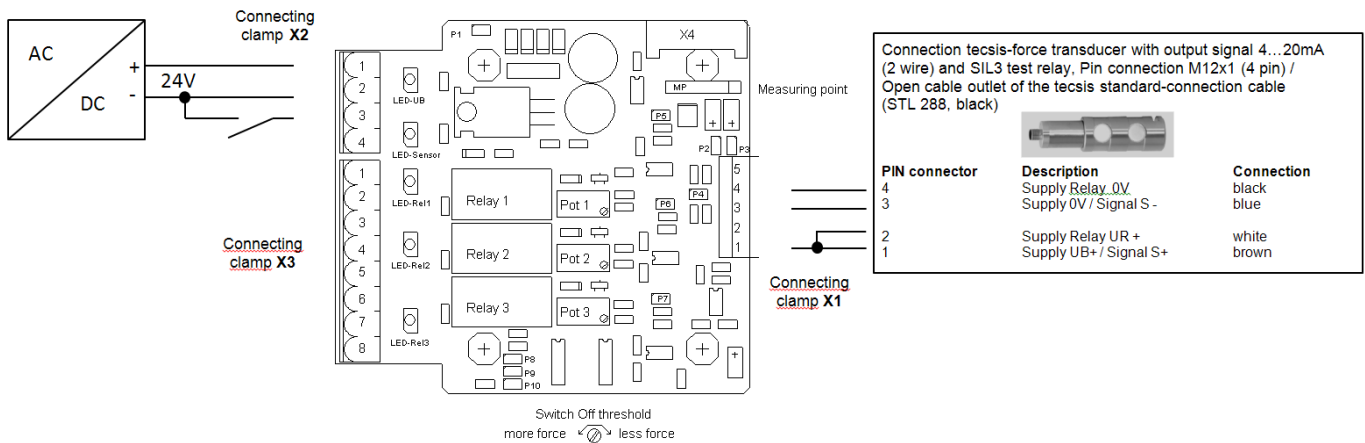

When using tectis force transducer with test relay (4... 20mA – 2 wire for SIL3-application), by the connection of the contact clamp 3 at the connection port X2 (activation test relay for signal leap) is released by the factory with the mass (GND), that at the force receiver after customer's request stopped signal leap.

The standard settings of the force transducer with current exit 4... 20 mA for overload detection e.g. is:

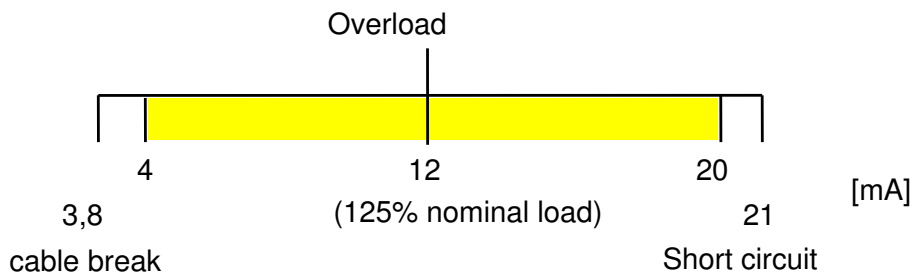

With a firmly stopped signal deviation of 8 mA in each operating condition on activation of the test relay the point of overload is then exceeded. The upper measuring range border of 20 mA is not reached however and thus the examination of the signal deviation is made possible (see in addition for further information also the data sheets of the appropriate tectis force transducers).

Connecting clamp X1 for 3 wire

Pin	Description	Note
1	UB	excitation Load Cell 21VDC (internal generate)
2	GND	ground
3	Im	sensor signal 1-9mA or 4-20mA
4	--	--
5	protect	protection of the connection cable against emc

Connecting clamp X1 for 2 wire

Pin	Description	Note	Connection tectsis-force transducer with output signal 4...20mA (2 wire) and SIL3 test relay Pin connection M12x1 (4 pin) / Open cable outlet of the tectsis standard-connection cable (STL 288, black)		
			PIN M12x1	Description	Connection
1	UB	supply voltage sensor and relay 21VDC (produced internally)	1 and 2	supply. UB+ / signal S+ supply relay. UR +	brown white
3	Im	sensor signal 1-9mA or 4-20mA	3	supply. 0V / signal S -	blue
4	signal deviation	supply relay 0 V	4	supply relay 0V	black
5	protect	protection of the connection cable against emc	thread M12x1	protect	protect

Connecting clamp X2

Pin.	Description	Controller
1	24 VAC voltage output or +24 VDC supply	
2	24 VAC volatge output or 24 VDC supply (GND)	
3	Activation test relay for signal leap (with connection the mass (GND))	
4	mass	

Connecting clamp X3

Pin.	Description	Controller
1	Relay 1, operating contact	
2	Relay 1, center contact	POT 1
3	Relay 2, operating contact	
4	Relay 2, de-energised conact	
5	Relay 2, center contact	POT 2
6	Relay 3, operating contact	
7	Relay 3, de-energised conact	
8	Relay 3, center contact	POT 3

Subject to technical alternations