

2 – channel Digital indicator for strain transducers



GENERAL DESCRIPTION

The E1931X402 Dual Process Input Meter offers many features and performance capabilities to suit a wide range of industrial applications. Available in two models, AC or DC power, the meter has the capability to accept two, 4 to 20 mA or 0 to 10 VDC input signals. Each input signal can be independently scaled and displayed. In addition, a math function can be performed on the two signals, $C + A + B$, $C - A - B$, $C + A - B$, AB / C , CA / B , or $C (A / B - 1)$. Any of the three meter values can have Alarms, Comms, and/or a Retransmitted Analog Output capability by simply adding optional cards. The optional plug-in output cards allow the opportunity to configure the meter for current applications, while providing easy upgrades for future needs.

The update rate of the meter is user selectable. This will help in those applications where a quick response from the meter is of the utmost importance. The rate can be adjusted from eight selections with a minimum of 5 updates/second to a maximum of 105 updates/second. The meters employ a bright 0.56" (14.2 mm) red sunlight readable LED display. The intensity of display can be adjusted from dark room applications up to sunlight readable, making it ideal for viewing in bright light applications.

The meters provide a MAX and MIN reading memory with programmable capture time. The capture time is used to prevent detection of false max or min readings which may occur during start-up or unusual process events. The signal totalizer (integrator) can be used to compute a time-input product. This can be used to provide a readout of totalized flow, calculate service intervals of motors or pumps, etc. The totalizer can also accumulate batch operations.

The meter has four setpoint outputs, implemented on Plug-in option cards. The Plug-in cards provide dual FORM-C relays (5A), quad FORM-A (3A), or either quad sinking or quad sourcing open collector logic outputs. The setpoint alarms can be configured to suit a variety of control and alarm requirements. Communication and Bus Capabilities are also available as option cards. The standard output is in Modbus Protocol. Any of the following option cards, RS232, RS485, DeviceNet, or Probus can be used with the meter. Readout values and setpoint alarm values can be controlled through the bus. Additionally, the meters have a feature that allows a remote computer to directly control the outputs of the meter.

A linear DC output signal is available as an optional Plug-in card. The card provides either 20 mA or 10 V signals. The output can be scaled independent of the input range and can track either the input, totalizer, max/min readings, or math calculation value. Once the meters have been initially configured, the parameter list may be locked out from further modification in its entirety or only the setpoint values can be made accessible. The meters have been specifically designed for harsh industrial environments.

With NEMA 4X/IP65 sealed bezel and extensive testing of noise effects to CE requirements, the meter provides a tough yet reliable application solution.

FEATURES

- ACCEPTS TWO 4 - 20 mA OR 0 - 10 VDC INPUT SIGNALS
- PROGRAMMABLE A/D CONVERSION RATE, 5 TO 105
- READINGS PER SECOND
- 5-DIGIT 0.56" RED SUNLIGHT READABLE DISPLAY
- VARIABLE INTENSITY DISPLAY
- LINEARIZATION/SQUARE ROOT EXTRACTION INPUT RANGE
- PROGRAMMABLE FUNCTION KEYS/USER INPUTS
- 9 DIGIT TOTALIZER (INTEGRATOR) WITH BATCHING
- OPTIONAL CUSTOM UNITS OVERLAY W/BACKLIGHT
- FOUR SETPOINT ALARM OUTPUTS (W/OPTION CARD)
- COMMUNICATION AND BUS CAPABILITIES (W/OPTION CARD)
- RETRANSMITTED ANALOG OUTPUT (W/OPTION CARD)
- NEMA 4X/IP65 SEALED FRONT BEZEL
- PC SOFTWARE AVAILABLE FOR METER CONFIGURATION

SAFETY SUMMARY

All safety related regulations, local codes and instructions that appear in this literature or on equipment must be observed to ensure personal safety and to prevent damage to either the instrument or equipment connected to it. If equipment is used in a manner not specified by the manufacturer, the protection provided by the equipment may be impaired. Do not use this unit to directly command motors, valves, or other actuators not equipped with safeguards. To do so can be potentially harmful to persons or equipment in the event of a fault to the unit.



Model no.: E1931X402

Technical data

1. DISPLAY :

5 digit, 0.56" (14.2 mm) variable intensity red sunlight readable (-19999 to 99999)

2. POWER :

AC Versions:
 AC Power: 85 to 250 VAC, 50/60 Hz, 21 VA
 Isolation: 2300 Vrms for 1 min. to all inputs and outputs.
 DC Versions: (Derate operating temperature to 40° C if three plug-in option cards are installed.)
 DC Power: 18 to 36 VDC, 13 W
 AC Power: 24 VAC, ± 10%, 50/60 Hz, 16 VA
 Isolation: 500 Vrms for 1 min. to all inputs and outputs (50 V working).
 Must use a Class 2 or SELV rated power supply

3. ANNUNCIATORS :

A - Programmable Display
 B - Programmable Display
 C - Programmable Display
 SP1 - Setpoint alarm 1 is active
 SP2 - Setpoint alarm 2 is active
 SP3 - Setpoint alarm 3 is active
 SP4 - Setpoint alarm 4 is active
 Units Label - Optional units label backlight

4. **KEYPAD** : 3 programmable function keys, 5 keys total

5. **A/D CONVERTER** : 16 bit resolution

6. UPDATE RATES :

A/D conversion rate: Adjustable 5.3 to 105 readings/sec.
 Step response: (to within 99% of final readout value with digital filter disabled)

INPUT UPDATE RATE	MAX. TIME (msec)
5.3	770
7.5	560
16.7	260
19.8	220
20	220
30	150
105	60

Display update rate: adjustable 1 to 20 readings/sec.
 Setpoint output on/off delay time: 0 to 3275 sec.
 Analog output update rate: 0 to 10 sec
 Max./Min. capture delay time: 0 to 3275 sec.

7. DISPLAY MESSAGES :

"LOL" - Appears when measurement exceeds + signal range.
 "ULUL" - Appears when measurement exceeds - signal range
 ". . . ." - Appears when display values exceed + display range.
 "- . . ." - Appears when display values exceed - display range.

8. SENSOR INPUTS :

INPUT (RANGE)	ACCURACY * (18 to 28°C)	ACCURACY* (0 to 50°C)	IMPEDANCE/ COMPLIANCE	MAX CONTINUOUS OVERLOAD	DISPLAY RESOLUTION
±20 mA (-26 to 26 mA)	0.03% of reading +2 µA	0.12% of reading +3 µA	24.6 ohm	90 mA	1 µA
±10 VDC (-13 to 13 VDC)	0.03% of reading +2 mV	0.12% of reading +3 mV	500 Kohm	50 V	1 mV

* After 20 minute warm-up. Accuracy is specified in two ways: Accuracy over an 18 to 28°C and 10 to 75% RH environment; and accuracy over a 0 to 50°C and 0 to 85% RH (non-condensing environment). Accuracy over the 0 to 50°C range includes the temperature coefficient of the meter.

9. EXCITATION POWER :

Transmitter Power: 18 VDC, ±20%, unregulated, 70 mA max. per input channel.

10. LOW FREQUENCY NOISE REJECTION :

Normal Mode: (digital filter on)

INPUT UPDATE RATE	50 Hz ±1 Hz	60 Hz ±1 Hz
5.3	>90 dB	>65 dB
7.5	>60 dB	>55 dB
16.7	>100 dB	>50 dB
19.8*	>60 dB	>95 dB
20	>55 dB	>100 dB
30	>20 dB	>20 dB
105	>20 dB	>13 dB

*Note: 19.8 Hz Input Rate provides best rate performance and simultaneous 50/60 Hz rejection.
 Common Mode: >100 dB @ 50/60 ±1 Hz (19.8 or 20 Input Rate)

11. USER INPUTS :

Three programmable user inputs
 Max. Continuous Input: 30 VDC
 Isolation To Sensor Input A Common: 500 Vrms for 1 min;
 Working Voltage: 50 V
 Isolation To Sensor Input B Common: Not isolated.

INPUT STATE	SINKING INPUTS		SOURCING INPUTS	
	22 K Ω pull-up to +5 V		22 K Ω pull-down	
Active	$V_{IN} < 0.9$ VDC	$V_{IN} > 3.6$ VDC		
Inactive	$V_{IN} > 3.6$ VDC	$V_{IN} < 0.9$ VDC		

Response Time: 20 msec. max.
 Logic State: Jumper selectable for sink/source logic

12. TOTALIZER :

Function:
 Time Base: second, minute, hour, or day
 Batch: Can accumulate (gate) input display from a user input
 Time Accuracy: 0.01% typical
 Decimal Point: 0 to 0.0000
 Scale Factor: 0.001 to 65.000
 Low Signal Cut-out: -19,999 to 99,999
 Total: 9 digits, display alternates between high order and low order readouts

13. CUSTOM LINEARIZATION :

Data Point Pairs: Selectable from 2 to 16
 Display Range: -19,999 to 99,999
 Decimal Point: 0 to 0.0000

14. MEMORY :

Nonvolatile memory retains all programmable parameters and display values.

15. CERTIFICATIONS AND COMPLIANCES : SAFETY

UL Recognized Component, File #E179259, UL6101A-1, CSA C22.2 No. 1010-1
 Recognized to U.S. and Canadian requirements under the Component Recognition Program of Underwriters Laboratories, Inc.
 UL Listed, File #E137808, UL508, CSA C22.2 No. 14-M95 LISTED by Und. Lab. Inc. to U.S. and Canadian safety standards
 Type 4X Enclosure rating (Face only), UL50
 IEC CB Scheme Test Certificate #US/8843A/UL
 CB Scheme Test Report #04ME11209-20041018
 Issued by Underwriters Laboratories, Inc.
 IEC 61010-1, EN 61010-1: Safety requirements for electrical equipment for measurement, control, and laboratory use, Part 1.
 IP65 Enclosure rating (Face only), IEC 529
 IP20 Enclosure rating (Rear of unit), IEC 529
 Torque: 4.5 inch-lbs (0.51 N-m) max.

15. CERTIFICATIONS AND COMPLIANCES (Cont'd) :

ELECTROMAGNETIC COMPATIBILITY
 Emissions and Immunity to EN 61326: Electrical Equipment for Measurement, Control and Laboratory use.

Immunity to Industrial Locations:		
Electrostatic discharge	EN 61000-4-2	Criterion A 4 kV contact discharge 8 kV air discharge
Electromagnetic RF fields	EN 61000-4-3	Criterion A 10 V/m
Fast transients (burst)	EN 61000-4-4	Criterion A 2 kV power 1 kV signal
Surge	EN 61000-4-5	Criterion A 1 kV L-L, 2 kV L&N-E power
Voltage dip/interruptions	EN 61000-4-11	Criterion A 0.5 cycle
RF conducted interference	EN 61000-4-6	Criterion A 3 V/rms
Emissions:		
AC powered	EN 55011	Class B
DC powered	EN 55011	Class A

Notes:

1. Criterion A: Normal operation within specified limits.
2. Criterion B: Temporary loss of performance from which the unit selfrecovers. Refer to EMC Installation Guidelines section of the bulletin for additional information.

16. ENVIRONMENTAL CONDITIONS :

Operating Temperature Range: 0 to 50°C (0 to 45°C with all three plug-in option cards installed)
 Storage Temperature Range: -40 to 60°C
 Operating and Storage Humidity: 0 to 85% max. RH non-condensing
 Altitude: Up to 2000 meters

17. CONNECTIONS :

High compression cage-clamp terminal block
 Wire Strip Length: 0.3" (7.5 mm)
 Wire Gauge: 30-14 AWG copper wire
 Torque: 4.5 inch-lbs (0.51 N-m) max.

18. CONSTRUCTION :

This unit is rated for NEMA 4X/IP65 outdoor use.
 IP20 Touch safe. Installation Category II, Pollution Degree 2. One piece bezel/case. Flame resistant. Synthetic rubber keypad. Panel gasket and mounting clip included.

19. **WEIGHT** : 10.4 oz. (295 g)

DIMENSIONS In inches (mm)

Note: Recommended minimum clearance (behind the panel) for mounting clip installation is 2.1" (53.4) H x 5.0" (127) W.

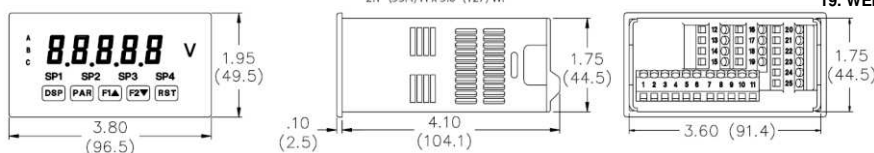

2. Installing the meter

Installation

The meter meets NEMA 4X/IP65 requirements when properly installed. The unit is intended to be mounted into an enclosed panel. Prepare the panel cutout to the dimensions shown. Remove the panel latch from the unit. Slide the panel gasket over the rear of the unit to the back of the bezel. The unit should be installed fully assembled. Insert the unit into the panel cutout. While holding the unit in place, push the panel latch over the rear of the unit so that the tabs of the panel latch engage in the slots on the case. The panel latch should be engaged in the farthest forward slot possible. To achieve a proper seal, tighten the latch screws evenly until the unit is snug in the panel (Torque to approximately 7 in-lbs [79N-cm]). Do not over-tighten the screws.

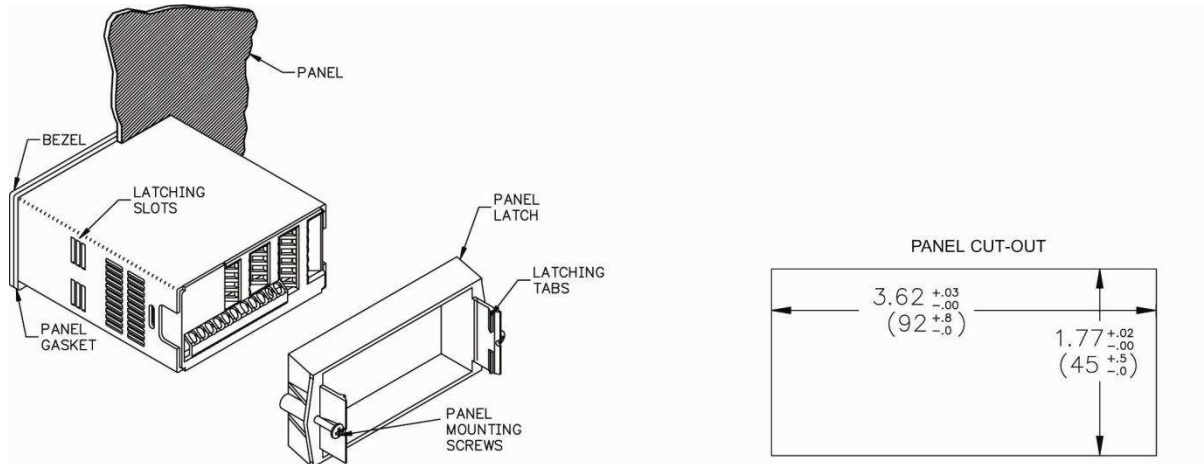

Installation Environment

The unit should be installed in a location that does not exceed the maximum operating temperature and provides good air circulation. Placing the unit near devices that generate excessive heat should be avoided. The bezel should be cleaned only with a soft cloth and neutral soap product. Do NOT use solvents. Continuous exposure to direct sunlight may accelerate the aging process of the bezel. Do not use tools of any kind (screwdrivers, pens, pencils, etc.) to operate the keypad of the unit.

3. Reviewing the front buttons and display

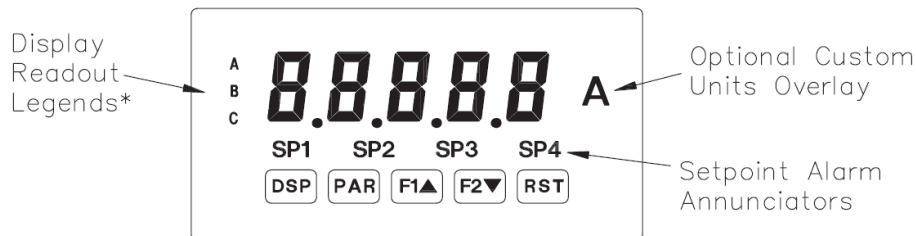

KEY DISPLAY MODE OPERATION

DSP	Index display through main displays as programmed in	3-LOC
PAR	Access parameter list	
F1 ▲	Function key 1; hold for 3 seconds for Second Function 1	**
F2 ▼	Function key 2; hold for 3 seconds for Second Function 2	**
RST	Reset (Function key)	**

* Display Readout Legends may be locked out in Factory Settings.

** Factory setting for the F1, F2, and RST keys is NO mode.

PROGRAMMING MODE OPERATION

	Quit programming and return to display mode
	Store selected parameter and index to next parameter
	Increment selected parameter value
	Decrement selected parameter value
	Hold with F1 ▲, F2 ▼ to scroll value by x1000

4. Accessories

UNITS LABEL KIT

Each meter has units indicator with backlighting that can be customized using the Units Label Kit. The backlight is controlled in the programming.

5. Optional plug-in output cards

The E1931X402 series meters can be fitted with up to three optional plug-in cards. The details for each plug-in card can be reviewed in the specification section below. Only one card from each function type can be installed at one time. The function types include Setpoint Alarms, Communications and Analog Output. The plug-in cards can be installed initially or at a later date.

Communication cards

A variety of communication protocols are available for the E1931X402 series. Only one of these cards can be installed at a time.

Note: For Modbus communications use RS485 Communications Output Card and configure communication (TYPE) parameter for Modbus.

- RS485 Serial (Terminal Block)
- DeviceNet
- RS232 Serial (Terminal Block)
- RS485 Serial (Dual RJ11 Connector)
- Proibus-DP
- RS232 Serial (9 Pin D Connector)

SERIAL COMMUNICATIONS CARD

Type: RS485 or RS232

Isolation To Sensor & User Input Commons : 500 Vrms for 1 min.
Working Voltage: 50 V. Not Isolated from all other commons.
Baud : 300 to 38,400
Data: 7/8 bits
Parity : no, odd or even
Bus Address : Selectable 0 to 99 (RLC Protocol), or 1 to 247 (Modbus Protocol), Max. 32 meters per line (RS485)
Transmit Delay : Selectable for 0 to 0.250 sec (+2 msec min)

DEVICENET™ CARD

Compatibility : Group 2 Server Only, not UCMM capable
Baud Rates : 125 Kbaud, 250 Kbaud, and 500 Kbaud
Bus Interface : Phillips 82C250 or equivalent with MIS wiring protection per DeviceNet™ Volume I Section 10.2.2.
Node Isolation : Bus powered, isolated node
Host Isolation : 500 Vrms for 1 minute (50 V working) between DeviceNet™ and meter input common.

PROFIBUS-DP CARD

Fieldbus Type: Pro_bus-DP as per EN 50170, implemented with Siemens SPC3 ASIC
Conformance: PNO Certified Pro_bus-DP Slave Device
Baud Rates: Automatic baud rate detection in the range 9.6 Kbaud to 12 Mbaud
Station Address: 0 to 126, set by the master over the network.
Address stored in non-volatile memory.
Connection: 9-pin Female D-Sub connector
Network Isolation: 500 Vrms for 1 minute (50 V working) between Proibus network and sensor and user input commons. Not isolated from all other commons.

SETPOINT CARDS

The E1931X402 series has 4 available setpoint alarm output plug-in cards. Only one of these cards can be installed at a time. (Logic state of the outputs can be reversed in the programming.) These plug-in cards include:

- Dual Relay, FORM-C, Normally open & closed
- Quad Relay, FORM-A, Normally open only
- Isolated quad sinking NPN open collector
- Isolated quad sourcing PNP open collector

DUAL RELAY CARD

Type : Two FORM-C relays
Isolation To Sensor & User Input Commons : 2000 Vrms for 1 min.
Working Voltage: 240 Vrms

Contact Rating :

One Relay Energized: 5 amps @ 120/240 VAC or 28 VDC (resistive load),
1/8 HP @120 VAC, inductive load
Total current with both relays energized not to exceed 5 amps
Life Expectancy : 100 K cycles min. at full load rating. External RC snubber extends relay life for operation with inductive loads

QUAD RELAY CARD

Type : Four FORM-A relays
Isolation To Sensor & User Input Commons : 2300 Vrms for 1 min.
Working Voltage: 250 Vrms
Contact Rating :
One Relay Energized: 3 amps @ 240 VAC or 30 VDC (resistive load), 1/10 HP @120 VAC, inductive load
Total current with all four relays energized not to exceed 4 amps
Life Expectancy : 100 K cycles min. at full load rating. External RC snubber extends relay life for operation with inductive loads

QUAD SINKING OPEN COLLECTOR CARD

Type : Four isolated sinking NPN transistors.
Isolation To Sensor & User Input Commons : 500 Vrms for 1 min.
Working Voltage: 50 V. Not Isolated from all other commons.
Rating : 100 mA max @ V SAT = 0.7 V max. V MAX = 30 V

QUAD SOURCING OPEN COLLECTOR CARD

Type : Four isolated sourcing PNP transistors.
Isolation To Sensor & User Input Commons : 500 Vrms for 1 min.
Working Voltage: 50 V. Not Isolated from all other commons.
Rating : Internal supply: 24 VDC ± 10%, 30 mA max. total
External supply: 30 VDC max., 100 mA max. each output

ALL FOUR SETPOINT CARDS

Response Time : See update rates step response specification;
add 6 msec (typical) for relay card

LINEAR DC OUTPUT

Either a 0(4)-20 mA or 0-10 V retransmitted linear DC output is available from the analog output plug-in card. The programmable output low and high scaling can be based on various display values. Reverse slope output is possible by reversing the scaling point positions.
- Retransmitted Analog Output Card

ANALOG OUTPUT CARD

Types : 0 to 20 mA, 4 to 20 mA or 0 to 10 VDC
Isolation To Sensor & User Input Commons : 500 Vrms for 1 min.
Working Voltage: 50 V. Not Isolated from all other commons.
Accuracy : 0.17% of FS (18 to 28°C); 0.4% of FS (0 to 50°C)
Resolution : 1/3500
Compliance: 10 VDC: 10 K Ω load min., 20 mA: 500 Ω load max.
Update time: See update rates step response specification

Type	Order No.
Serial communication card RS 485 / RS 422	A5753X002001
Serial communication card RS 232	A5753X002002
Analogue output card	A5753X002005
Dual relay card	A5753X002006
Quad relay card	A5753X002007
Quad sinking open collector card (4 x NPN)	A5753X002008
Quad sourcing open collector card (4 x PNP)	A5753X002009
Housing IP65 for 96x46 Informators	EZM45X001006