

**Actuator/sensor cable, PUR  
extension cable  
PKW4M-P7X2-4-RSC4.4T/TXL**

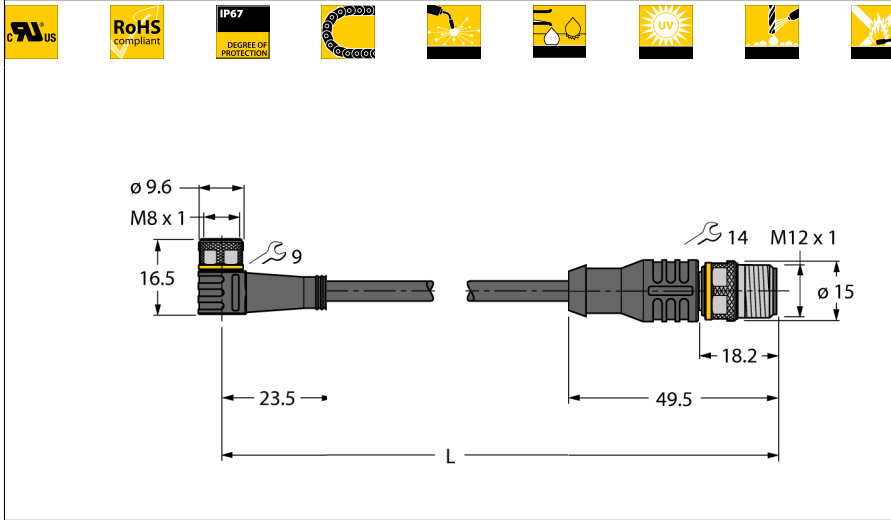

- Female M8, angled, 4-pin
- With 2-color LED (PNP, yellow, green)
- Male M12, straight, 4-pin
- Sheath material: PUR
- Sheath color: black
- Qualified for drag chain use
- Resistant to weld splatter
- Resistant to chemicals, UV radiation and oils
- Flame retardant
- Free from halogen, silicone, PVC and LABS
- Particularly resistant to abrasion
- Approval: cULus
- RoHS conform
- Protection class IP67
- Cable length: 4.0 m

**Type code** PKW4M-P7X2-4-RSC4.4T/TXL  
**Ident no.** 6625831

**Connector A side**  
 Number of Pins 4  
 Contacts brass, CuZn, gold-plated  
 Contact carriers plastic, TPU, black  
 Grip Plastic, TPU, black  
 Coupling nut/screw brass, CuZn, nickel-plated  
 Seal plastic, FPM/FKM  
 Protection class IP67, A + B side screwed together  
 Operating voltage LED green  
 Display switch state LED yellow  
 Mechanical lifespan > 100 mating cycles  
 Pollution degree 3  
 Tightening torque 0.5 ... 0.6 Nm  
 (observe max. torque of counter piece!)

**Connector B side**  
 Number of pins 4 pins  
 Contacts brass, CuZn, gold-plated  
 Contact carriers plastic, TPU, black  
 Grip plastic, TPU  
 Coupling nut/screw brass, CuZn, nickel-plated  
 Protection class IP67, only in screwed state  
 Mechanical lifespan > 100 contact durability  
 Pollution degree 3  
 Tightening torque 0.8 ... 1 Nm  
 (observe max. torque of counter piece!)

**General data**  
 Cable diameter 4.7 +/-0.20mm  
 Cable length 4 m  
 Cable Jacket Material PUR  
 Cable Jacket Color black  
 Core insulation PP  
 Core colors BN, WH, BU, BK  
 Core cross-section 4x0.34mm<sup>2</sup>  
 Arrangement of strands 42x0.1 mm

**Electrical features at +20 °C**  
 Ampacity 4 A  
 Rated Voltage 30 V  
 Insulation resistance > 30.5 MΩ/km  
 Test voltage 2000 V  
 Forward resistance max. 57 Ω/km

**Cable Cross-section**

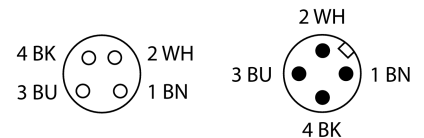
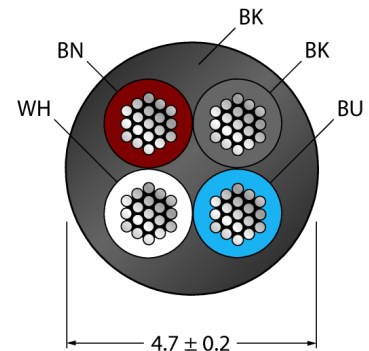

**General information**

Drawing depicts design version including hexagon coupling nut  
(Production date after CW11/2016).

**Circuit diagram**

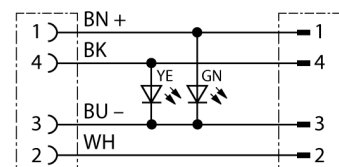

**Actuator/sensor cable, PUR  
extension cable  
PKW4M-P7X2-4-RSC4.4T/TXL**

**TURCK**

Industrial  
Automation

---

**Mechanical and chemical properties**

Max. tensile strength (static)	≤ 50 N/mm <sup>2</sup>
Max. tensile strength (dynamic)	≤ 20 N/mm <sup>2</sup>
Bending cycles	> 5 mil.
Bending radius (stationary laying)	> 5 x Ø
Bending radius (flexible use)	> 10 x Ø
Admissible acceleration	max. 5 m/s <sup>2</sup>
Admissible travel path, horizontal	5 m (at 5 m/s <sup>2</sup> )
Admissible travel path, vertical	2 m (at 5 m/s <sup>2</sup> )
Admissible traversing speed	3.3 m/s
Torsional stress	± 180 °/m
Ambient temperature	
Stationary	-50 ... 80°C
In motion	-25 ... 80°C
Drag chain operation	-25 ... 60°C