

Diaphragm seal with sterile connection For homogeniser machines Model 990.30

WIKA data sheet DS 99.33



for further approvals
see page 6

Applications

- Homogeniser machines for milk, beverages, cosmetics and pharmaceutical preparations
- Machines for the production of emulsions

Special features

- Process connection with flush, all welded diaphragm, with or without retainer flange
- For highest dynamic pressures $\leq 2,500$ bar
- System fill fluids FDA and USP conform
- Robust, all welded design



Diaphragm seal model 990.30 with directly mounted Bourdon tube pressure gauge with electrical output signal model PGT23.100

Description

Diaphragm seals are used for the protection of pressure measuring instruments in applications with difficult media. In diaphragm seal systems, the diaphragm of the diaphragm seal effects the separation of the instrument and the medium. The pressure is transmitted to the measuring instrument via the system fill fluid which is inside the diaphragm seal system.

For the implementation of demanding customer applications, there are a wide variety of designs, materials and system fill fluids available.

For further technical information on diaphragm seals and diaphragm seal systems see IN 00.06 "Application, operating principle, designs".

The model 990.30 diaphragm seal is a special development for homogeniser machines in sanitary applications. This diaphragm seal is available with process connections in various designs and is thus suitable for all common measuring points. The diaphragm seal systems ensure reliable measurements, even with high loading through vibrations and pressure spikes.

Mounting of the diaphragm seal to the measuring instrument may be made via a direct connection or a flexible capillary.

For the material selection WIKA offers a variety of solutions, in which the upper body of the diaphragm seal and the wetted parts can be made of identical or different materials.







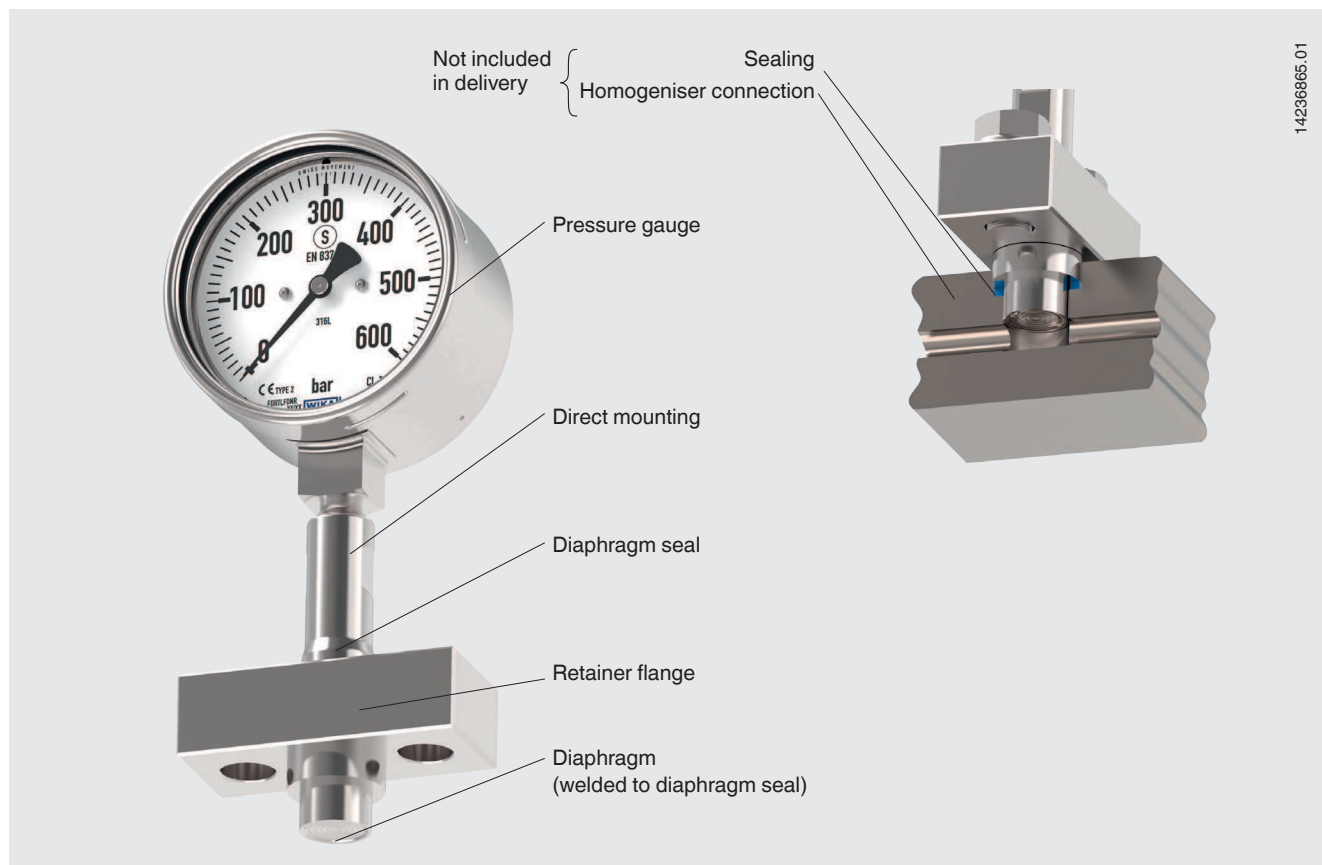

Specifications

Model 990.30	Standard	Option
Measuring ranges in bar (psi)	0 ... 160 bar (2,320 psi) 0 ... 250 bar (3,626 psi) 0 ... 400 bar (5,800 psi) 0 ... 600 bar (8,700 psi)	0 ... 1,000 bar (14,500 psi) 0 ... 1,600 bar (2,320 psi) 0 ... 2,500 bar (36,260 psi)
Measuring ranges in psi	0 ... 2,000 psi 0 ... 4,000 psi 0 ... 6,000 psi	0 ... 10,000 psi 0 ... 15,000 psi 0 ... 20,000 psi
Level of cleanliness of wetted parts	Oil and grease free per ASTM G93-03 level E (WIKA standard) and ISO 15001 (< 1,000 mg/m ²)	<ul style="list-style-type: none"> ■ Oil and grease free per ASTM G93-03 level D and ISO 15001 (< 220 mg/m²) ■ Oil and grease free per ASTM G93-03 level C and ISO 15001 (< 66 mg/m²)
Origin of wetted parts	International	<ul style="list-style-type: none"> ■ EU ■ CH ■ USA
Type of mounting	Direct mounting	Capillary
System fill fluid	KN 92	KN 7
Surface roughness	Ra ≤ 0.76 µm	Ra ≤ 0.38 µm (only with 1.4435)
Permissible temperature range		-
Medium Ambient CIP, SIP Storage	10 ... 100 °C (50 ... 212 °F) 10 ... 40 °C (50 ... 104 °F) ≤ 130 °C (≤ 266 °F) 10 ... 60 °C (50 ... 140 °F)	

Example: Diaphragm seal model 990.30 with mounted pressure gauge and retainer flange



Possible measuring instruments for a diaphragm seal system

Model			Ex version	Data sheet
232.50.100	Bourdon tube pressure gauge		Option: Ignition protection type "c", constructive safety	PM 02.02
232.30.100	Bourdon tube pressure gauge, safety version		Option: Ignition protection type "c", constructive safety	PM 02.04
PGT23.100	Bourdon tube pressure gauge with electrical output signal		Option: Intrinsically safe Ex i	PV 12.04
S-20	Pressure sensor for superior industrial applications		-	PE 81.61
IS-3	Pressure transmitter intrinsically safe Ex i		Standard: Intrinsically safe Ex i	PE 81.58
PSD-4	Electronic pressure switch with display		-	PE 81.86
UPT-20	Process transmitter		Option: Intrinsically safe Ex i	PE 86.05
CPG1500	Precision digital pressure gauge		Standard: Intrinsically safe Ex i	CT 10.51

Material combinations

Maximum permissible process pressure	Upper body of diaphragm seal	Wetted parts (diaphragm)
≤ PN 600	Stainless steel 1.4435 (316L)	Stainless steel 1.4435 (316L), standard version
> PN 600	Stainless steel 1.4542 (316L)	Stainless steel 1.4571 (316Ti)

Process connection ≤ PN 600

(Example with mounted Bourdon tube pressure gauge model 233.30.100)

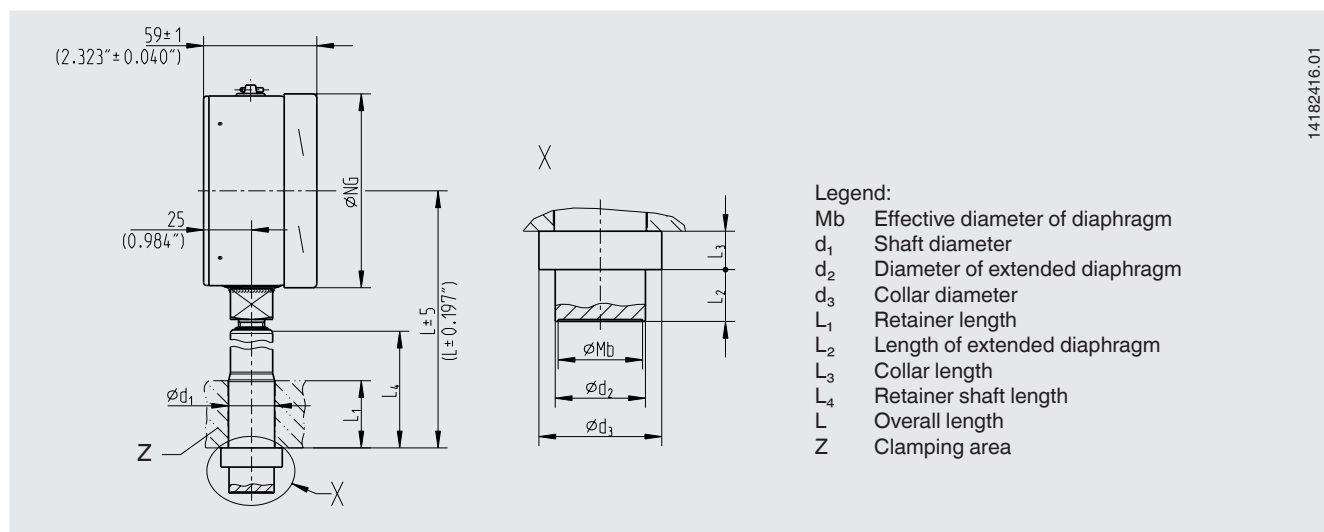

14182416.01

Dimensions in mm (inch)								
Mb	d ₁	d ₂	d ₃	L ₁	L ₂	L ₃	L ₄	L
22 (0.866)	24 / 31 (0.945 / 1.22)	23.8 / 26 (0.937 / 1.024)	34.9 / 37.5 (1.374 / 1.476)	30 (1.18)	13.5 / 10 (0.531 / 0.394)	10 / 10 (0.394 / 0.394)	77 (3.031)	150 (5.905)
				50 (1.968)			97 (3.819)	170 (6.693)
				80 (3.15)			127 (5)	200 (7.874)
				100 (3.937)			147 (5.787)	220 (8.661)

Dimensions in mm (inch)								
Mb	d ₁	d ₂	d ₃	L ₁	L ₂	L ₃	L ₄	L
22 (0.866)	22 (0.866)	23.8 (0.937)	34.9 (1.374)	30 (1.18)	13.5 (0.531)	10 (0.394)	77 (3.031)	150 (5.905)
				50 (1.968)			97 (3.819)	170 (6.693)
				80 (3.15)			127 (5)	200 (7.874)
				100 (3.937)			147 (5.787)	220 (8.661)

Other dimensions on request

Process connection ≤ PN 1600 and ≤ PN 2500
 (Example with mounted Bourdon tube pressure gauge model 233.30.100)

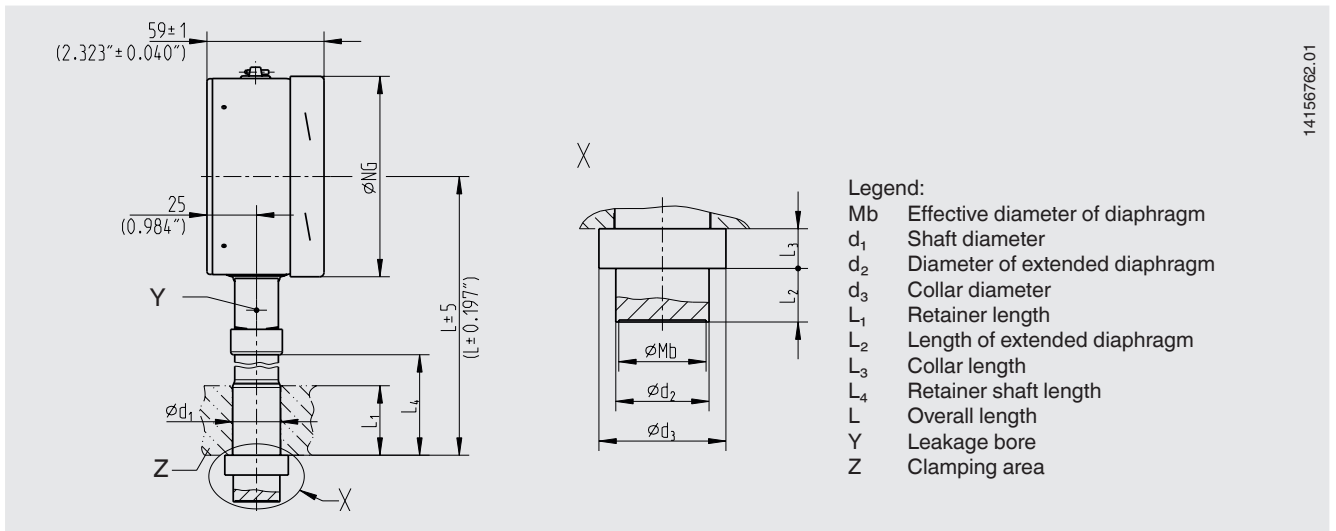

14156762.01

Process connection ≤ PN 1600



Dimensions in mm (inch)									
Mb	d ₁	d ₂	d ₃	L ₁	L ₂	L ₃	L ₄	L	
22 (0.866)	24 / 31 (0.945 / 1.22)	23.8 / 26 (0.937 / 1.024)	34.9 / 37.5 (1.374 / 1.476)	30 (1.18)	13.5 / 10 (0.531 / 0.394)	10 / 10 (0.394 / 0.394)	60.5 (2.382)	150 (5.905)	
				50 (1.968)				80.5 (3.169)	170 (6.693)
				80 (3.15)				110.5 (4.35)	200 (7.874)
				100 (3.937)				130.5 (5.138)	220 (8.661)

Process connection ≤ PN 2500

Dimensions in mm (inch)									
Mb	d ₁	d ₂	d ₃	L ₁	L ₂	L ₃	L ₄	L	
22 (0.866)	22 (0.866)	23.5 (0.925)	32 (1.26)	30 (1.18)	13 (0.512)	1 (0.394)	60.5 (2.382)	150 (5.905)	
				50 (1.968)				80.5 (3.169)	170 (6.693)
				80 (3.15)				110.5 (4.35)	200 (7.874)
				100 (3.937)				130.5 (5.138)	220 (8.661)

Other dimensions on request

Approvals

Logo	Description	Country
	EU declaration of conformity <ul style="list-style-type: none"> ■ EMC directive EN 61326 emission (group 1, class B) and immunity (industrial application) ■ Pressure equipment directive 	European Union
	3-A Sanitary Standard This instrument is 3-A marked, based on a third party verification for conformance to the 3-A standard. Only in combination with COP (cleaning out of place).	USA
	EAC (option) Pressure equipment directive	Eurasian Economic Community
-	CRN Safety (e.g. electr. safety, overpressure, ...)	Canada
-	MTSCHS (option) Permission for commissioning	Kazakhstan

Certificates (option)

- 2.2 test report per EN 10204 (e.g. state-of-the-art manufacturing, material proof, indication accuracy for diaphragm seal systems)
- 3.1 inspection certificate per EN 10204 (e.g. material proof for wetted metallic parts, indication accuracy for diaphragm seal systems)

Further approvals and certificates on request.

Ordering information

Diaphragm seal:

Diaphragm seal model / Process connection (nominal width, nominal pressure rating, shaft diameter, shaft length, diameter of sealing collar, length of sealing collar, diameter of extended diaphragm, length of extended diaphragm) / Materials (extended diaphragm, diaphragm) / Level of cleanliness of wetted parts / Origin of wetted parts / Connection to the measuring instrument / Certificates / Retainer parts (flange)

Diaphragm seal system:

Diaphragm seal model / Pressure measuring instrument model (per data sheet) / Mounting (direct mounting, cooling element, capillary) / Materials (upper body, diaphragm) / Min. and max. process temperature / Min. and max. ambient temperature / System fill fluid / Certificates / Height difference / Level of cleanliness of wetted parts / Origin of wetted parts / Instrument mounting bracket / Process connection (nominal width, nominal pressure) / Retainer parts (flange)

© 09/2017 WIKA Alexander Wiegand SE & Co. KG, all rights reserved.
The specifications given in this document represent the state of engineering at the time of publishing.
We reserve the right to make modifications to the specifications and materials.

