

Diaphragm seal with sterile connection

For sanitary applications

Model 990.60, NEUMO BioControl® connection

WIKA data sheet DS 99.55



for further approvals
see page 3

Applications

- Pharmaceutical and biotechnology industries
- Production of active ingredients

Special features

- Dead space free
- Hygienic design
- Materials and surface finish qualities in accordance with pharmaceutical industry directives and standards
- 3-A compliant

Description

Diaphragm seals are used to protect the pressure measuring instrument from aggressive, adhesive, crystallising, corrosive, highly viscous, environmentally hazardous or toxic media. A diaphragm made of the appropriate material provides for the separation from the medium to be measured. Thus even the most difficult measuring requirements can be met by combining measuring instruments with diaphragm seals.

A fluid inside the system, which can be chosen to suit the particular application, hydraulically transmits the pressure to the measuring instrument.

Almost limitless application possibilities exist due to the large number of available variants, such as diaphragm seal designs or materials. The type of process connection (flange, threaded and sterile connection) and the basic method of manufacture are important design differentiation criteria.

For further technical information on diaphragm seals and diaphragm seal systems see IN 00.06 „Application, operating principle, designs“.



Diaphragm seal with sterile connection, model 990.60

The model 990.60 diaphragm seal with NEUMO BioControl® connection is particularly suited for use in sterile processes and is adapted to the process via the NEUMO BioControl® housing. This enables a hygienic integration of measuring instruments into pipelines or, by means of block flanges, into tanks or fermenters.

The diaphragm seal systems can withstand the cleaning vapour temperatures occurring in the SIP processes and thus ensure a sterile connection between the medium to be measured and the diaphragm seal.

Assembly of the diaphragm seal and measuring instrument is made via a direct assembly as standard or optionally via a cooling element or a flexible capillary.

For the material selection WIKA offers a variety of solutions, in which the upper body and the diaphragm are made of identical materials. Stainless steel 316L (1.4435) is used as standard material, other special materials are available on request.

Measuring systems with model 990.60 WIKA diaphragm seals are successfully used in the life science industry, in pharmaceutical and biotechnology applications.

Standard version

Type of process connection

NEUMO BioControl® connection for installation into model 910.60 NEUMO BioControl® system, see data sheet AC 09.14

- Size 25 (mounting diameter 30.5 mm)
- Size 50 (mounting diameter 50.0 mm)
- Size 65 (mounting diameter 68.0 mm)
- Size 80 (mounting diameter 87.5 mm)

Nominal pressure

PN 16 for size 50 ... 80

PN 25 for size 25

Measuring ranges

0 ... 0.25 bar to 0 ... 16 bar for size 50 ... 80

0 ... 25 bar for size 25

(also vacuum and +/- measuring ranges)

Material of upper body

Stainless steel 1.4435 (316 L)

Material of wetted parts

Diaphragm: Stainless steel 1.4435 (316L)

Surface roughness of wetted parts

$Ra \leq 0.76 \mu\text{m}$ per ASME BPE SF3 (except for weld seam)

Level of cleanliness of wetted parts

Oil and grease free per ASTM G93-03 level E (WIKA standard) and ISO 15001 ($<550 \text{ mg/m}^2$)

Connection to the measuring instrument

Axial weld-in connection

Options

Process connection

- Surface roughness of wetted parts
 $Ra \leq 0.38 \mu\text{m}$ per ASME BPE SF4, only with electropolished surface (except for weld seam)
- Sealing from EPDM or FEP with FPM core
- Connection to the measuring instrument
G 1/2, G 1/4, 1/2 NPT or 1/4 NPT (female)
- Origin of wetted parts (EU, CH, USA)
- Marking of the diaphragm seal with 3-A standard

NEUMO BioControl® connection and NEUMO BioControl® system are registered trademarks of the NEUMO-Ehrenberg Group.

Installation example

Diaphragm seal, sterile connection, model 990.60 with directly assembled pressure gauge on a NEUMO BioControl® system

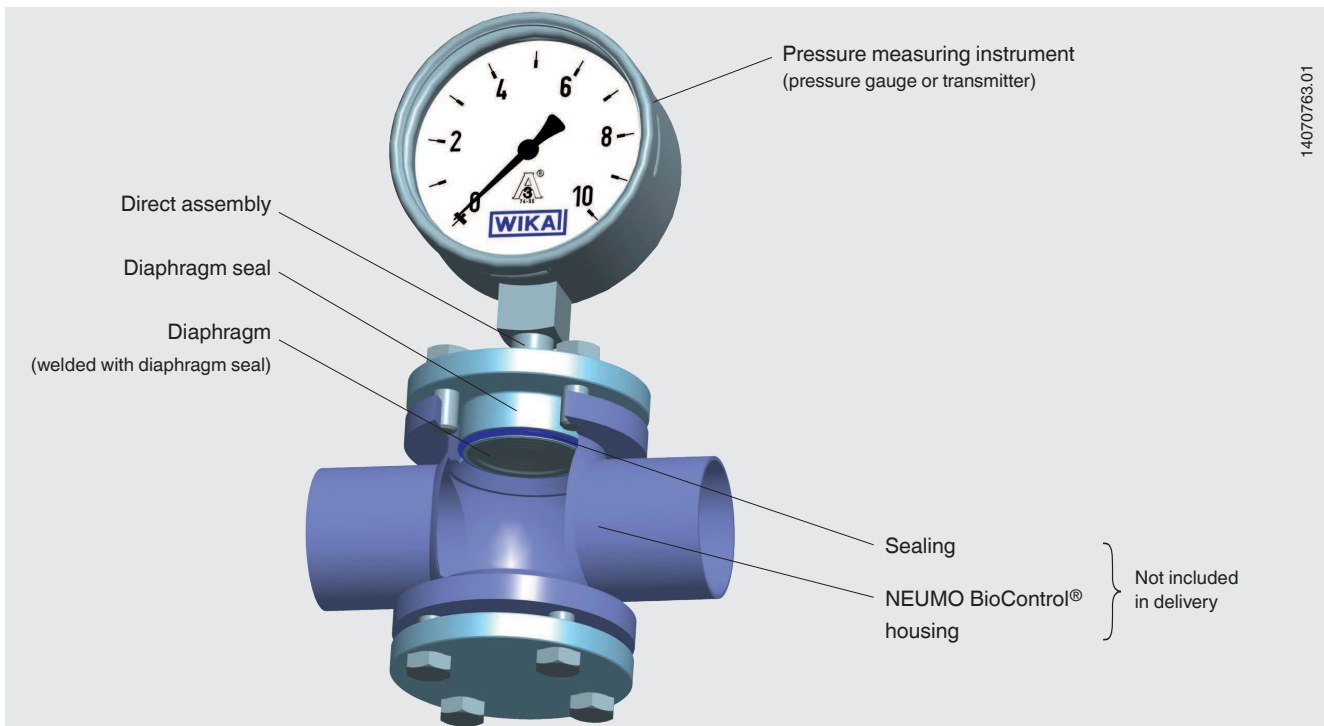

Additional information for diaphragm seal systems

See Technical information IN 00.06 "Diaphragm seals - Diaphragm seal systems, application, operating principle, designs"

- Pressure measuring instrument model
- Connection to the measuring instrument: Direct assembly (calibrated in vertical mounting position, process connection facing downwards)
- Process temperature
- Ambient temperature
- System fill fluid
 - Recommendation for pharmaceutical and cosmetics applications: Medicinal white mineral oil KN 92 (FDA 21 CFR 172.878, 21 CFR 178.3620(a); USP, EP)

Options for diaphragm seal systems

- Connection to the measuring instrument via cooling element or capillary
- Vacuum service (suitable for vacuum operation)
- Higher level of cleanliness of wetted parts
 - Oil and grease free per ASTM G93-03 level D and ISO 15001 (< 220 mg/m²)
 - Oil and grease free per ASTM G93-03 level C and ISO 15001 (< 66 mg/m²)
- Height difference between measuring point and pressure measuring instrument with capillary in metre increments (max. 7 m with silicone oils/edible oils)
- Mounting bracket (required for connection to the measuring instrument via capillary, model 910.16, data sheet AC 09.07)
 - Form H per DIN 16281, 100 mm, aluminium, black
 - Form H per DIN 16281, 100 mm, stainless steel
 - Bracket for pipe mounting, for pipe Ø 20 ... 80 mm, steel

Materials

Upper body	Wetted part Diaphragm
Standard	
Stainless steel 1.4435 (316L)	Stainless steel 1.4435 (316L)
Option	
Stainless steel 1.4435 (316L), electropolished	Stainless steel 1.4435 (316L), electropolished ¹⁾
Stainless steel 1.4539 (904L)	Stainless steel 1.4539 (904L)
Hastelloy C276 (2.4819)	Hastelloy C276 (2.4819)

1) Only in connection with a surface roughness of Ra ≤ 0.38 µm for the wetted parts

Further material combinations on request

Approvals

- **EAC**, Einfuhrzertifikat, Zollunion Russland/Belarus/Kasachstan
- **3-A (option)**, food, USA
- **CRN**, safety (e.g. electr. safety, overpressure, ...), Canada

Certificates (option)

- 2.2 test report per EN 10204 (e.g. state-of-the-art manufacturing, material proof, indication accuracy for diaphragm seal systems)
- 3.1 inspection certificate per EN 10204 (e.g. material proof for wetted metallic parts, indication accuracy for diaphragm seal systems)
- FDA conformity of the system fill fluid
- 3-A conformity of the diaphragm seal, based on a third party verification
- Manufacturer's declaration regarding EU regulation 1935/2004 EC
- Others on request

Approvals and certificates, see website

Dimensions in mm

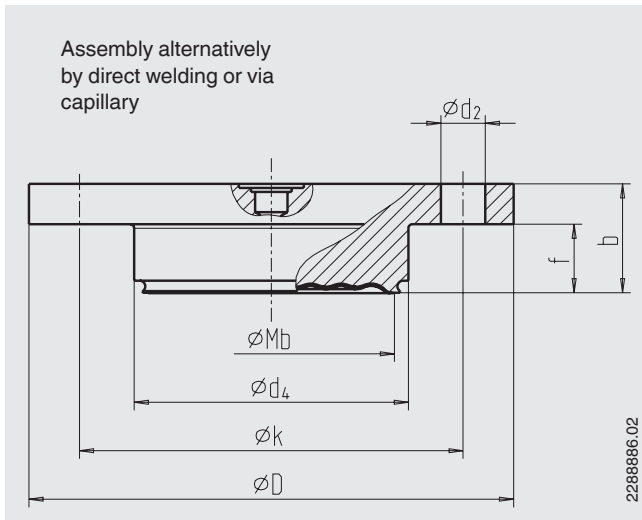

BioControl® connection	Dimensions in mm							Weight in kg
	Mb	d ₂	d ₄	D	f	b	k	
Size 25	22	4 x Ø 7	30.5	64	11	20	50	0.27
Size 50	40	4 x Ø 9	50	90	17	27	70	0.65
Size 65	59	4 x Ø 11	68	120	17	27	95	1.30
Size 80	72	4 x Ø 11	87.5	140	25	37	115	2.65

Mb = effective diameter of diaphragm

Ordering information

Diaphragm seal:

Diaphragm seal model / Process connection / Material (upper body, diaphragm) / Surface roughness of wetted parts / Sealing / Connection to the measuring instrument / Level of cleanliness of wetted parts / Origin of wetted parts / Certificates

Diaphragm seal system:

Diaphragm seal model / Process connection / Material (upper body, diaphragm) / Surface roughness of wetted parts / Sealing / Pressure measuring instrument model (per data sheet) / Assembly (direct assembly, cooling element, capillary) / min. and max. process temperature / min. and max. ambient temperature / Vacuum service / System fill fluid / Certificates / Height difference / Level of cleanliness of wetted parts / Origin of wetted parts / Mounting bracket

© 03/2008 WIKA Alexander Wiegand SE & Co. KG, all rights reserved.
The specifications given in this document represent the state of engineering at the time of publishing.
We reserve the right to make modifications to the specifications and materials.



WIKAL Alexander Wiegand SE & Co. KG
Alexander-Wiegand-Straße 30
63911 Klingenberg/Germany
Tel. +49 9372 132-0
Fax +49 9372 132-406
info@wika.de
www.wika.de