

Bourdon tube pressure gauge Test gauge series, class 0.6 Models 332.50, 333.50

WIKA data sheet PM 03.06



for further approvals
see page 3

Applications

- With liquid-filled case for applications with high dynamic pressure loads or vibrations ¹⁾
- For gaseous and liquid aggressive media that are not highly viscous or crystallising, also in aggressive ambience
- Precision measurement in laboratories
- High-accuracy pressure measurement
- Testing of industrial type pressure gauges

Special features

- All stainless steel construction
- Knife edge pointer for optimal accuracy of reading
- Wear-resistant precision movement from stainless steel
- Scale ranges up to 0 ... 1,600 bar

Description

Design

EN 837-1

Nominal size in mm

160

Accuracy class

0.6

Scale ranges

0 ... 0.6 to 0 ... 1,600 bar
or all other equivalent vacuum or combined pressure and vacuum ranges

Adjustment medium

≤ 25 bar: Gas
> 25 bar: Liquid



Test gauge series, stainless steel, model 332.50

Pressure limitation

Steady: Full scale value
Fluctuating: 0.9 x full scale value
Short time: 1.3 x full scale value

Permissible temperature

Ambient: -40 ... +60 °C without liquid filling
-20 ... +60 °C with glycerine filling ¹⁾
Medium: +200 °C maximum without liquid filling
+100 °C maximum with liquid filling ¹⁾

Temperature effect

When the temperature of the measuring system deviates from the reference temperature (+20 °C): max. ±0.4 %/10 K of full scale value

Ingress protection

IP65 per IEC/EN 60529

¹⁾ Model 333.50

Standard version

Process connection

Stainless steel 316L,
lower mount (LM) or lower back mount (LBM)
G ½ B (male), 22 mm flats

Pressure element

Stainless steel 316L,
< 100 bar: C-type
≥ 100 bar: Helical type
≥ 1,000 bar: Ni-Fe-alloy, helical type

Movement

Stainless steel

Dial

Aluminium, white, black lettering

Pointer

Knife edge pointer, aluminium, black

Case

Stainless steel, with pressure relief in case back, scale ranges ≤ 0 ... 10 bar with compensating valve to vent case

Window

Laminated safety glass

Bezel ring

Cam ring (bayonet type), stainless steel

Filling liquid (for model 333.50)

Glycerine

Options

- Other process connection
- Sealings (model 910.17, see data sheet AC 09.08)
- Surface or panel mounting flange, stainless steel
- Triangular bezel, polished stainless steel, with clamp
- Higher indication accuracy (for gauges without liquid filling): Class 0.25 per EN 837 or grade 3A per ASME B 40.1 for scale ranges ≤ 400 bar
- Mirror band scale
- Zero point adjustable from outside (adjustable dial, only without case filling)
- Adjustment medium gas from 25 bar
- Transport case

EU conformity

Pressure equipment directive

PS > 200 bar, module A, pressure accessory

Approvals

- **EAC**, import certificate, customs union Russia/Belarus/Kazakhstan
- **GOST**, metrology/measurement technology, Russia
- **CRN**, safety (e.g. electr. safety, overpressure, ...), Canada

Certificates (option)

- 2.2 test report per EN 10204 (e.g. state-of-the-art manufacturing, material proof, indication accuracy)
- 3.1 inspection certificate per EN 10204 (e.g. material proof wetted parts metal component, indication accuracy)
- DKD/DAkkS certified accuracy

Approvals and certificates, see website

Dimensions in mm

Standard version

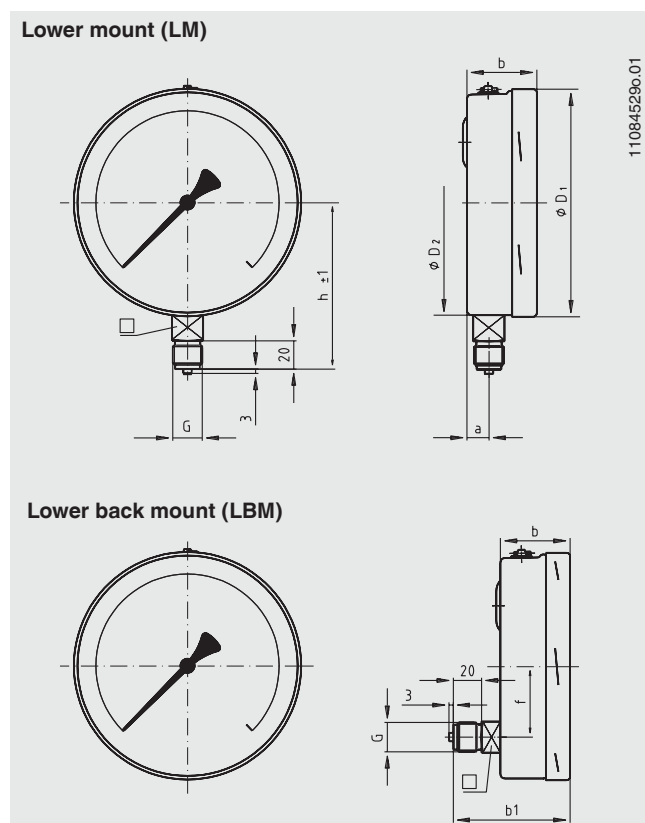

NS	Dimensions in mm									Weight in kg
	a	b	b1	D ₁	D ₂	f	G	h ±1	SW	
160	15.5 ¹⁾	49.5 ¹⁾	83 ¹⁾	161	159	50	G ½ B	118	22	1.10

Process connection per EN 837-1 / 7.3
 1) Plus 16 mm with scale ranges ≤ 4 bar and ≥ 100 bar

Ordering information

Model / Nominal size / Scale range / Connection size / Connection location / Options

© 03/2008 WIKA Alexander Wiegand SE & Co. KG, all rights reserved.
 The specifications given in this document represent the state of engineering at the time of publishing.
 We reserve the right to make modifications to the specifications and materials.



WIKAI Alexander Wiegand SE & Co. KG
 Alexander-Wiegand-Straße 30
 63911 Klingenberg/Germany
 Tel. +49 9372 132-0
 Fax +49 9372 132-406
 info@wika.de
 www.wika.de