

HYDRA-Sensors

Ultra High Purity Pressure Transducer

Model HS

WIKA Data Sheet SP 99.21

Applications

- Semiconductor industry
- UHP-liquid chemicals distribution

Special features

- Patented double diaphragm
- Perfluoroalkoxy (PFA) wetted parts
- Transducer is 360° rotatable even after installation
- Ingress protection IP 65 or IP 67
- Optional: attachable indicator see data sheet PE 82.11

Description

HYDRA-line

Our pressure measuring instruments of the HYDRA-line product family have been developed in co-operation with well-known customers in the semiconductor industry. The complete product concept has been adapted to the special requirements of the process equipment and UHP chemicals distribution system sectors.

The HYDRA-Sensor pressure transducer offers high accuracy and reliability, ultra clean wetted parts and surfaces. Furthermore, the production of all wetted parts, cleaning assembly, calibration and packaging takes place in a class 100 cleanroom.

Double safety

The patented HYDRA double diaphragm system enables a safe and reliable separation of the pressure sensor from the process medium. Simultaneously diffusing process media such as HF or HCl vapours are given off to the environment to avoid any falsification of the measuring result or the destruction of the sensor element.

The offer for sale of this product does not infer or imply chemical compatibility with specific applications. Some applications of this product can and will cause diffusion of chemicals through the diaphragm materials.



HYDRA-line Model HS, transducer 4 ... 20 mA, 2-wire system and in-line 1/2" flare process connection



HYDRA-line Model HS, transducer 4 ... 20 mA, 2-wire system and dead-end 1/2" flare process connection

Specifications

Model HS, HYDRA-Sensor

Pressure ranges	bar	0 ... 2.5	0 ... 4	0 ... 6
	psi	0 ... 30	0 ... 60	0 ... 100
	kPa	0 ... 250	0 ... 400	0 ... 600
Overpressure safety of sensor	bar	40 ¹⁾		
Process connection		in-line 3/8" flare, 1/2" flare, 3/4" flare, 1" flare, 1 1/4" flare dead-end 1/4" flare, 3/8" flare, 1/2" flare dead-end 1/4" NPT female		
Pressure measurement device		Pressure transducer according to data sheet PE 81.01		
Accuracy	% of span	≤ 0.5		
Material				
■ Wetted parts		PFA or TFM (modified PTFE)		
■ Other non-wetted parts		PVDF, EPDM, FPM/FKM		
■ Transducer		Stainless steel		
System fill fluid		KN 75 50/50 mix semiconductor grade IPA (Isopropyl Alcohol/DI Water) precision filled and not field refillable		
Permissible temperature range				
■ Process	°C	+5 ... +60 (+41 ... +140 °F)		
■ Ambient	°C	+5 ... +60 (+41 ... +140 °F)		
■ Storage	°C	-20 ... +60 (-4 ... +140 °F)		
Temperature-coefficients	% of span/10K	≤ 0.25 (from 5 °C to 60 °C)		
Electrical connection		4-pin L-plug DIN EN 175301-803 A (IP 65) or 5 m flying lead (IP 67)		
Ingress protection per IEC 60 529 / EN 60 529		IP 65 or IP 67		

1) Limited by maximum pressure rating of the process connection see diagram below

Considerations for use:

This transmitter can be rotated a full 360° by hand. No tools required.

The transmitter can not be removed or the central PVDF nut loosened from the housing as this may cause the fill fluid to leak destroying the measuring unit.

Pressure-temperature rating

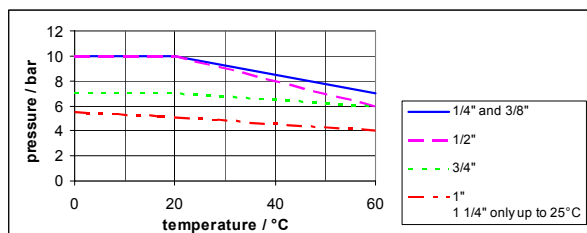

Dimensions in mm

HYDRA-line, Model HS, in-line flare process connection

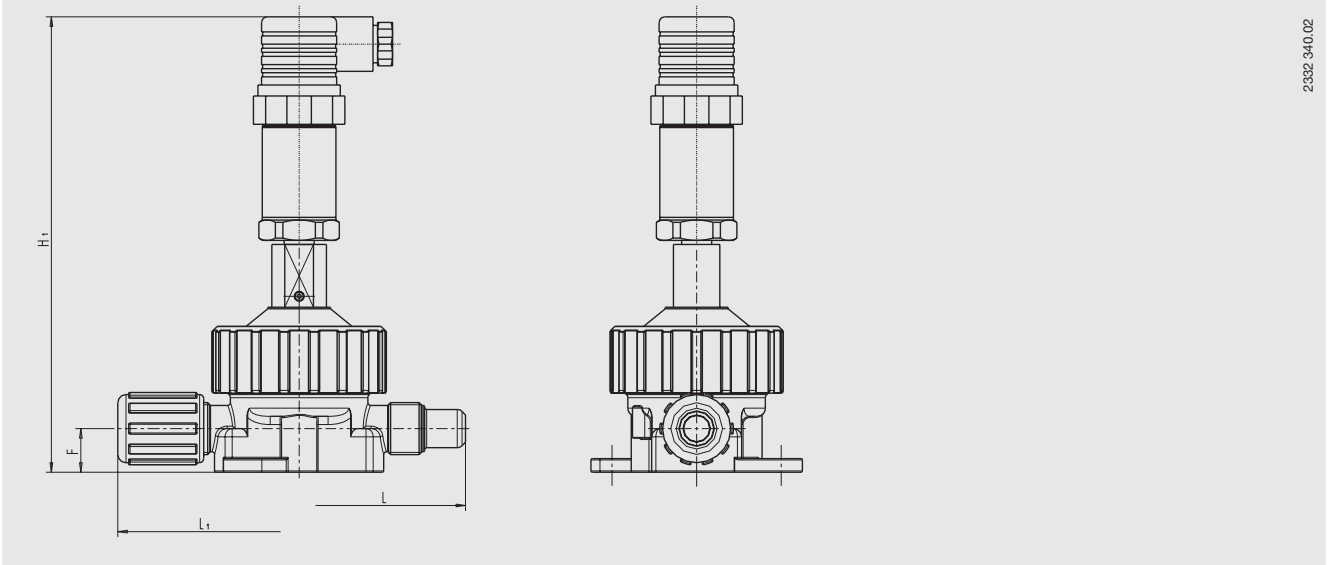

2332 340.02

Process connection	Dimensions in mm						
	H	L	L ₁	F	B ₁	B ₂	Ød ₂
In-line 3/8" flare	167	118	127	16	40	62	5.5
In-line 1/2" flare	167	122	133	16	40	62	5.5
In-line 3/4" flare	172	122	133	19	40	62	5.5
In-line 1" flare	197	165	179	25	56	78	6.5
In-line 1 1/4" flare	197	224	238	25	56	78	6.5

HYDRA-line, Model HS, dead-end process connection

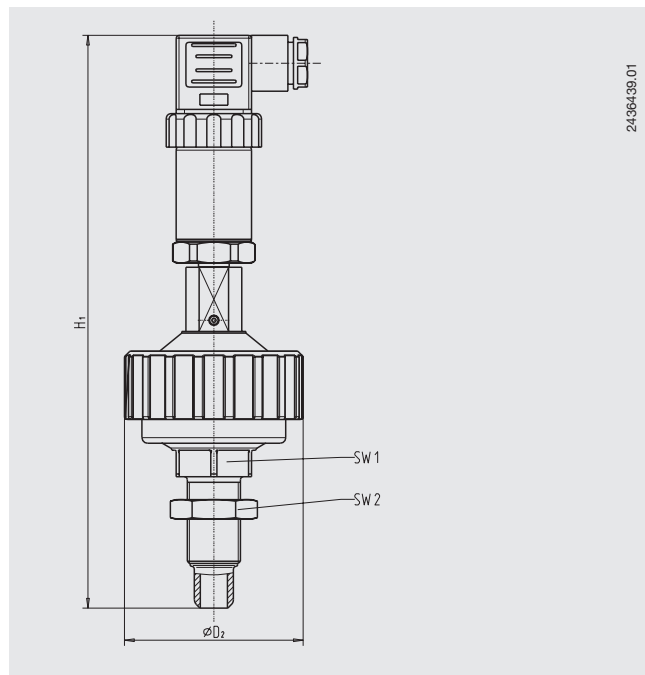

2436439.01

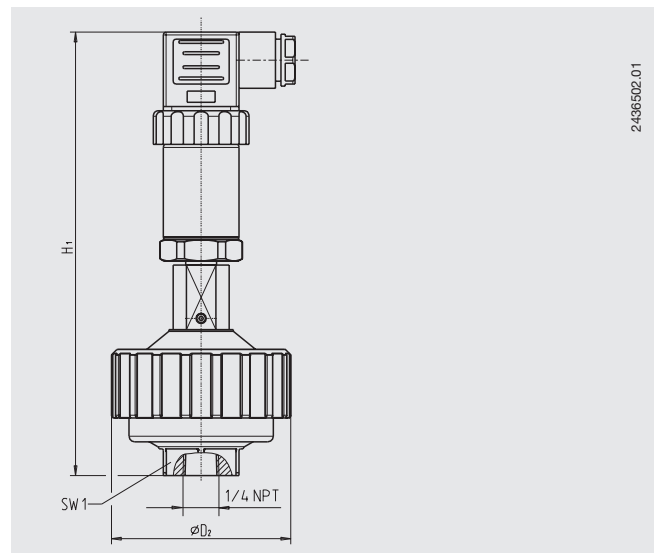

2436502.01

Process connection	Dimensions in mm			
	H ₁	SW1	SW2	Ød ₂
Dead-end 1/4" flare	205 ± 2	27	11/16"	64
Dead-end 3/8" flare	205 ± 2	27	15/16"	64
Dead-end 1/2" flare	208 ± 2	27	17/16"	64
Dead-end 1/4 NPT female	161 ± 2	27	-	64

Ordering information code for pressure system HYDRA-line, Model HS

Field No.	Code	Features
		Unit
	B	bar
	P	psi
	A	kPa
1	<input type="checkbox"/>	? other <i>please state as additional text</i>
		Range
	BF	0 bar ... 2.5 bar 0 psi ... 30 psi 0 kPa ... 250 kPa
	BG	0 bar ... 4 bar 0 psi ... 60 psi 0 kPa ... 400 kPa
	BH	0 bar ... 6 bar 0 psi ... 100 psi 0 kPa ... 600 kPa
2	<input type="checkbox"/>	?? other <i>please state as additional text</i>
		Electrical connection
	A	4-pin L-plug DIN EN 175301-803 A, IP 65
3	<input type="checkbox"/>	F 5 m flying lead, IP 67
		Digital display
	Z	without
4	<input type="checkbox"/>	B LCD, 4-digit, see data sheet PE 82.11 <i>only available with electrical connection L-plug</i>
		Process connection
	06	in-line 3/8 " flare
	08	in-line 1/2 " flare
	12	in-line 3/4 " flare
	16	in-line 1 " flare
	20	in-line 1 1/4 " flare
	38	dead-end 1/4 " flare
	40	dead-end 3/8 " flare
	42	dead-end 1/2 " flare
5	<input type="checkbox"/>	50 dead-end 1/4 NPT female
		Flare nut
	77	PFA <i>only for flare connections, not for NPT</i>
	75	PVDF <i>only for flare connections, not for NPT</i>
6	<input type="checkbox"/>	ZZ without <i>only with NPT connections</i>
		System fill fluid
7	<input type="checkbox"/>	L1 KN 75 iso-propyl-alcohol (IPA) / DI-water 50:50
		Additional order info
	YES	NO
8	<input type="checkbox"/>	1 Z additional text <i>Please state as clearly understandable text!</i>

Order code:

	1	2	3	4	5	6	7	8	
HS	-	<input type="text"/>	<input type="text"/>	<input type="text"/>	<input type="text"/>	<input type="text"/>	L1	-	<input type="text"/>

Optional designs on request

Additional text:

Modifications may take place and materials specified may be replaced by others without prior notice. Specifications and dimensions given in this leaflet represent the state of engineering at the time of printing.



WIKAL Alexander Wiegand GmbH & Co. KG
 Alexander-Wiegand-Straße 30
 63911 Klingenberg/Germany
 Phone (+49) 93 72/132-0
 Fax (+49) 93 72/132-406
 E-Mail info@wika.de
 www.wika.de