

Measuring insert for resistance thermometer Model TR11-A, tubular design

WIKA data sheet TE 60.13



for further approvals
see page 2

Applications

- Replacement measuring insert for servicing
- For all industrial and laboratory applications

Special features

- Application ranges from -50 ... +250 °C (-58 ... +482 °F)
- Tubular design
- Spring-loaded design
- Explosion-protected versions



Measuring insert for resistance thermometer, model TR11-A

Description

The measuring inserts per DIN 43735 for resistance thermometers described here are designed for mounting in a protective fitting. Operation without thermowell is only recommended in certain applications. The measuring insert has been manufactured from a pipe closed on one side. The sensor is located in the tip of the measuring insert. The measuring inserts are delivered with pressure springs to ensure that the measuring inserts are pressed down to the thermowell bottom.

Apart from the DIN versions, customer-specific versions are available, for example:

- other measuring insert lengths (also intermediate lengths)
- without terminal block
- with transmitter

Type and number of sensors, accuracy and connection method can each be selected to suit the respective application.

The range of applications is completed by designs without terminal block for direct transmitter installation. Optionally, analogue or digital transmitters from the WIKA range can be installed.

Explosion protection







The classification/suitability of the instrument (permissible power P_{max} as well as the permissible ambient temperature) for the respective category can be seen on the EC-type examination certificate, the Ex certificate or in the operating instructions.

Attention:

Depending on the version, the measuring insert can be used in “intrinsically safe Ex i” or “non-incendive Ex n” ignition protection types when built into a model TR11-C resistance thermometer. With the correspondingly suitable protective fitting, operation in dust Ex hazardous areas is possible.

The use of a model TR11-A measuring insert is not permitted in hazardous areas without a suitable protective fitting.

Approvals (explosion protection, further approvals)

Logo	Description	Country
	EU declaration of conformity EMC directive ¹⁾ EN 61326 emission (group 1, class B) and interference immunity (industrial application)	European Union
	ATEX directive (option) Hazardous areas - Ex i Zone 1 gas [II 2G Ex ia IIC T3 ... T6 Gb] - Ex n Zone 2 gas [II 3G Ex nA IIC T1 ... T6 Gc X]	
	IECEx (option) (in conjunction with ATEX) Hazardous areas - Ex i Zone 1 gas [Ex ia IIC T3 ... T6 Gb]	International
	EAC (option) Hazardous areas - Ex i Zone 1 gas [1 Ex ib IIC T3/T4/T5/T6] - Ex n Zone 2 gas [Ex nA IIC T6 ... T1]	Eurasian Economic Community
	INMETRO (option) Hazardous areas - Ex i Zone 1 gas [Ex ib IIC T3 ... T6 Gb]	Brazil
	KCS - KOSHA (option) Hazardous areas - Ex i Zone 1 gas [Ex ib IIC T4 ... T6]	South Korea
-	PESO (option) Hazardous areas - Ex i Zone 1 gas [Ex ib IIC T3 ... T6 Gb]	India
	GOST Metrology, measurement technology	Russia

1) Only for built-in transmitter

Instruments marked with “ia” may also be used in areas only requiring instruments marked with “ib” or “ic”. If an instrument with “ia” marking has been used in an area with requirements in accordance with “ib” or “ic”, it can no longer be operated in areas with requirements in accordance with “ia” afterwards.

For deliveries to CIS countries and Ukraine, a technical passport is required and generated for each specific order.

Approvals and certificates, see website

Sensor

Measuring element

Pt100 (measuring current: 0.1 ... 1.0 mA) ¹⁾

Connection method	
Single elements	1 x 2-wire 1 x 3-wire 1 x 4-wire 1 x 3-wire (face-sensitive sensor) 1 x 4-wire (face-sensitive sensor)
Dual elements	2 x 2-wire 2 x 3-wire 2 x 4-wire ²⁾

Tolerance value of the measuring insert per EN 60751	
Class	Thin-film
Class B	-50 ... +250 °C
Class A ³⁾	-30 ... +250 °C
Class AA ^{3) 4)}	0 ... +150 °C

- 1) For detailed specifications for Pt100 sensors, see Technical information IN 00.17 at www.wika.com.
- 2) Not with 3 mm diameter
- 3) Not with 2-wire connection method
- 4) Not with face-sensitive sensor

Electrical connection

(Colour code per EN/IEC 60751)

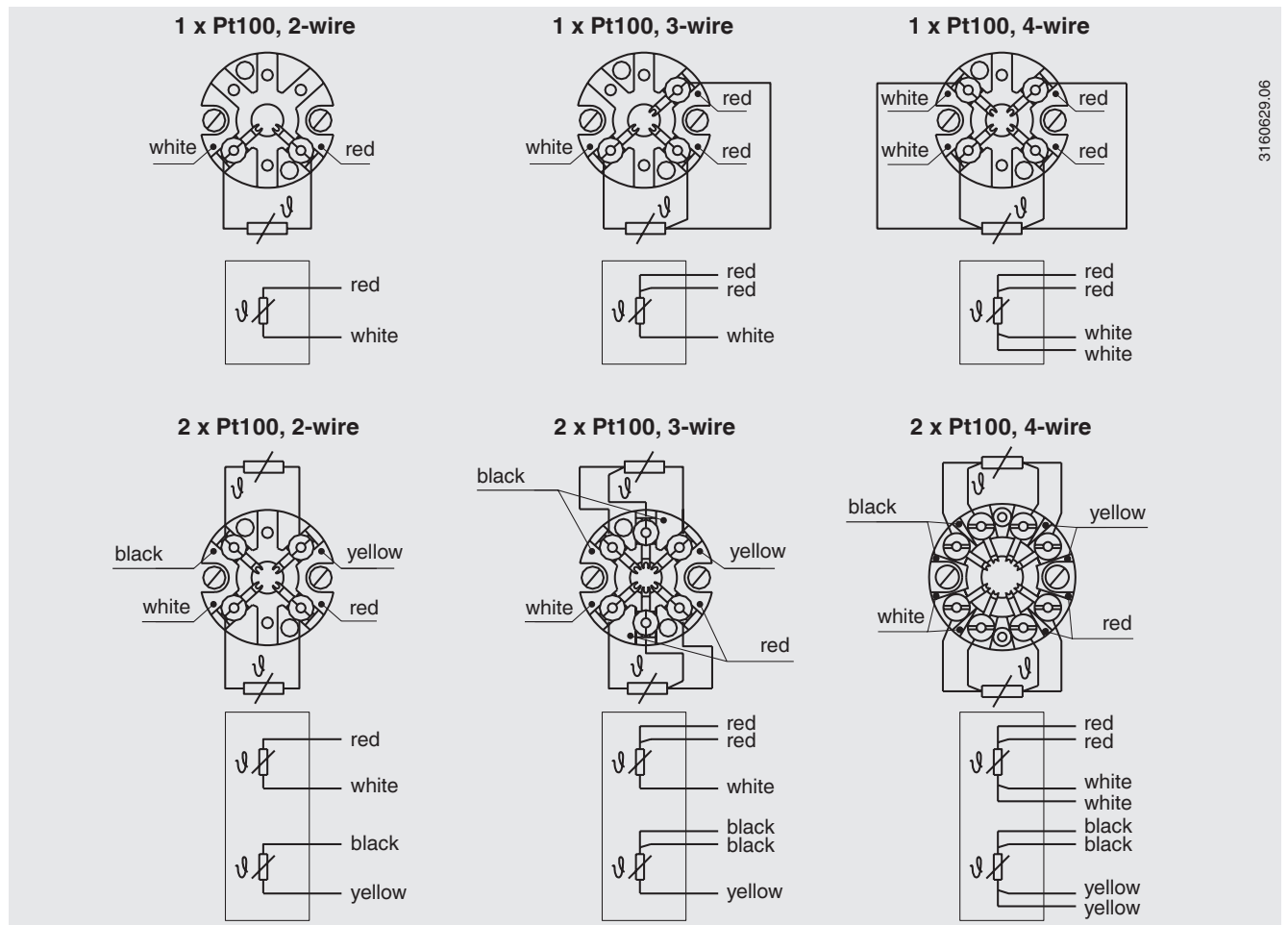

For the electrical connections of built-in temperature transmitters see the corresponding data sheets or operating instructions.

Transmitter (option)

A transmitter can be built upon the measuring insert. In this case, the transmitter replaces the terminal block and is directly attached to the terminal plate of the measuring insert. The temperature transmitter should be protected from temperatures over 85 °C.

Output signal 4 ... 20 mA, HART® protocol, FOUNDATION™ Fieldbus and PROFIBUS® PA			
Transmitter (selectable versions)	Model T15	Model T32	Model T53
Data sheet	TE 15.01	TE 32.04	TE 53.01
Output			
■ 4 ... 20 mA	x	x	
■ HART® protocol		x	
■ FOUNDATION™ Fieldbus and PROFIBUS® PA			x
Connection method			
■ 1 x 2-wire, 3-wire or 4-wire	x	x	x
Measuring current	< 0.2 mA	< 0.3 mA	0.2 mA

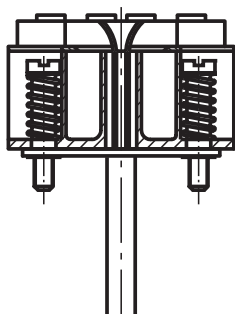

Measuring insert with mounted transmitter
(here: model T32)

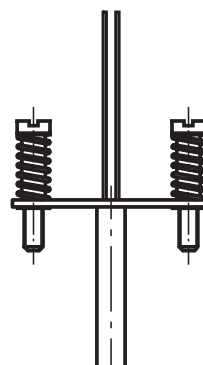

Measuring insert prepared for transmitter mounting

Dimensions in mm

The replaceable measuring insert is made of pipe closed on one side. The terminal blocks are generally built with recessed soldering lugs.

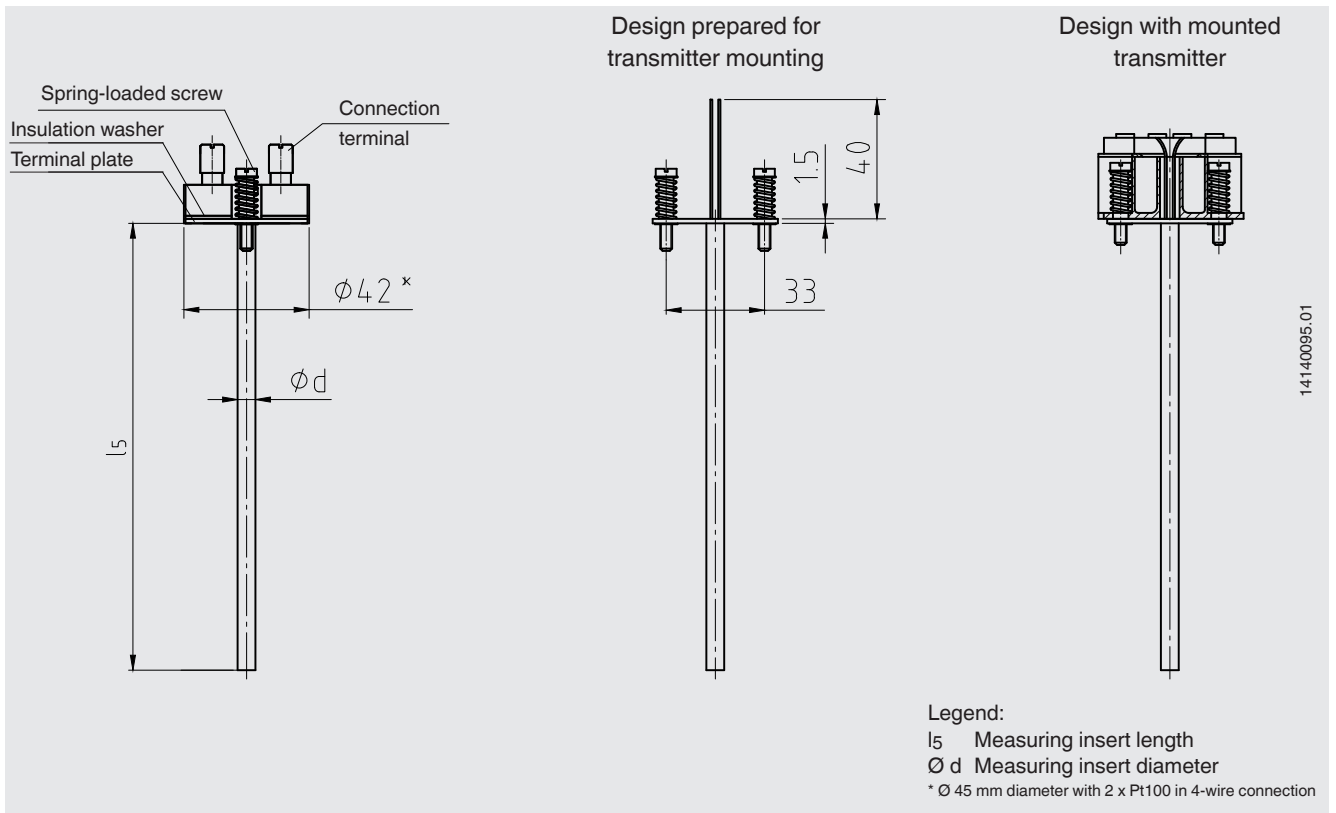

Measuring insert length l_5 in mm		Tolerance in mm
$\varnothing 6, \varnothing 8$	$\varnothing 3$	
75 ... 500	75 ... 250	+2 0

Measuring insert diameter $\varnothing d$ in mm	Index per DIN 43735	Tolerance in mm
3 ¹⁾	31	3 ±0.1
6	61	6 ±0.1
8	81	8 ±0.1

1) Not possible with 2 x Pt100, 4-wire

Only correct measuring insert length and correct measuring insert diameter ensure sufficient heat transfer from thermowell to the measuring insert.

The bore diameter of the thermowell should be a max. 1 mm larger than the measuring insert diameter.

Gaps of more than 0.5 mm between thermowell and the measuring insert will have a negative effect on the heat transfer, and they will result in unfavourable response behaviour of the thermometer.

When fitting the measuring insert into a thermowell, it is very important to determine the correct insertion length (= thermowell length for bottom thicknesses of ≤ 5.5 mm). In order to ensure that the measuring insert is firmly pressed down onto the bottom of the thermowell, the insert must be spring-loaded (spring travel: max 10 mm).

Materials

Material	
Tube material	Stainless steel 1.4571
	Stainless steel 316L

Certificates (option)

Certification type	Measurement accuracy	Material certificate
2.2 test report	x	x
3.1 inspection certificate	x	-
DKD/DAkkS calibration certificate	x	-

The different certifications can be combined with each other.

Operating conditions

Mechanical requirements

Version (per EN 60751)	
Standard	6 g peak-to-peak

The information on the vibration resistance refers to the tip of the measuring insert.

For detailed specifications for vibration resistance of Pt100 sensors, see Technical information IN 00.17 at www.wika.com.

Ambient and storage temperature

-40 ... +80 °C

Ingress protection

IP00 per EN/IEC 60529

The measuring inserts for the model TR11-A are designed for mounting into protective components (connection head + protection tube/thermowell).

These protective components feature connection heads/ cable glands/thermowells/protection tubes which ensure a higher IP protection.

Ordering information

Model / Explosion protection / Ignition protection type / Zone / Sensor / Class accuracy / Application range of the thermometer / Measuring insert length l_5 / Measuring insert diameter $\varnothing d$ / Pipe material / Certificates / Options

© 10/2015 WIKA Alexander Wiegand SE & Co. KG, all rights reserved.
The specifications given in this document represent the state of engineering at the time of publishing.
We reserve the right to make modifications to the specifications and materials.

